

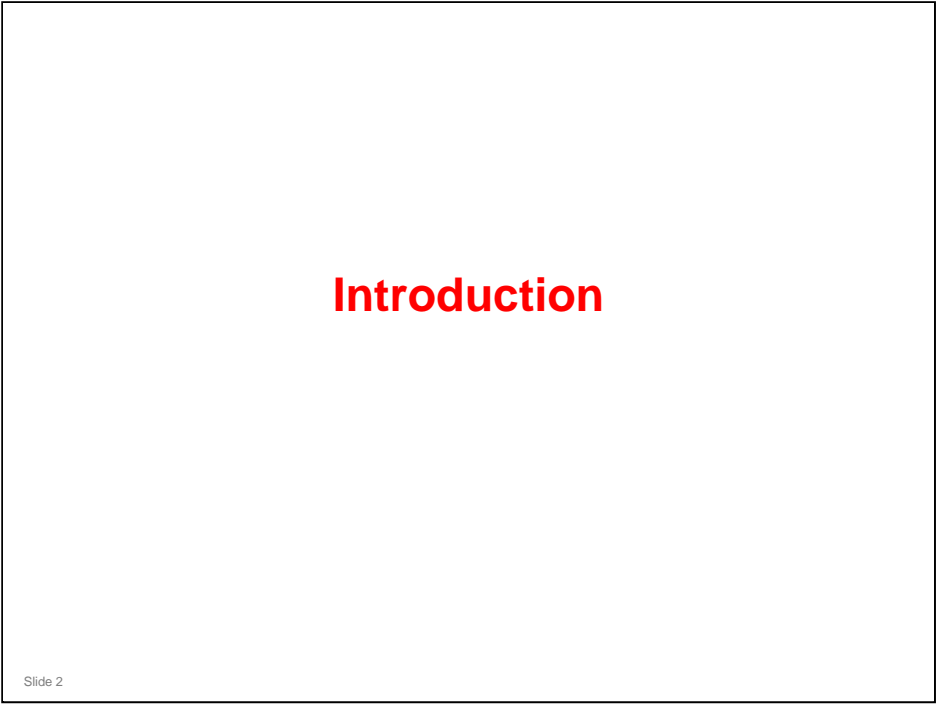

This section explains the differences between this new model and the AT-C2 series.

Date of change	Version History	Description
09-12-2009	1.0.1	Slide 8 modified Slide 9 deleted After slide 12 (old number 13) - two new slides added



No additional notes

How Many Models?

- ❑ **Two models**
 - ◆ AT-C2.5c (D086): 30 cpm
 - ◆ AT-C2.5d (D087): 35 cpm
- ❑ **Both models are 2 cpm faster than AT-C2**
- ❑ **All models have the following equipment built-in:**
 - ◆ Printer/scanner unit.
 - ◆ USB host
 - ◆ 10-baseT/100-baseTX
 - ◆ Java VM
 - ◆ App2Me (must be installed by the technician during the machine's installation procedure)
 - ◆ Data Overwrite Security Unit
 - ◆ HDD Encryption Unit
- ❑ **SD cards**
 - ◆ Slot 1 (upper slot): Security SD Card (contains the Data Overwrite Security Unit and HDD Encryption Unit)
 - » Already installed at the factory; the technician does not have to do anything when installing the machine. However, the customer must activate them with user tools.
 - ◆ Slot 2 (lower slot): Empty when shipped from factory
 - » VM card with App2Me must be inserted during the machine's installation procedure.

Slide 3

- ❑ App2Me: More about this later.
- ❑ In the previous models, no SD cards were installed at the factory, and the Data Overwrite Security Unit and HDD Encryption Unit were options.



- Here is a view of the copier with some of the important options attached.
- The ARDF is an option.

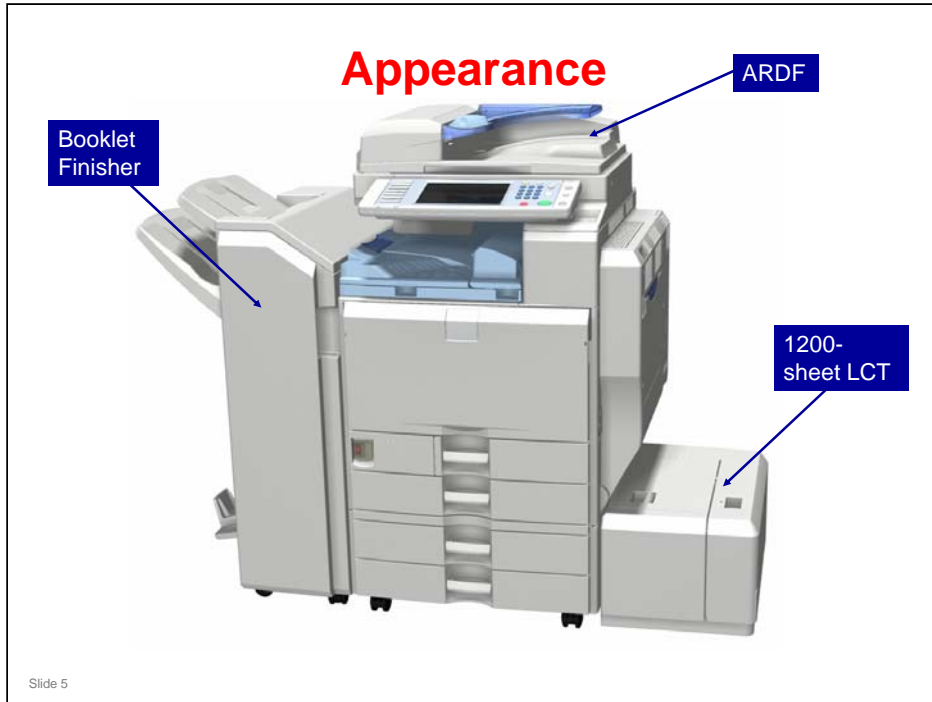

- ❑ Here is another view of the copier with some of the important options attached.

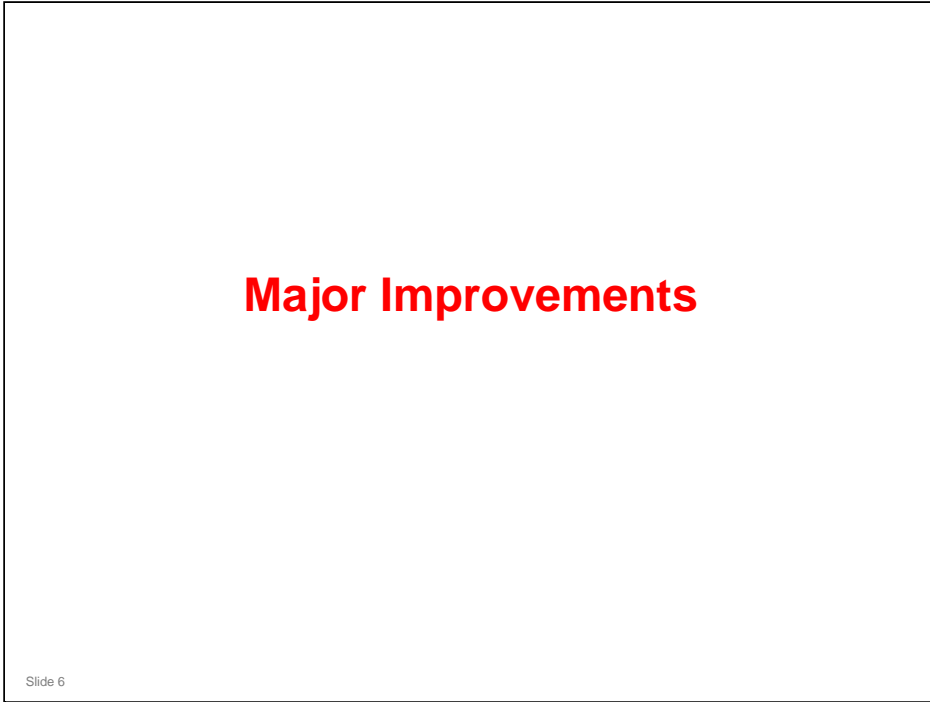

No additional notes

Main Technical Enhancements

- ❑ **Improved Productivity**
 - ◆ Color output up to 30 cpm (AT-C2.5a) and 35 cpm (AT-C2.5b)
 - » AT-C2a: 28cpm, AT-C2b: 33cpm
 - ◆ Fusing by induction heating
 - » Like the AP series
 - ◆ Optional Envelope Feeder
- ❑ **Advanced Solution Features**
 - ◆ Quota Setting
 - ◆ Printing from USB/SD card slot
 - ◆ Standard VM card
- ❑ **Handling Thick Paper up to 300g/m² from By pass**
 - ◆ AT-C2: up to 256g/m²
- ❑ **Lower energy consumption**

Slide 7

- ❑ **USB/SD card slot:** In previous models, the optional USB/SD card slot can only be used for scanning data to an SD card or USB device.

Connectivity/Software Improvements

- ❑ **Autumn 2009 based GW Controller (Minor upgrade version of the 09A GW controller)**
- ❑ **New Security/Authentication functions:**
 - ◆ SSLv2/SSLv3/TLS protocols can now be enabled/disabled
 - ◆ Support for SMTP over SSL (scan to webmail)
 - ◆ Intermediate CA Certificates support
- ❑ **New Printer driver/Printing functions:**
 - ◆ Support for removable storage devices has been added
- ❑ **New Scanner functions**
 - ◆ A signature can be included with messages sent using scan to e-mail
- ❑ **Other new features**
 - ◆ User quotas can now be set (job limits and page limits are available).
 - ◆ Device shutdown uses new safety functions to decrease HDD-related issues.
 - ◆ AZERTY soft keyboard (EU model only) support has been added.

Slide 8

No additional notes



No additional notes

Improvements in Basic Specs

	AT-C2	AT-C2.5
Print/Copy Speed	28 ppm (AT-C2a) 33 ppm (AT-C2b)	30 ppm (AT-C2.5a) 35 ppm (AT-C2.5b)
First Copy Speed (BW)	5 s	5 s
First Copy Speed (FC)	8 s	8 s
Warm-up Time	30 s (NA), 35 s (EU)	23 s
Recovery from Sleep Mode	24 s	15 s
Paper Weight	Tray/Bypass: 60-256g/m ² (16-68 lb. Bond/140 lb. Index)	Tray: 60-256g/m ² (16-68 lb. Bond/140 lb. Index) Bypass: 60-300g/m ² (16lb. Bond/170 lb. Index)
HDD	160 GB	160 GB
Memory	1 GB	1.5 GB
TEC (kW/h)	USA: 2.8 (AT-C2a), 3.2 (AT-C2b) EU: 3.1 (AT-C2a), 3.5 (AT-C2b)	USA: 1.69 (AT-C2.5a), 1.89 (AT-C2.5b) EU: 1.74 (AT-C2.5a), 1.94 (AT-C2.5b)

Slide 10

- ❑ The print/copy speed for full color is the same as for black-and-white.
- ❑ The print/copy speeds for other paper weights are as follows:
 - Thick 1, 2, 3 - 17.5cpm (increased from 16 cpm)
 - Thick 4 is a new paper type (up to 300 gsm) : 17.5 cpm (trays), 15 cpm (bypass)
 - OHP/Glossy - 17.5 cpm (increased from 16 cpm)
- ❑ Printing Paper Weight: Duplex and LCT are not changed from the previous model
- ❑ Scanning Throughput (ARDF mode) for Scan to E-mail / Folder
 - BW/FC: 51 ipm (A4LEF / BW Text / Line Art / 200dpi /Compression: On (MH)) – previous model was 50 ipm
- ❑ TEC: Total Energy Consumption

Reliability Targets

	AT-C2a	AT-C2b	AT-C2.5a	AT-C2.5b
ACV	5k/month	8k/month	5k/month	7k/month
Max CV	20k/month	20k/month	20k/month	20k/month
PM Interval	120k	120k	150k/200k	150k/200k
MCBC	47.3k	50.7k	46.6k	47.1k
Life	5 years or 1200k			

Slide 11

- ❑ MCBC: Mean copies between calls
- ❑ Lower target ACV for AT-C2.5b reflects actual field usage for AT-C2b. It does not mean that endurance is less.
- ❑ PM interval 150k/200k: Some parts are replaced on a 150k cycle, and some on a 200k cycle. See the PM table in the service manual for details.

Yield Targets

- ❑ **Developer**
 - ◆ K: Increased from 240k to 300k (a different material is used)
 - ◆ CMY: 240k (same material as AT-C2, but the quantity of developer in the bag is different)
- ❑ **Drum**
 - ◆ K: Increased from 120k to 200k
 - ◆ CMY: 120k (same as AT-C2)
- ❑ **Toner**
 - ◆ K: Increased from 20K to 22.5k
 - ◆ CMY: Increased from 15K to 16k
 - ◆ Do not leave the toner bottle in a place directly exposed to sunlight.
 - » The toner bottle must be kept at a temperature of 35° C (95° F) or less. Be careful not to leave the toner bottle in a hot place when transporting or storing it.
- ❑ **Fusing unit components**
 - ◆ Increased from 240k to 300k
 - ◆ For details on other components, see the PM table.

Slide 12

- ❑ The K toner, developer, and OPC are new.
- ❑ The CMY toner, developer, and OPC are the same as the previous series.
- ❑ The volume of CMY developer has been reduced because tests have shown that 240k can be guaranteed with a lower volume of developer.

Lower Energy Consumption

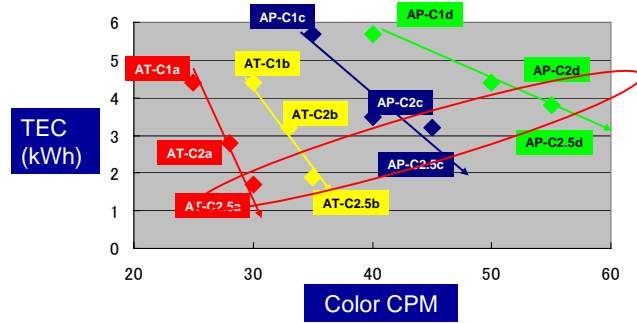

- The typical electricity consumption (TEC) is lower than previous models in this series.

Slide 13

No additional notes

New and Improved Features

Slide 14

No additional notes

Improved Document Solutions and Security

- ❑ **App2Me: This is a new document solutions product.**
 - ◆ Among other things, it allows you to take your preferred operation panel setup with you and use it when you operate any other copier that has this capability.
- ❑ **P2600: A hardcopy device and system security standard, sponsored by IEEE.**
 - ◆ There are four levels.
 - ◆ Ricoh is the only manufacturer of office equipment trying to obtain the highest level of P2600 security approval (suitable for military, government and other high security applications)

Slide 15

- ❑ P2600: Approval procedures were not yet complete at the time of writing.

App2Me

- ❑ App2Me is included on the VM card which is included with the machine in the carton box (not shipped in slot 2).
- ❑ It must be installed and enabled during machine installation.
 - ◆ The procedure is in the field service manual for the main machine.
 - » Near the end of the section for installing the main machine, see the 'VM Card Installation' section.

Slide 16

No additional notes

User Account Limiting

- ❑ This function allows the customer to set limits on the number of outputs for each individual user or group.
- ❑ The following applications can be managed with this function.
 - ◆ Copy
 - ◆ Print (including "Print from USB/SD")
 - ◆ Document Server
 - ◆ SDK
 - ◆ Fax related jobs and "Mail to Print" jobs can't be limited.
- ❑ User authentication must be enabled.
- ❑ Possible Settings
 - ◆ Stop Job: When the maximum print volume is reached, both the current job and waiting jobs are canceled.
 - ◆ Finish Job and Limit: When the maximum print volume is reached, the current job is allowed to finish, but waiting jobs are canceled.
 - ◆ Allow Continue Use (Default setting): Print volume is not limited.
- ❑ You can also set a 'count-per-page' setting for large paper sizes such as A3.

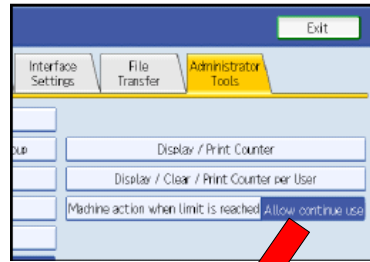

Slide 17

No additional notes

Scan to Web Mail (SSL over SMTP)



- ❑ **This function gives improved security for scan to e-mail.**
 - ◆ Gives better security when scanning to web mail.
- ❑ **Uses SSL encryption.**

Slide 18

- ❑ If this is enabled, internet fax to Ricoh GW models is not available because GW models do not comply with SSL reception at this time.

Print from USB/SD

- ❑ In previous models, the optional USB/SD card slot can only be used for scanning data to an SD card or USB device.
- ❑ However, in this new series, it is also possible to print from data stored on an SD card or USB device.
- ❑ If the customer wants to print PDF files from the USB/SD card slot, the PDF Direct option or Postscript 3 option must be installed.
 - ◆ The PDF Direct option is supplied with the USB/SD card slot option.

Slide 19

No additional notes

Duplex Printing from Bypass Tray

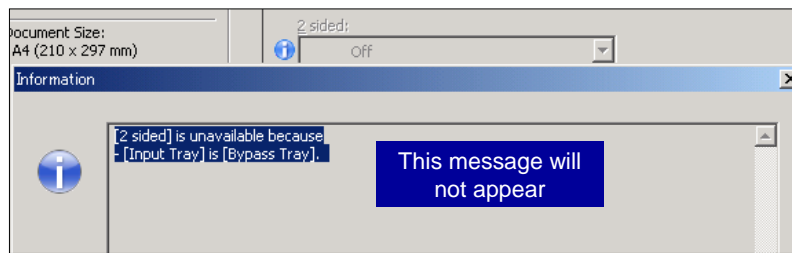

- ❑ In previous models, duplex copying/printing is not possible from the bypass tray.

Slide 20

No additional notes

Printing on Letterhead Paper

- **This setting changes the paper path.**
 - ◆ Off: Simplex pages go through the simplex path and duplex pages go through the duplex path.
 - ◆ Auto Detect: The paper path for simplex jobs with a paper type of "Letterhead", "Pre-printed" or "Pre-punched" is changed to the duplex path.
 - ◆ On (Always): The paper path for all simplex jobs with all types of paper is changed to the duplex path.
- **Simplex pages will still be counted as simplex jobs by the internal counter even if this setting is enabled.**

Slide 21

No additional notes

High Compression PDF with JPEG 2000

- ❑ Images are processed with MMR compression for text areas and JPEG 2000 compression for image areas.
- ❑ **JPEG 2000:**
 - ◆ The image is less noisy
 - ◆ There is also less noise around text, making it better for OCR use



Ricoh



Another
Maker

Slide 22

No additional notes

AZERTY Keyboard

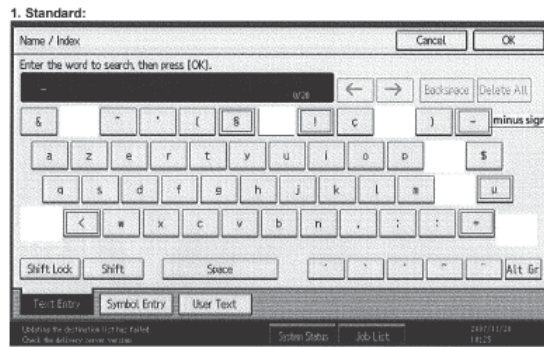

- ❑ If the language is changed to French, the keyboard changes as shown above.

Slide 23

- ❑ It is possible to switch to a QWERTY keyboard.
- ❑ This feature is for Europe only. The North American model will use the QWERTY keyboard, which is widely used in Quebec.

Color Weakness Management Mode



- ❑ This mode can be selected at the printer driver to help people with color weakness to distinguish between red and green.

Slide 24

- ❑ Color weakness is also known as partial color blindness. For example, some people cannot distinguish red from green; both colors appear as a yellowish brown, as shown on the slide.
 - It is said that between 5 and 10% of Caucasian males are red-green color blind.
 - There is another form of color weakness, involving yellow and blue, but this is more rare.
- ❑ This feature is available with PCL6 or PS3, operating on MS Office 2007.

Safe Shutdown

- ❑ In this machine, a power relay board protects the HDD unit.
- ❑ After the main power switch of the machine has been turned off, the power relay board keeps the power supply to the controller until the HDD unit has been shutdown safely.
- ❑ When shutting down from normal stand-by mode, if the safe shutdown takes more than 2 minutes, there is a problem with the controller board. It may be necessary to replace this board.

Slide 25

- ❑ This table shows how long it takes to shut down from various machine conditions.

Mode	Status	Details	Time to Shut Down
Stand-by	Stand-by	Stand-by Panel off Low power	Less than 10 s
		Operation SW off	0 s
Operation	Scanning Copying/Printing HDD deleting	-	Less than 20 s
	Firmware updating HDD encrypting	-	Less than 360 s
Error	SC issued	SC level A, D	Less than 360 s
		SC level B, C	Less than 10 s
	Application error	Application SD Removed	Less than 360 s
Starting up	Starting up	During 1 min. after application screen is displayed	Less than 80 s

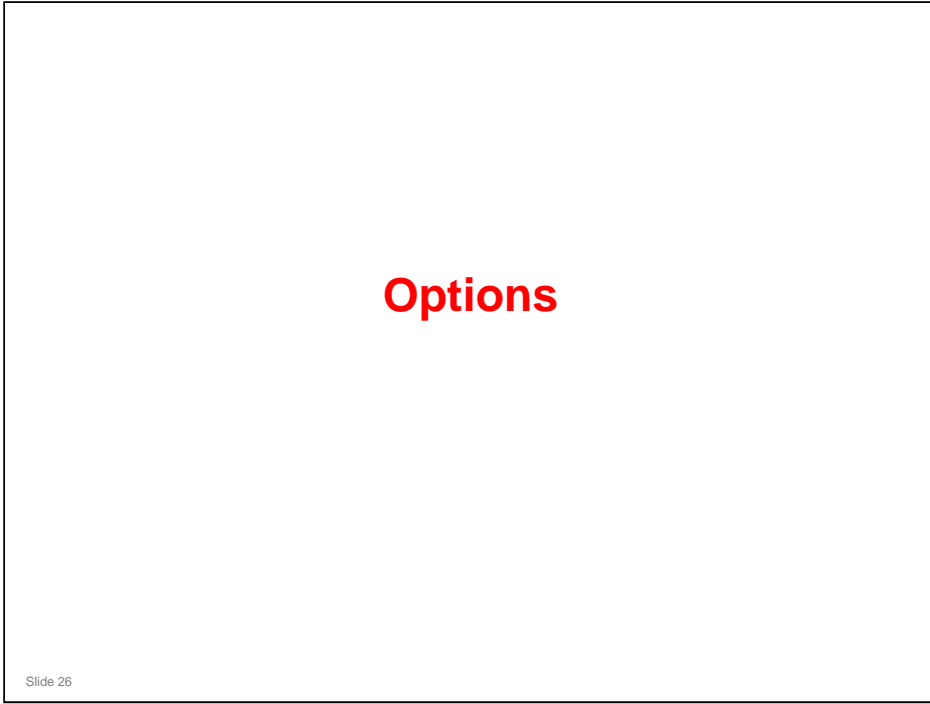

No additional notes

**Differences from the Previous Series
Paper Feed and Finishing Options**

- ❑ **New units, similar to the ones used in the AT-C2**
 - ◆ ADF
 - ◆ ADF Handle (Type B)
 - ◆ Paper tray unit (two trays)
 - ◆ Tandem LCT
 - ◆ Side LCT
 - » Requires the two-tray paper feed unit or LCT
 - ◆ One-bin tray
- ❑ **Completely new units**
 - ◆ Envelope feeder
 - » Can be installed in tray 2 of the main frame or any tray in the two-tray paper tray unit.
 - » Cannot be installed in the one-tray paper tray unit
 - ◆ Side tray (based on the bridge unit that was used with the previous series, with two trays attached)
 - » If the side tray is installed, the following options cannot be installed: finisher (any), bridge unit, shift tray
- ❑ **Same units as AT-C2**
 - ◆ Paper tray unit (one tray)

Slide 27

- ❑ The new but similar units are basically the same as the ones used with previous models. The software and some motors were changed to match the higher print speed of the new series.
- ❑ The envelope feeder was used in the Japan version of the AP-P2.
 - There is no automatic paper size detection in the envelope feeder. Adjust the paper size for the tray where the envelope feeder is to be installed with User Tools.
- ❑ Requirements for the side LCT: Same as the previous model, but the training material was not worded correctly

Differences from the Previous Series Connectivity and Other Options

- ❑ The following are new units. The other options are the same as in the previous series.
 - ◆ Fax option
 - ◆ PostScript
 - ◆ IPDS
 - ◆ PictBridge
 - ◆ Browser unit
 - ◆ USB/SD card slot
 - ◆ Fiery controller
- ❑ There is no optional VM card
 - ◆ It is shipped with the machine in the carton box (not shipped in slot 2).

Slide 28

- ❑ IPDS is new for the AT-series.

Slots

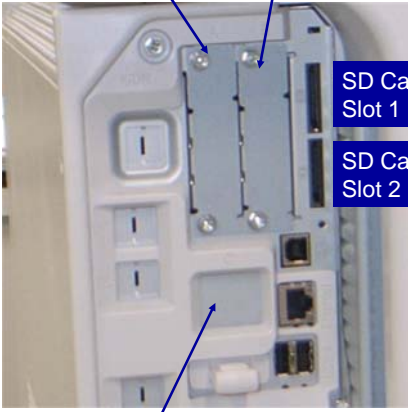

- ❑ **I/F Slot A is used for one of the following:**
 - ◆ IEEE1284
 - ◆ IEEE802.11a/g
 - ◆ Bluetooth
 - ◆ Remote Communication Gate.
- ❑ **I/F Slot B is used for one of the following:**
 - ◆ File Format Converter
 - ◆ Remote Communication Gate.
- ❑ **I/F Slot C is used for Gigabit Ethernet**

Slide 29

- ❑ The SD Card slots are discussed in more detail on the next few slides.

SD Card Slots – Slot 1

□ Slot 1 (upper slot)

- ◆ Contains the Security SD Card when shipped
 - » The Security SD Card contains the Data Overwrite Security unit and HDD Encryption Unit.
- ◆ Use when installing the following options
 - » PostScript
 - » PictBridge
 - » IPDS
 - » PDF Direct (child option for USB2.0/SD Slot)
- ◆ If you want to install more than one of these, move them onto one SD card.
- ◆ You cannot move the PostScript card or PDF Direct card. However, you can move the other SD cards to the PostScript card or PDF Direct card.

Slide 30

No additional notes

SD Card Slots – Slot 2

□ Slot 2 (lower slot)

- ◆ Empty when shipped; contains the VM card after the machine's installation procedure.
- ◆ Use this slot for service procedures, such as firmware update and NVRAM backup.
- ◆ Also use this slot to install the following SD card options.
 - » Browser unit
 - » VM card with App2Me
- ◆ When installing the Browser Unit, if the VM card with App2Me has already been installed, remove it, do the installation procedure for the browser unit (see the service manual), then put the VM card back in.
 - » During the installation procedure, the browser software is copied to the hard disk inside the machine.

Slide 31

No additional notes

Removing the VM Card

- ❑ To remove the VM card with an active application such as App2Me, just turn off the machine in the normal safe way (first operation switch, then main power switch), then pull the card out.
- ❑ The procedure used for previous models with App2Me (V-C3, AL-C1.5, R-C5.5) is still recommended, but not necessary.

Slide 32

- ❑ Recommended procedure for halting VM card applications such as App2Me before you remove the VM card.
 - Normally, you need to remove the VM card at these times: To update the firmware, To back up the NVRAM, To install the browser unit, To update the App2Me application firmware, To execute application move or undo with SP5873
- ❑ To halt the VM card applications, do the following steps:
 - 1. Push the "User/Tools" key.
 - If an administrator setting is registered for the machine, step 2 and 3 are required. Otherwise, skip to step 4.*
 - 2. Push the "Login/Logout" key.
 - 3. Login with the administrator user name and password.
 - 4. Touch "Extended Feature Settings" twice on the LCD.
 - 5. Touch each application until the status changes to "Stop".
 - You must stop each application before you remove the VM card.*
 - 6. Turn off the machine. And then remove the VM Card.
- ❑ After the firmware update, NVRAM backup, etc, then you have to enable App2Me and the other extended features again. To do this:
 - 1. Put the VM card in its slot. Then turn the main power on.
 - 2. Press the "User Tools" key on the operation panel.
 - If an administrator setting is registered for the machine, steps 3 and 4 are required. Otherwise, skip to step 5.*
 - 3. Push the "Login/Logout" key.
 - 4. Login with the administrator user name and password.
 - 5. Touch the "Extended Feature Settings" button twice.
 - 6. Touch each application that you use. The status will change to 'On'.
 - 7. Touch the "Exit" button. 9. Exit the "User Tools/Counter" settings.

Card Authentication Package (CAP)

- ❑ Requires the Card Reader Bracket Type C5501.
 - ◆ The card reader must be placed on this card reader table, or there may be interference between the card reader and an antenna or transmitter in the main machine.

Slide 33

- ❑ The IC card reader is not supplied by Ricoh and must be procured locally.

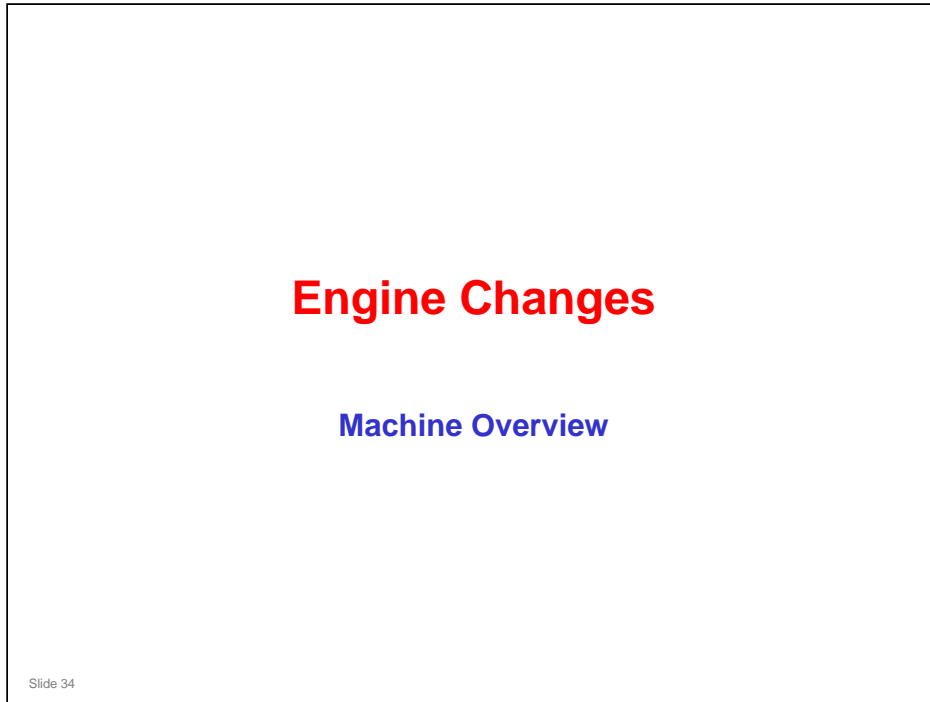

No additional notes

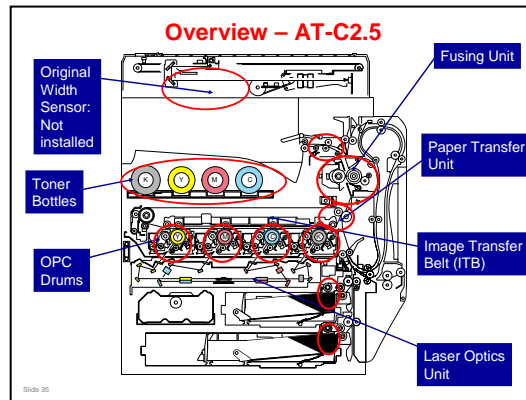

- ❑ This is a view of the internal structure of the machine.
- ❑ Major differences from the AT-C2 are indicated with a red circle.
 - The order of drums has been changed (see the next slide to compare with the previous model). This change has improved the uneven toner density problems that occurred with the previous model.
 - Changes to the drum unit: Details later
 - Toner end sensor for K removed
 - Three ID/MUSIC sensors (the previous series had 5)
 - Belt added to pick-up rollers in paper trays
 - Paper transfer unit - Pressure springs were changed
 - Fusing unit: Induction heating (IH) is used for the first time in this series
 - The fusing unit does not contain a fusing belt. The IH inverter heats the roller directly.*
 - The unit is basically the same as the AP-C2.5, except for the dimensions of some rollers.*
 - Paper exit: Decurler has only two rollers

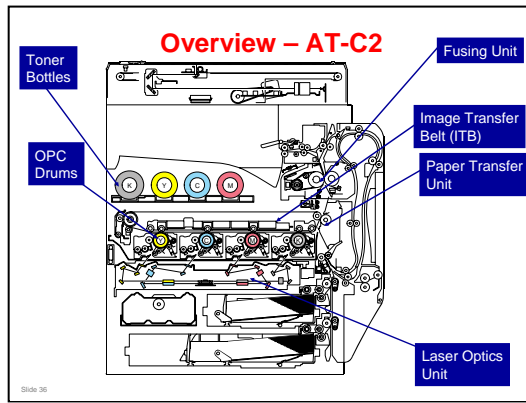

❑ Here is the previous model, for comparison.

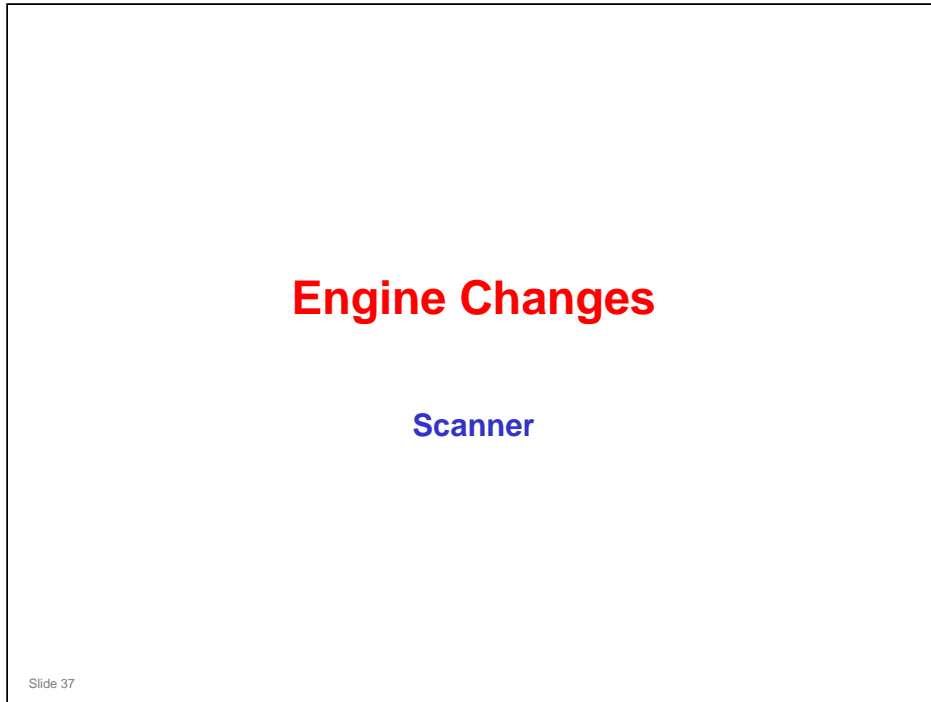

No additional notes

No Original Width Sensors

Previous Model
New Model

- ❑ In the new model, there are no original width sensors.
- ❑ The CCD detects the original width.
 - ◆ The CCD monitors three positions (S1, S2, S3).
 - ◆ The threshold value for the presence or absence of paper is 32. If the value is less than 32, the CCD detects no paper.

Slide 38

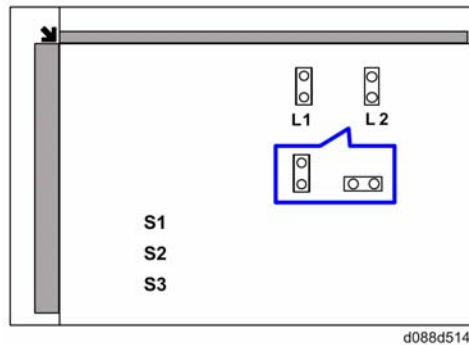

- ❑ The operation of original length sensors can be checked with SP4-301-001. The signals from S1, S2 and S3 can be checked with SP4-310.

Original Size		Width Sensor (CCD)			Length Sensor		SP4-301 display
Metric	Inch	S1	S2	S3	L1	L2	
A3	11" x 17"	O	O	O	O	O	00000011
B4	10" x 14"	O	O	X	O	O	00000011
F4	8.5" x 13", 8.25" x 13", or 8" x 13" Depending on SP 5126	O	X	X	O	O	00000011
A4 LEF	8.5" x 11"	O	O	O	X	X	00000000
B5 LEF	-	O	O	X	X	X	00000000
A4 SEF	11" x 8.5"	O	X	X	O	X	00000010
B5 SEF	-	X	X	X	O	X	00000010
A5 LEF	5.5" x 8.5"	O	X	X	X	X	00000000
A5 SEF	8.5" x 5.5"	X	X	X	X	X	00000000

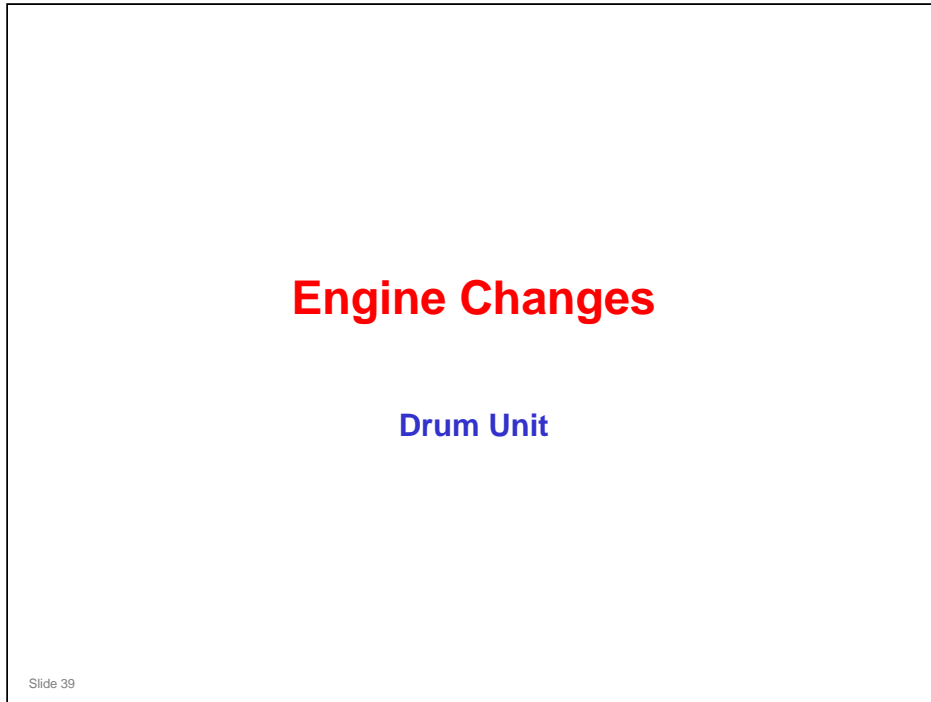

No additional notes

Drum Unit

The following components were improved:

- ◆ Charge Roller (KCMY): Material change to reduce surface dirt.
- ◆ Cleaning Blade (K only): Angle change to improve cleaning.
- ◆ Lubricant Bar (K only): Material change for a more stable supply of lubricant, and to match the longer PM interval.
 - » The lubricant bar for the K drum unit is longer than for the CMY drum units.
- ◆ Development Sleeve (K only): Material change to improve reliability

Slide 40

The drum unit is one part of the PCDU (Photoconductor and Development Unit).

- In the previous model, this was called the PCU, not the PCDU.

Drum Unit – Previous Model

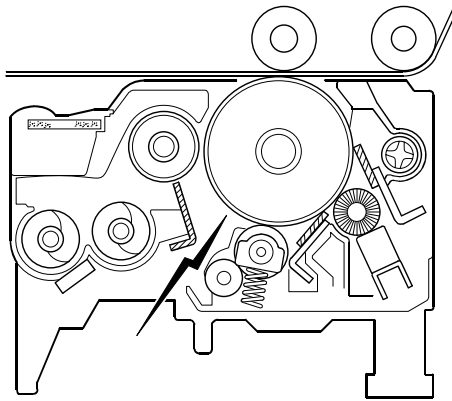

Slide 41

- ❑ The drum unit for the previous model is shown for comparison.

Engine Changes

Development and Toner Supply

Slide 42

No additional notes

Development and Toner Supply

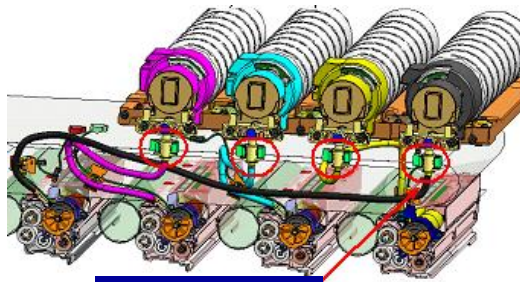

Toner end sensor
deleted for K

- ❑ For K, the toner end sensor in the toner supply unit (the entrance of the toner supply tube) was deleted. Toner end is detected by the TD sensor in the development unit.
- ❑ For all four colors, near-end is detected by monitoring the total operating time of the toner attraction pump.

Slide 43

- ❑ Note that the order of CMY from left to right is not shown correctly in this diagram. The positions of cyan and magenta should be exchanged.

Toner End Detection

The diagram illustrates the toner end detection mechanism. It shows a toner cartridge with a 'Toner End Sensor (CMY only)' located at its tip. Below the cartridge is a 'TD Sensor' assembly, which is a small probe that detects the toner level in the drum. The TD sensor is used for black toner, while the toner end sensor is used for CMY toner.

- ❑ To detect toner end, the machine uses the TD sensor (for black) color or the toner end sensor (for CMY).
 - ◆ The machine must first be in a toner near-end condition, or toner end cannot be detected.
- ❑ Toner end for black is detected if both the following conditions occur:
 - ◆ $VT - VTREF$ greater than or equal to "0.5" (SP3-101-021)
 - ◆ $SUM (VT - VTREF)$ greater than or equal to "10" (SP3-101-026)
- ❑ Toner end for CMY is detected if the toner end sensor detects toner end.

Slide 44

No additional notes

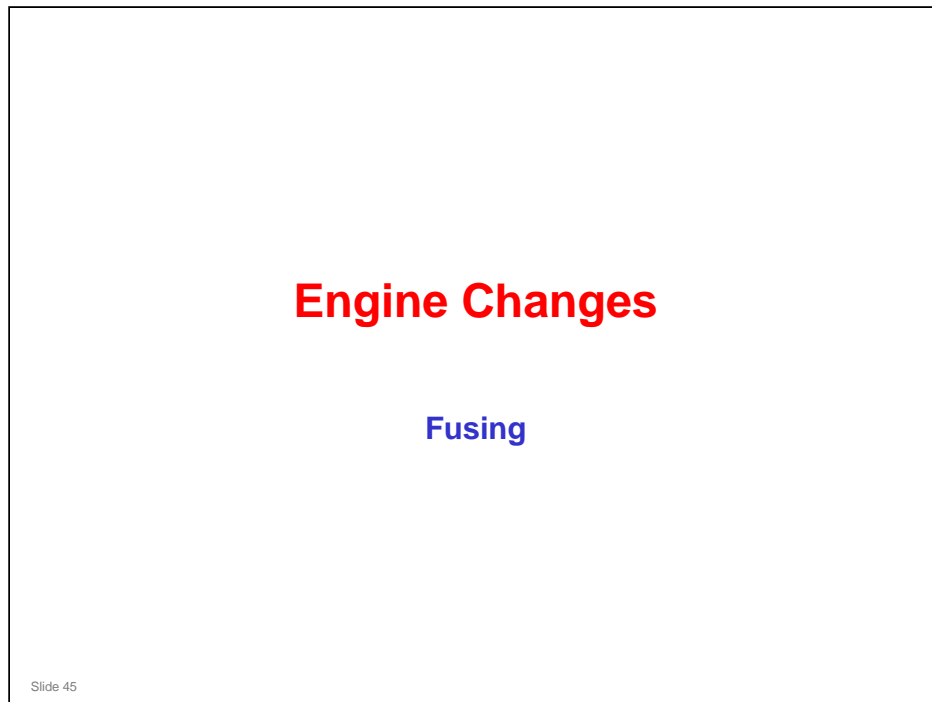

For details about fusing temperature control and CPM down mode, see the following files in the Reference Material folder.

- CPM Down System.pdf
- Paper Feeding Target Temperature for each Paper Type – AT-C25.pdf

Fusing

- ❑ **Uses the same heating system as the AP-C2.5 (induction heating).**
 - ◆ The rollers have smaller diameters than the AP-C2.5.
 - ◆ The heating roller is made from a different material than the AP-C2.5.
 - » In the AP-C2.5, the heating roller may start to break up if used for longer than 330k, so the machine monitors the heating roller rotation and when the roller is replaced, the counter must be reset with an SP mode.
 - » With the AT-C2.5, this is not a problem.

Slide 46

- ❑ Previous models in this series did not use the induction heating system. They used a fusing belt.
- ❑ The induction heating (IH) system will be explained in an appendix to this training course.

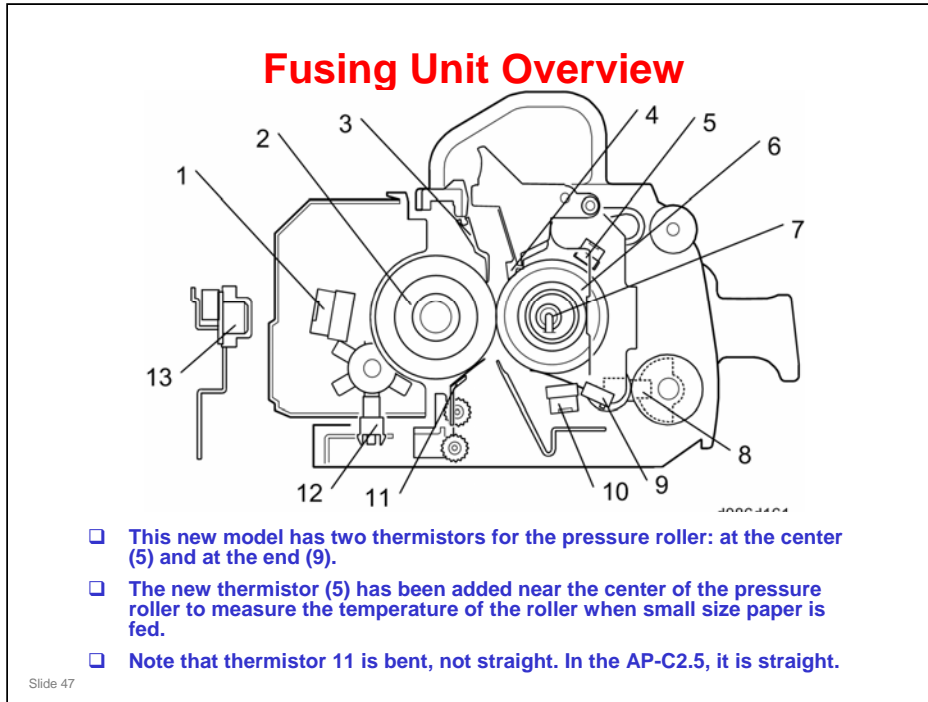

- ❑ 1. Heating roller thermostat
- ❑ 2. Heating roller
- ❑ 3. Heating roller stripper plate
- ❑ 4. Pressure roller stripper plate
- ❑ 5. Pressure roller thermistor: Center
 - This thermistor is not exactly at the center of the pressure roller: it is positioned so that when small paper or envelopes are fed, the thermistor is just beyond the edge of the paper, and is measuring the roller temperature directly, with no paper.
- ❑ 6. Pressure roller
- ❑ 7. Pressure roller fusing lamp
- ❑ 8. Pressure roller contact sensor
- ❑ 9. Pressure roller thermistor: End
- ❑ 10. Pressure roller thermostat
- ❑ 11. Heating roller thermistor
- ❑ 12. Heating roller rotation sensor
- ❑ 13. Thermopile
- ❑ Thermistors 9 and 11 are non-contact thermistors in this model. But in the AP-C2.5, they are contact thermistors.

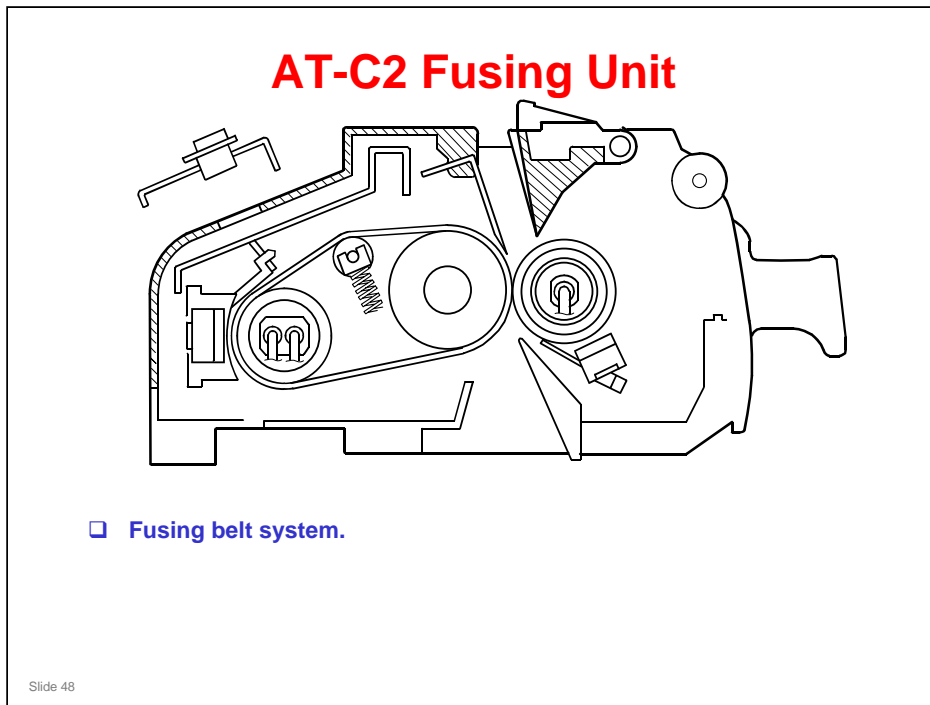

- This slide is for you to compare with the AT-C2.

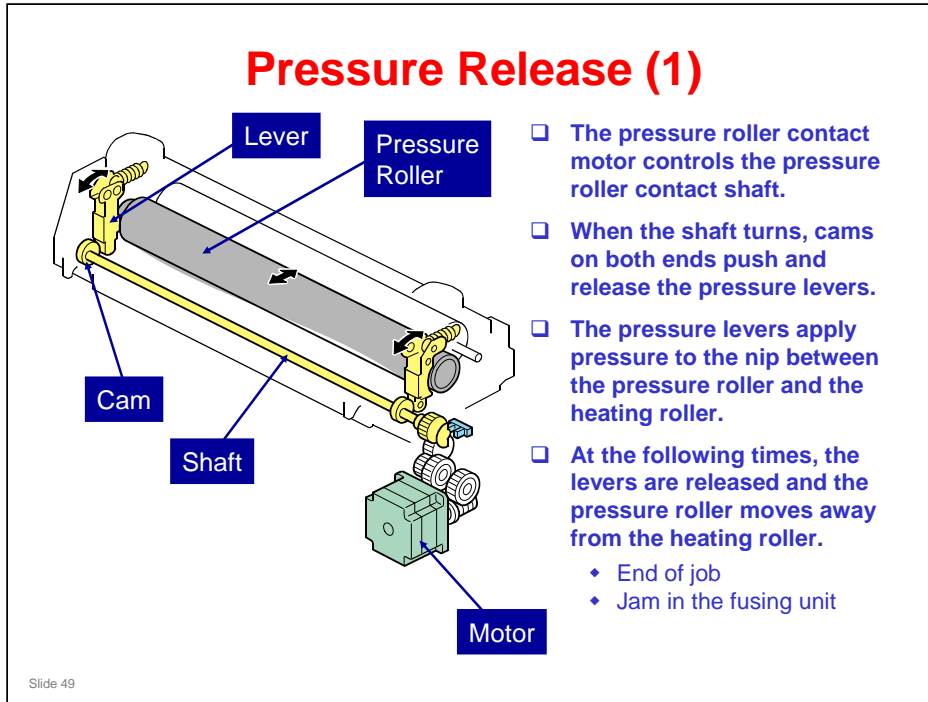

- ❑ This mechanism makes it easy to remove jams in the fusing unit.

Pressure Release (2)

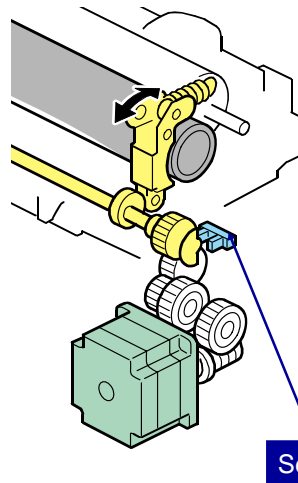

- If the pressure roller contact sensor cannot detect the actuator three times consecutively when initializing the pressure roller position or at job end, SC569 is issued.

Slide 50

No additional notes

Pressure Release (3)

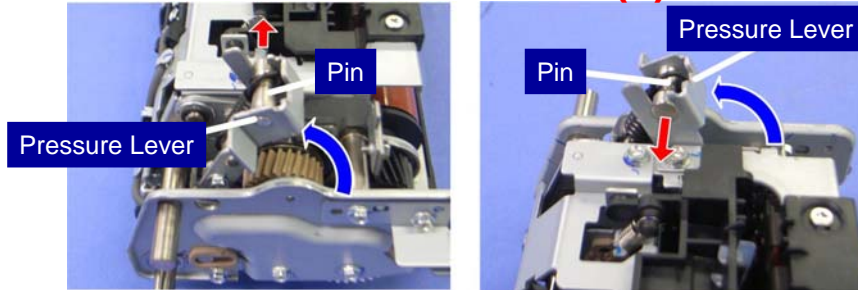

- ❑ When you disassemble the fusing unit, it is important to release the pressure after you remove the covers.
 - ◆ Turn both pressure levers, and pull out both pins.
- ❑ If you do not do this, the frames may become bent.
- ❑ See the service manual for details.

Slide 51

Service Manual, Replacement and Adjustment, Fusing, Heating Roller and Heating Roller Bushing

- ❑ Step 7 shows how to release the pressure.

Fusing Pressure Control Mechanism

Pressure Roller Actuator

Pressure Roller Contact Sensor

- ❑ **The pressure roller contact motor drives this mechanism.**
 - ◆ When it turns counterclockwise (CCW), pressure is applied.
 - ◆ When it turns clockwise (CW), pressure is released.
- ❑ **There are 4 positions, P0, P1, P2, and P3.**
 - ◆ P0: No pressure
 - ◆ P3: Highest pressure
- ❑ **Normally, P3 is used for printing, except for thick paper, special 3, and envelopes (P1 is used for these)**

Slide 52

- ❑ Pressure position change from P2 to P3 is as follows:
- ❑ From P2, turns CW until the sensor detects the edge of the actuator. Then turns CCW to the P3 position.
- ❑ The motor never turns past the edge of the actuator. When returning to the P0 position, the motor turns CW, so that all pressure is released. This prevents excessive torque on the contact motor's shaft.

Fusing Pressure Control

Operation Timing: Comparison with AP-C2

- ❑ **AP-C2: Pressure is released 5 minutes after the end of the job.**
- ❑ **AP-C2.5: Pressure is released immediately after the last page leaves the fusing unit.**

Slide 53

- ❑ The mechanisms in the AP-C2.5 and the AP-C2 are both a bit noisy, so customers may complain.
- ❑ The timing of the release can be changed with SP 1-151-10.

Fusing Pressure Control Adjustments

- **SP1151-001: Pressure Change ON/OFF**
 - ◆ If this is set at 'off', the two rollers always contact.

Slide 54

No additional notes

Cleaning Felt - 1

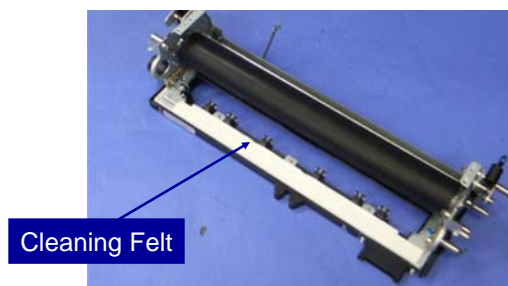

- ❑ The fusing cleaning felt is on the left edge of the fusing bottom cover.
- ❑ The toner used by this machine contains wax, to make it easier to remove toner from the heating roller.
 - ◆ Because of this, excess wax remains on the inside of the IH coil unit, and then moves back to the heating roller and finally to the paper.

Slide 55

No additional notes

Cleaning Felt - 2

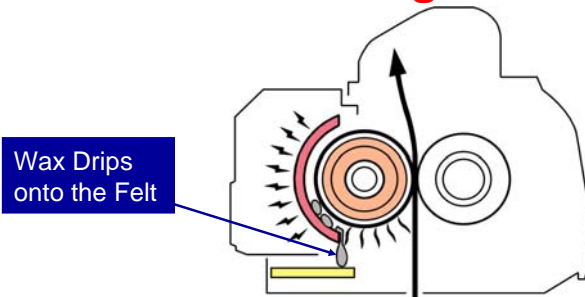

- ❑ **To remove the excess wax, there is a fusing cleaning mode.**
 - ◆ In this mode, the fusing rollers rotate with the IH coil "ON".
 - ◆ As a result, wax adhered to the inside of the IH coil unit melts, and drips onto the fusing cleaning felt.
 - ◆ The fusing cleaning felt absorbs the wax and prevents it from moving back to the paper.

Slide 56

- ❑ More about fusing cleaning mode: see the next slide.

Fusing Cleaning Mode

- ❑ The fusing cleaning mode (to remove excess wax) is executed for 160 seconds only when the following two conditions occur:
 - ◆ Execution counter (SP1153-004) > Execution interval (SP1153-002)
 - ◆ When extended fan rotation is not executed.
- ❑ However, for this machine, fusing cleaning mode is disabled by default, because the toner for this model is improved.
 - ◆ SP1153-002 is set to "0" (default)
- ❑ If there are black stains on the image, the technician can do manual cleaning by executing SP1153-001.

Slide 57

- ❑ Extended fan rotation: New fan control system. Will be explained later in this presentation.
- ❑ The fusing cleaning mode is disabled by default in this model, to prevent excessive intervals between jobs, which may cause some users to worry.

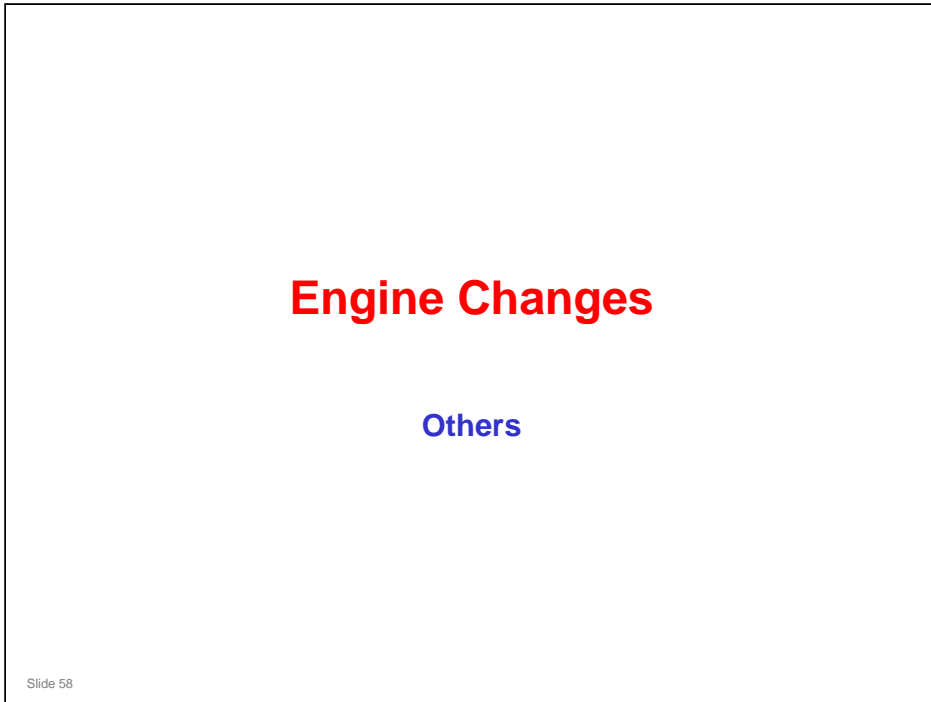

No additional notes

Paper Weights

- ❑ Thin paper: Below 60 g/m² (16 lb.)
- ❑ Normal plain paper 1 and 2: 60 – 90 g/m² (16 – 24.0 lb.)
- ❑ Middle Thick: 91 – 105 g/m² (24.2 – 28 lb.)
- ❑ Thick 1: 106 – 169 g/m² (28.5 – 44.9 lb.)
- ❑ Thick 2: 170 – 220 g/m² (45 – 58 lb.)
- ❑ Thick 3: 221 – 256 g/m² (58.7 – 68 lb.)
- ❑ Thick 4: 257 – 300 g/m² (68.4 – 79.8 lb.)

Slide 59

No additional notes

ID/MUSIC Sensors

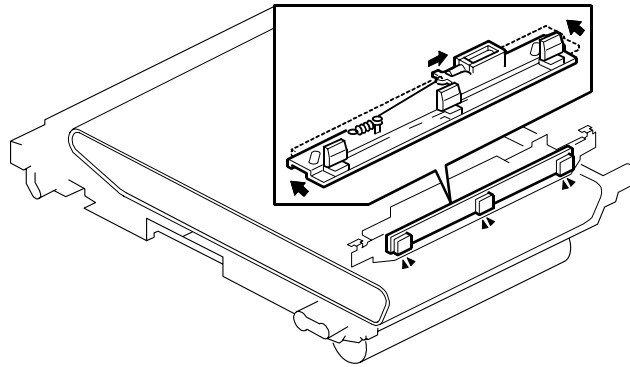

- ❑ **There are only three sensors in this new series.**
 - ◆ MUSIC (line position adjustment): Uses the front, center, and rear sensors
 - ◆ Process control: Uses the center sensor only

Slide 60

- ❑ There were 5 sensors in the previous series.

Paper Feed

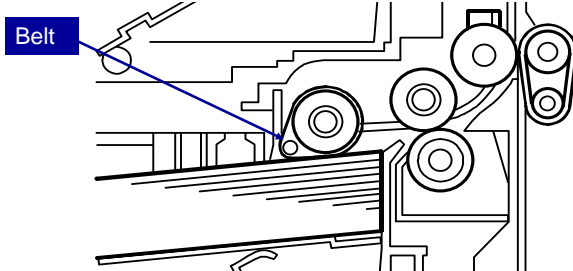

- ❑ **Pick-up roller: Changed to a pick-up belt, to improve paper pick-up.**
 - ◆ The area of contact between the belt and the paper is much larger than with a roller. As a result, this improves paper separation.
- ❑ **Paper tray:**
 - ◆ C2: Tray locked when a paper jam occurs.
 - ◆ C2.5: Tray not locked even when a paper jam occurs.

Slide 61

- ❑ This pick-up belt is also used in the optional two-tray paper tray unit, but not in the optional one-tray paper tray unit.

Paper Transfer Unit

- The paper transfer unit has two pressure springs (at the front and rear side).
 - ◆ On the previous model, the pressure from these springs causes some vibrations.
 - ◆ Spring pressure in the new model causes fewer vibrations. This improve the image evenness.

Slide 62

No additional notes

Paper Exit: Decurler

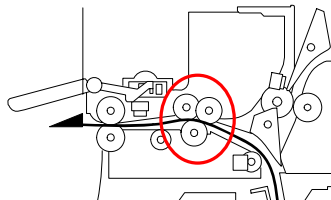

Previous Model –
Three Rollers

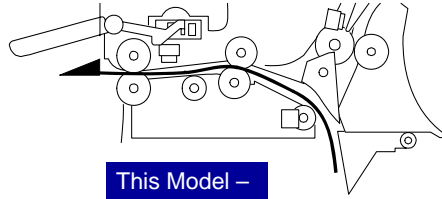

This Model –
Two Rollers

- ❑ In the new model, the bottom roller is a hard roller, and the top roller is a soft roller.
- ❑ The new system is better at preventing paper creasing.

Slide 63

No additional notes

Drive Unit: Fans

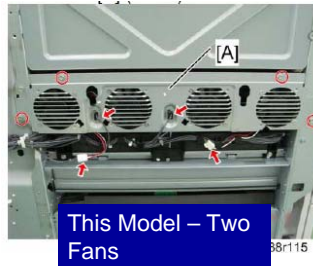
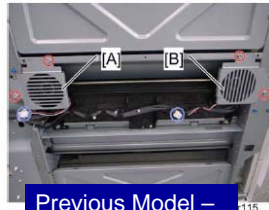

- ❑ **The AT-C2.5 has 2 fans.**
 - ◆ The AT-C2.5 uses the same bracket as the AP-C2.5, but has only 2 fans installed.

Slide 64

- ❑ The diagram on the right shows the AP-C2.5.

Replacement and Adjustment

Slide 65

No additional notes

Minor Changes in all Sections

- **Notable changes**
 - ◆ Laser unit: Changes to the SP adjustment procedure after replacement
 - ◆ Drive unit: SP Adjustment after replacing the gear unit - small changes to the SP adjustment
- **Refer to the correct service manual when working on the machine.**

Slide 66

- See the next few slides for other notable changes.

After Replacing the ID/MUSIC Sensors



- There are only two SP settings, as shown above.

Slide 67

No additional notes

PCDU

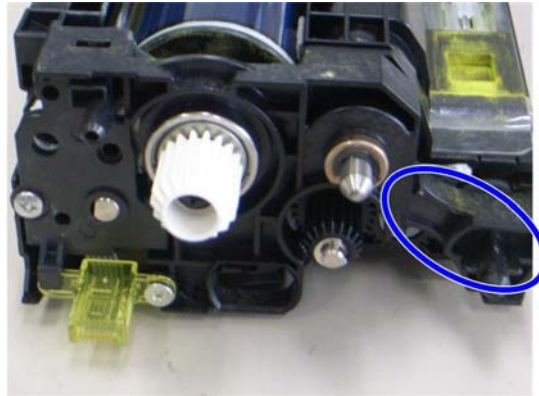

- ❑ Do not put too much weight on the PCDU, or the plastic frame of the development unit may be damaged.

Slide 68

- ❑ The blue circle shows where the damage could occur.

Fusing

- These procedures are all different from the previous model.
- The procedures are basically the same as the AP series.
 - ◆ These are different from the previous models in the AT series, so refer to the correct manual when servicing the machine.

Slide 69

No additional notes

Fusing Unit – PM Counters

- ❑ **If you will replace the heating roller or pressure roller in the fusing unit (at PM for example), then set the following SPs before you start the replacement procedures.**
 - ◆ Heating roller: Set SP 3902-018 to "1" before you start the replacement procedure
 - ◆ Pressure roller: Set SP 3902-019 to "1" before you start the replacement procedure
- ❑ **If you do this, then the machine will reset the PM counter automatically after you turn the power on again.**
- ❑ **It is not necessary to clear the PM counter for the fusing unit when you replace the fusing unit.**
 - ◆ This is because the fusing unit has a new unit detection mechanism.

Slide 70

No additional notes

Stripper Plate Installation

- ❑ A stripper plate may come off when you remove the heating roller or pressure roller.
- ❑ Follow the procedures in the service manual when replacing a stripper plate:
 - ◆ Heating Roller Stripper Plate
 - ◆ Pressure Roller Stripper Plate

Slide 71

Replacement and Adjustment – Fusing – Heating Roller and Heating Roller Bearing

Replacement and Adjustment – Fusing – Pressure Roller and Pressure Roller Bearing

Cleaning the Entrance Guide Plate



- ❑ The fusing entrance guide plate requires cleaning maintenance every 300 K.
- ❑ Clean the fusing entrance guide plate at the place shown above with a dry cloth, and then clean the fusing entrance guide plate again with a cloth moistened with alcohol.

Slide 72

No additional notes

Cleaning the Exit Guide Plate

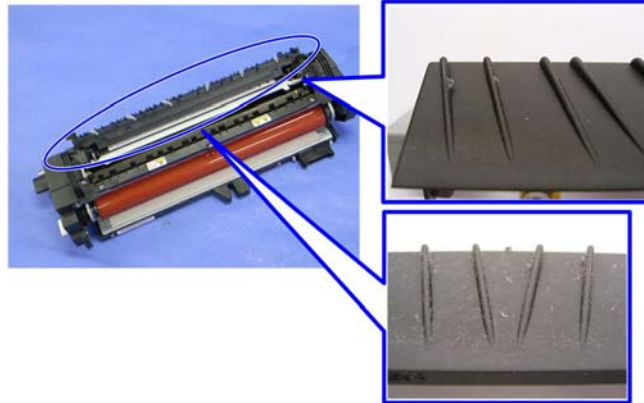

- ❑ The fusing exit guide plate requires cleaning maintenance every 300 K.
- ❑ Clean the exit guide plate with a dry cloth, and then clean it again with a cloth moistened with alcohol at the points shown above.

Slide 73

No additional notes

Cleaning the Stripper Plates

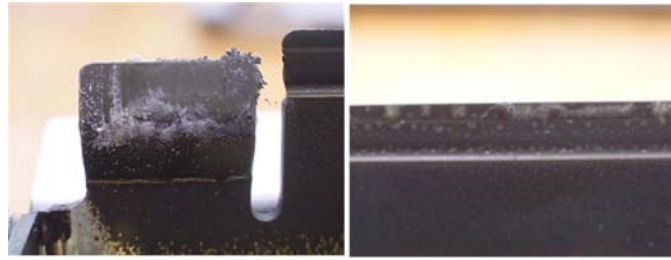

d037r377

- ❑ The stripper plates require cleaning maintenance every 300 K.
- ❑ Clean the stripper plates with a dry cloth, and then clean the stripper plates again with a cloth moistened with alcohol at the points shown above.

Slide 74

No additional notes

SP Operation Sound

- Beeps made by the machine when you are using SP mode can be disabled.
- There is a procedure in the Installation section of the service manual (SP Operation Sound On/Off Setting).
- In previous models, this is only possible with a user tool setting.

Slide 75

No additional notes

**Notes for Replacement
IH Coil Unit**

Thermostat

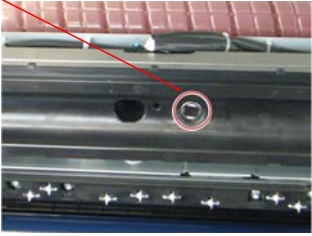

Do not push the thermostats on the IH coil unit. They break easily.

Slide 76

No additional notes

Notes for Replacement Cleaning the Thermopile



- ❑ Clean with a cotton-swab dipped in alcohol. Do this cleaning procedure after the fusing unit has completely cooled down. Otherwise, you may get a serious burn.
- ❑ Clean the thermopile every 200k.

Slide 77

No additional notes

Attaching a New Fusing Cleaning Felt

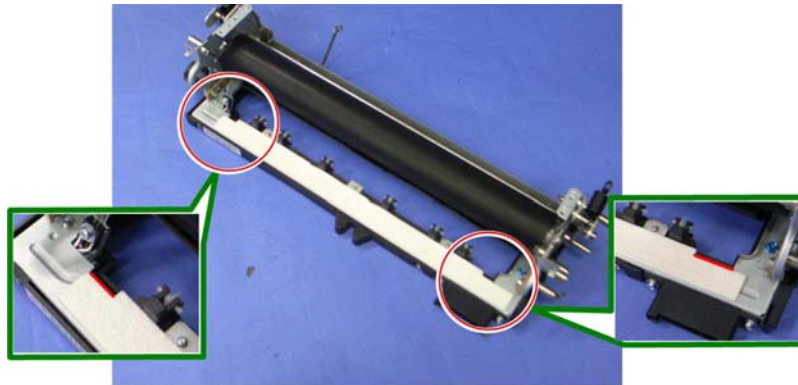

- ❑ When you attach the fusing cleaning felt, align both edges of the fusing cleaning felt with the red lines on the bottom cover.
- ❑ Make sure that the fusing cleaning felt is correctly attached to the frame. Otherwise, dust from the IH coil unit may fall on the paper in the fusing unit and the output becomes dirty.

Slide 78

No additional notes

SP1123-002

- If a stain appears on the output, do the following procedure.
 - ◆ Execute the fusing cleaning mode with SP1123-002.
 - » It takes 160 seconds to complete the fusing cleaning mode.
 - ◆ Make a sample copy, and then check if a stain appears on the output.

Slide 79

No additional notes



Troubleshooting

New Procedures

Slide 80

No additional notes

New Procedures

- **The following troubleshooting procedures have been added to the service manual.**
 - ◆ Toner End Recovery Error (toner end is displayed in the following conditions)
 - » After a new toner bottle has been installed in the machine
 - » When a displayed color toner bottle still has toner inside
 - ◆ Uneven toner density in solid image or halftone image
 - ◆ Black or color lines (2-3mm intervals)
 - ◆ Band between 20mm and 30mm from the leading edge

Slide 81

Troubleshooting – Troubleshooting Guide

Defects at Regular Intervals on Prints

- Colored spots at 47-mm intervals: Development roller**
- Abnormal image at 51-mm intervals: ITB drive or bias roller**
- Abnormal image at 85-mm intervals: Paper transfer roller**
- Colored spots at 119-mm intervals: Drum**
- Abnormal image at 101-mm intervals: Fusing unit (Pressure roller)**
- Abnormal image at 107-mm intervals: Fusing unit (Heating roller)**

Slide 82

No additional notes

Appendix

IH (Induction Heating) System for Fusing

Slide 83

No additional notes

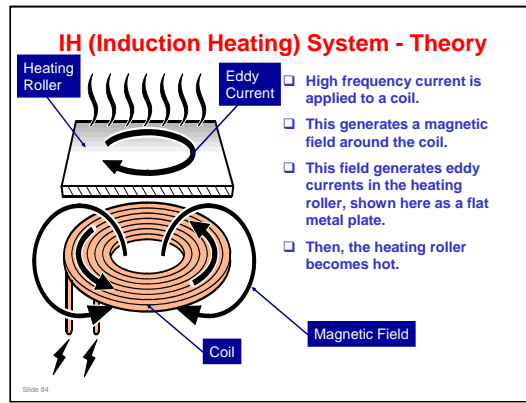

- ❑ This slide shows the basic theory.
- ❑ The surface of the heating roller is represented here by a flat metal plate.

Induction Heating System – This Machine

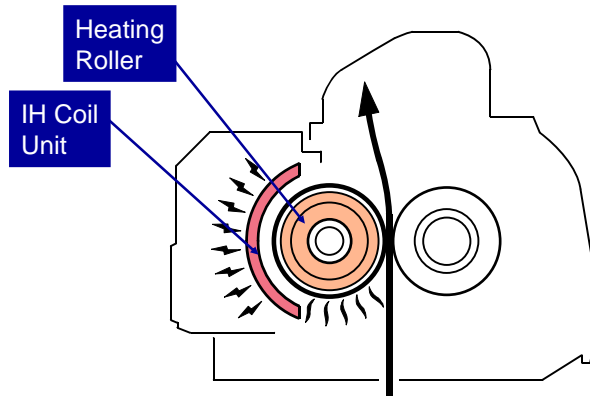

- ❑ The IH coil unit heats the heating roller directly.
- ❑ The inner surface of the heating roller sleeve contains a metal sheet.

Slide 85

No additional notes

Heating Roller Rotation Sensor

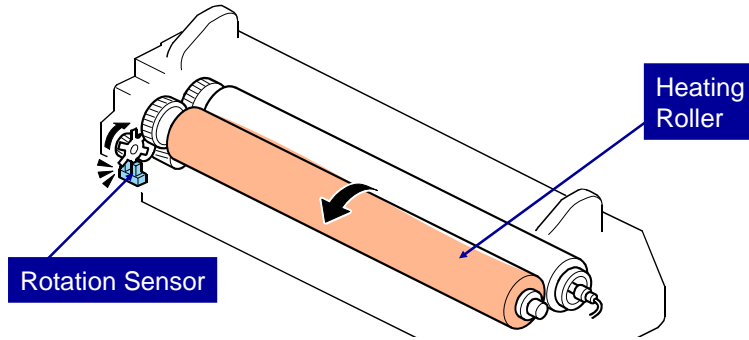

- ❑ The heating roller rotation sensor monitors the rotation of the heating roller.
- ❑ If this sensor does not detect the edge of the actuator for 500 ms, the machine issues SC548 and stops the machine
- ❑ If the heating roller does not rotate, the same place of the heating roller sleeve is continuously heated, and this can cause overheating.

Slide 86

No additional notes

Correction for Paper Size

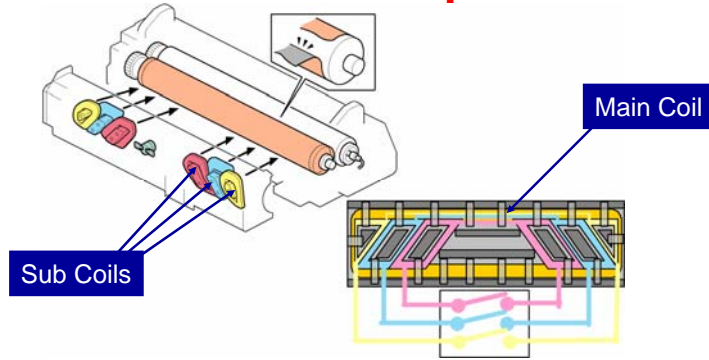

- ❑ The IH coil unit has a main coil and three sub coils.
- ❑ The machine changes the combination of sub coils depending on the selected paper size for a job.
- ❑ When the selected sub coil is turned on, the selected area on the main coil generates eddy currents and heats the metal sheet inside the heating roller sleeve.

Slide 87

No additional notes