

**1 Bin Tray BN3080
Machine Code: D536
Field Service Manual**

6 August, 2010

TABLE OF CONTENTS

1. Replacement and Adjustment

Electrical Components.....	3
Paper Sensor.....	3
1-Bin Control Board.....	4
INDEX	7



1. Replacement and Adjustment

Electrical Components

1

Paper Sensor

1. Open the right door of the machine.

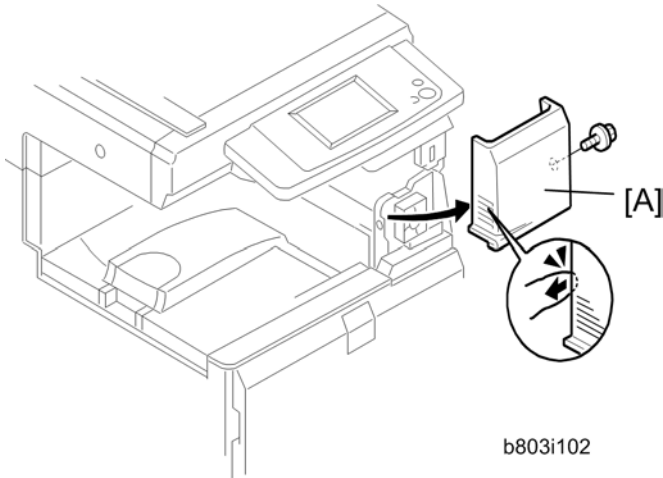

2. Remove the front right cover [A] ( x 1).

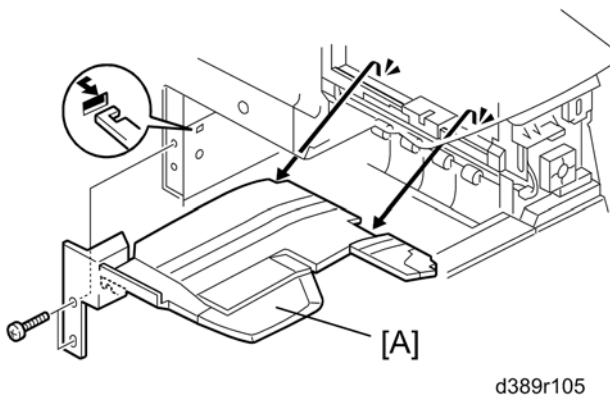

3. 1-bin-tray [B] ( x 2; M3 x 16)

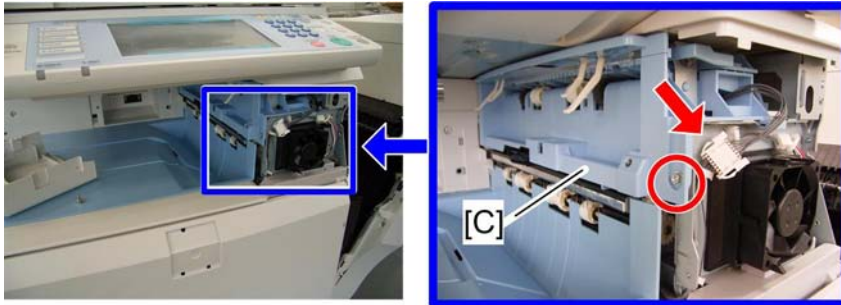

b803r501

4. 1-bin sorter unit [C]

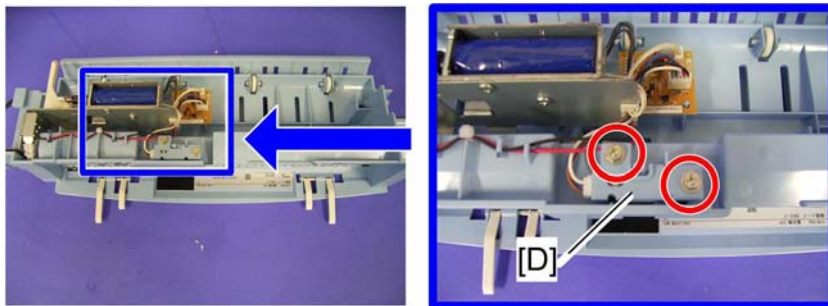

b803r502

5. Paper sensor cover [D] ( x 2)

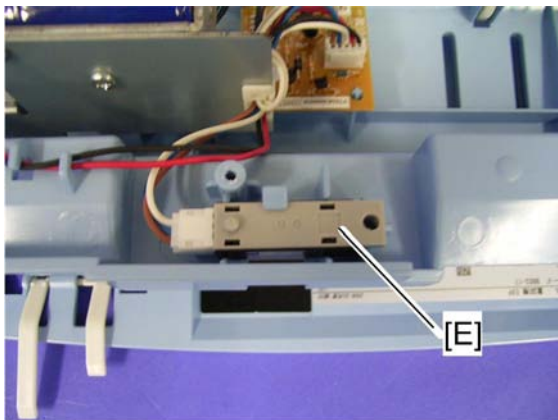

b803r503

6. Paper sensor [E] ( x 1, hook)

1-Bin Control Board

1. 1-bin tray
2. 1-bin sorter unit ( "Paper Sensor")

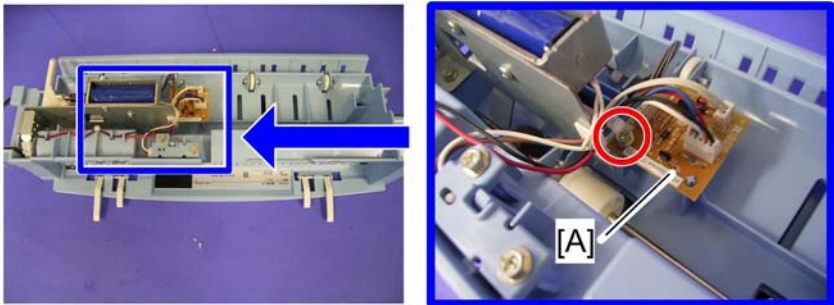

b803r504

3. 1-bin control board [A] (PCB x 1, IC x 3)

