

**Fax Option Type C5501  
Machine Code: D545  
  
Field Service Manual**

25 July, 2010



---

# Important Safety Notices

## **WARNING**

- Never install telephone wiring during a lightning storm.
- Never install telephone jacks in wet locations unless the jack is specifically designed for wet locations.
- Never touch uninsulated telephone wires or terminals unless the telephone line has been disconnected at the network interface.
- Use caution when installing or modifying telephone lines.
- Avoid using a telephone (other than a cordless type) during an electrical storm. There may be a remote risk of electric shock from lightning.
- Do not use a telephone or cellular phone to report a gas leak in the vicinity of the leak.

## **CAUTION**

- Before installing the fax unit, switch off the main switch, and disconnect the power cord.
- The fax unit contains a lithium battery. The danger of explosion exists if a battery of this type is incorrectly replaced. Replace only with the same or an equivalent type recommended by the manufacturer. Discard batteries in accordance with the manufacturer's instructions and local regulations.

## **Note**

- **Note for Australia:**
- Unit must be connected to Telecommunication Network through a line cord that meets the requirements of ACA Technical Standard TS008.

---







# Symbols and Abbreviations

---

## Conventions Used in this Manual

---

This manual uses several symbols.

Symbol	What it means
	Refer to section number
	Screw
	Connector
	E-ring
	Clip ring
	Clamp

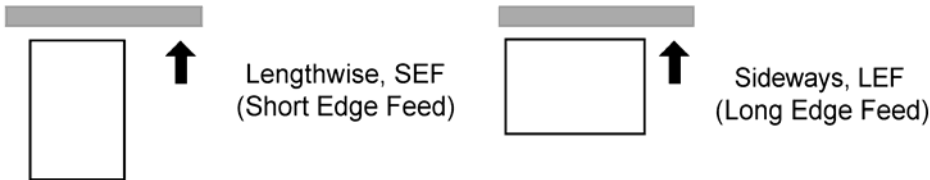

---

## Cautions, Notes, etc.

---

The following headings provide special information:

### **WARNING**

- Failure to obey warning information could result in serious injury or death.

### **CAUTION**

- Obey these guidelines to ensure safe operation and prevent minor injuries.

### **Important**

- Obey these guidelines to avoid problems such as misfeeds, damage to originals, loss of valuable data and to prevent damage to the machine.
- Always obey these guidelines to avoid serious problems such as misfeeds, damage to originals, loss of valuable data and to prevent damage to the machine. **bold** is added for emphasis.

---

**↓ Note**

- This document provides tips and advice about how to best service the machine.

# TABLE OF CONTENTS

---

Important Safety Notices.....	1
Symbols and Abbreviations.....	2
Conventions Used in this Manual.....	2
Cautions, Notes, etc.....	2

## 1. Installation Procedure

---

Fax Unit (D545).....	7
Component Check.....	7
Installation Procedure.....	8
Fax Unit Options.....	15
Memory Unit (G578).....	15
Handset (B433).....	16
G3 Interface Unit (D393).....	21
Component Check.....	21
Installation Procedure.....	22

## 2. Replacement and Adjustment

---

FCU.....	29
----------	----

## 3. Troubleshooting

---

Error Codes.....	31
IFAX Troubleshooting.....	49
IP-Fax Troubleshooting.....	51
IP-Fax Transmission.....	51
IP-Fax Reception.....	54

## 4. Service Table

---

Beforehand.....	57
Service Tables.....	58
SP1-XXX (Bit Switches).....	58
SP2-XXX (RAM Data).....	59
SP3-XXX (Tel Line Settings).....	60
SP4-XXX (ROM Versions).....	62
SP5-XXX (Initializing).....	62
SP6-XXX (Reports).....	63
SP7-XXX (Test Modes).....	65
Bit Switches.....	67

---

System Switches.....	67
I-Fax Switches.....	80
Printer Switches.....	86
Communication Switches.....	93
G3 Switches.....	102
G3-2 and G3-3 Switches.....	110
G4 Internal Switches.....	118
G4 Parameter Switches.....	118
IP Fax Switches.....	118
NCU Parameters.....	125
Dedicated Transmission Parameters.....	138
Programming Procedure.....	138
Parameters.....	138
Service RAM Addresses.....	146
<b>5. Specifications</b>	
General Specifications.....	157
FCU.....	157
Capabilities of Programmable Items.....	158
IFAX Specifications.....	160
IP-FAX Specifications.....	162
Fax Unit Configuration.....	163
<b>INDEX</b> .....	165





# 1. Installation Procedure

## Fax Unit (D545)

1

### Component Check

Check the quantity and condition of the components against the following list.

No.	Description	Q'ty
1	FCU I/F Board	1
2	FCU	1
3	FCU I/F Board Bracket	1
4	Support Bracket	1
5	Speaker	1
6	Modular Bracket	1
7	Handset Bracket (NA only)	2
8	Telephone Cable (NA only)	1
9	Multi-Language Decals	1 (Excluding NA)/ 2 (EU)
10	Harness: TEL and LINE	2
11	G3 Decal	1
12	Serial Number Decal	1
13	FCC Decal (NA only)	1
14	Ferrite Core	1 (EU) or 2 (NA)
15	Screw: M3x6	13
16	Clamp	3
17	Fax Key top	2
18	EMC Address Decal	1 (EU Only)
19	Quick Reference Fax Guide	1 (Excluding EU)

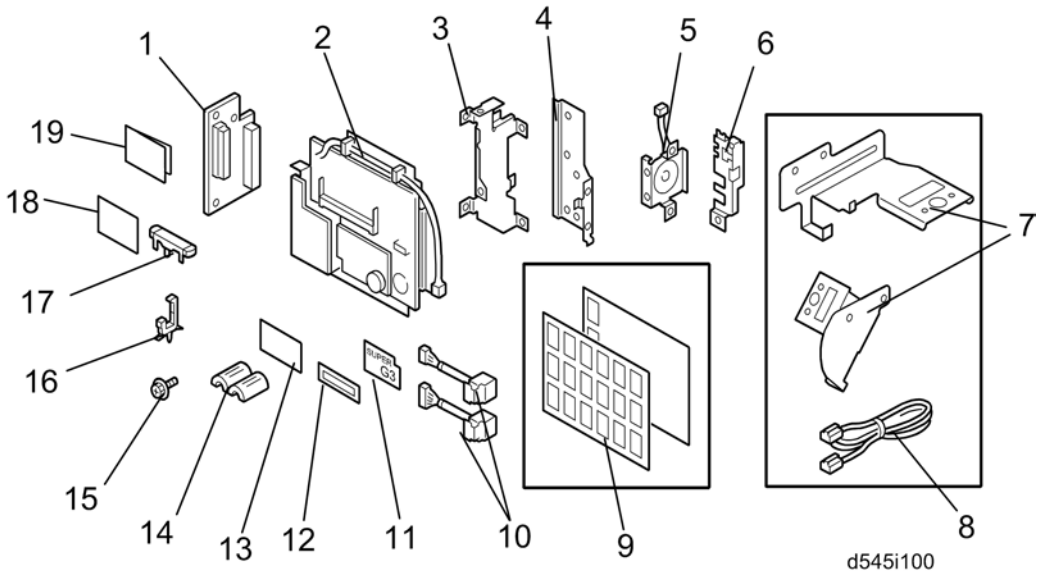



## Installation Procedure

### **⚠ CAUTION**

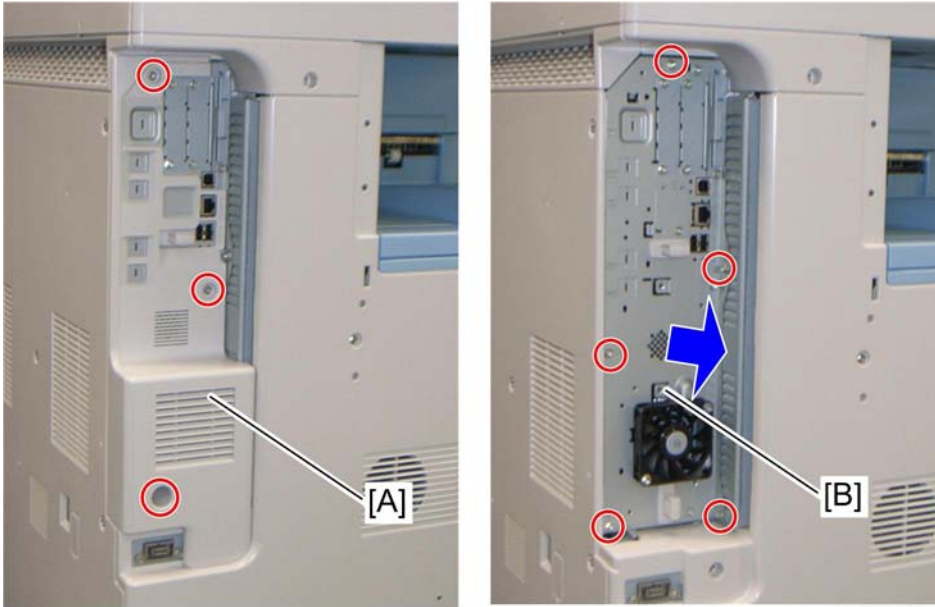
- Before installing this fax unit:
- Print out all data in the printer buffer.
- Turn off the main power switch and disconnect the power cord and the network cable.



d393i101

1. Remove the controller box cover [A] (  x 3).
2. Remove the controller box [B] (  x 5).

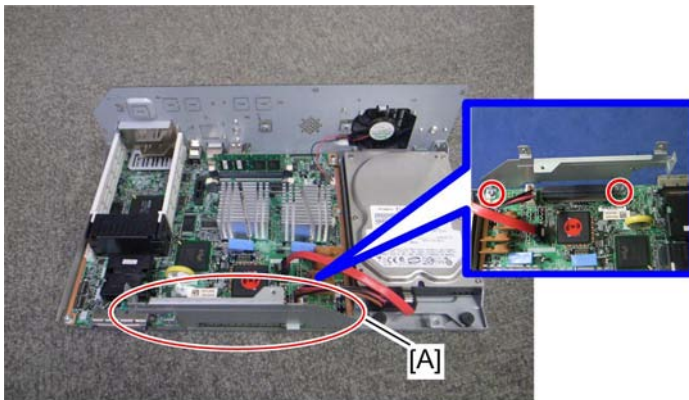

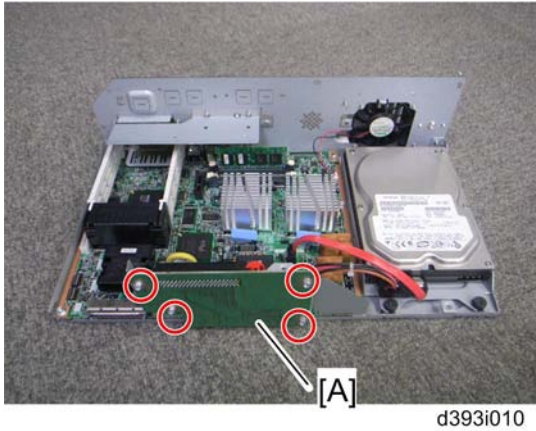

d393i008

3. Attach the FCU I/F board bracket [A] to the controller board (  x 2).

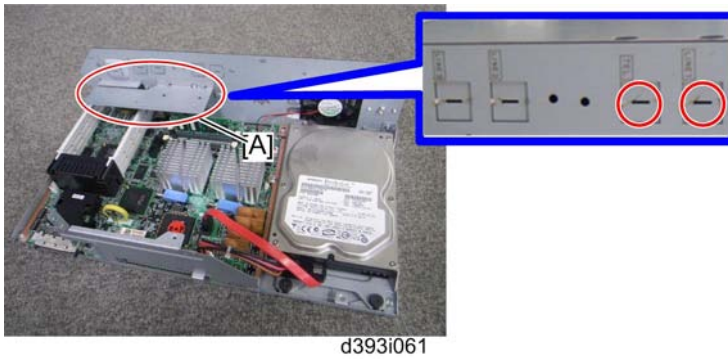

- 4. Attach the FCU I/F board [A] to the FCU I/F board bracket (  x 4).



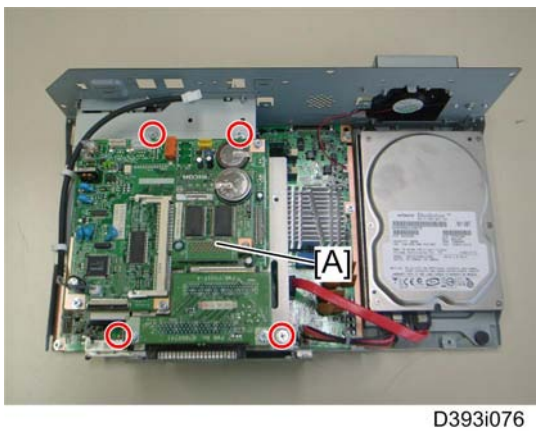

- 5. Attach the support bracket [A] to the controller box (  x 2).
- 6. Remove the "TEL" and "LINE1" covers with a screw driver.

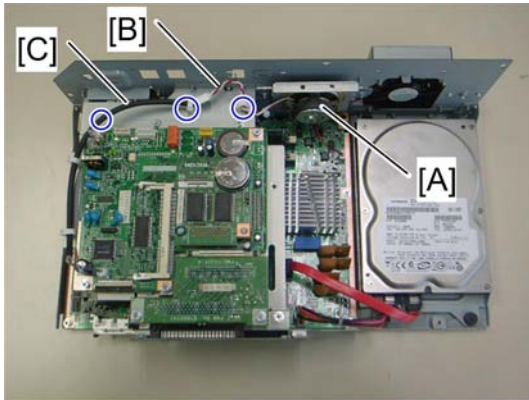

- 7. Install the FCU [A] to the controller board (  x 4).



d393i077

8. Install the speaker [A] to the controller box (  x 2) and connect the speaker cable [B] with the speaker relay cable [C] (  x 3).

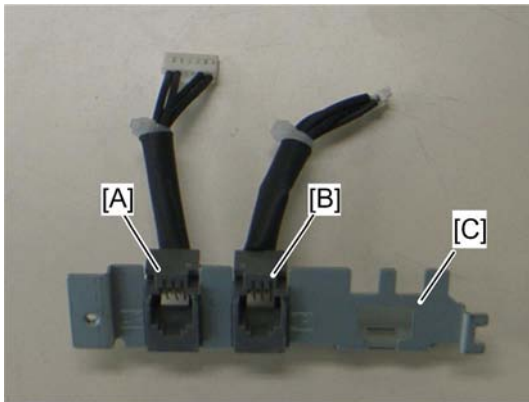

d393i094

9. Connect the two modular harnesses [A] (TEL), [B] (LINE1) to the modular bracket [C].

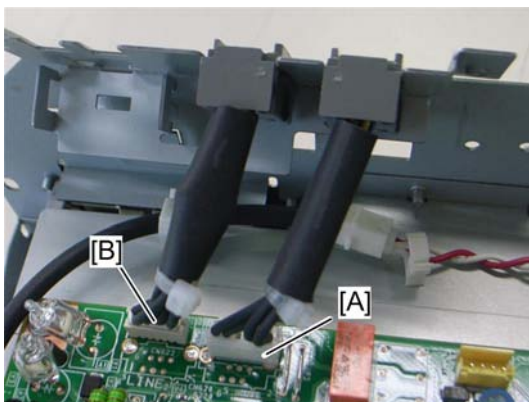

d393i095

10. Connect the two modular harnesses [A] (TEL), [B] (LINE1) to the FCU.

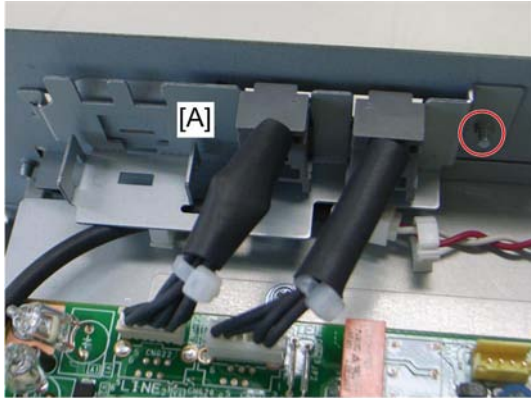

d393i096

11. Attach the modular bracket [A] to the controller box (  x 1).



d393i068

12. Switch the MBU battery jumper switch [A] to "ON" position.

**Note**

- Make sure that the MBU board is firmly connected to the FCU.

13. Reinstall the controller box.

14. Attach the handset support bracket and handset bracket to the copier, and then connect the handset cord with the ferrite core to the "TEL" jack if you install the handset to the machine.

**Note**

- For details, refer to the "Hand Set Installation" in the Service Manual for the Fax Unit (D545).

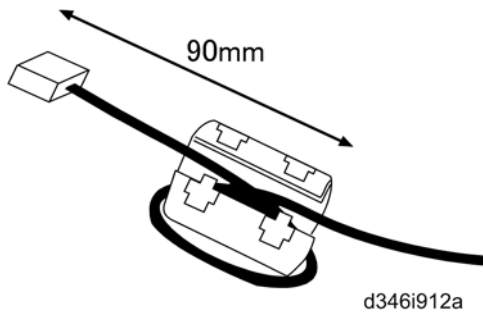

15. Attach the ferrite core to the telephone cord.
16. Connect the telephone cord to the "LINE 1" jack.

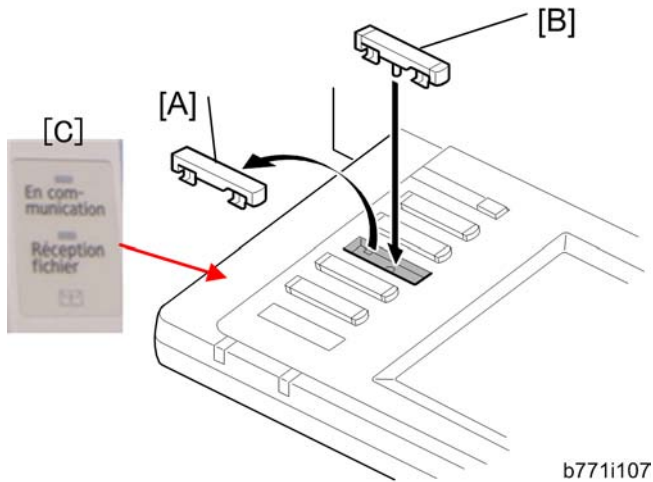

17. Replace bottom from the third key-slot cover [A] to the fax key [B].
18. Attach the Multi-Language Decals [C] (EU only).

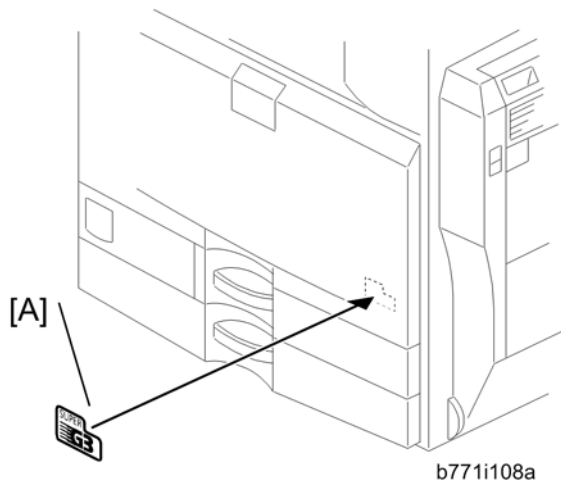

19. Attach the decal [A] (SUPER G3) to the front door.

20. Attach the serial number decal under the copier serial number decal on the rear cover of the machine.
21. Attach FCC decal on the rear cover of the machine (NA only).
22. Put the power plug into the outlet and turn on the main power of the machine.

**Note**

- Make sure that the outlet is grounded.
- "SRAM formatted" shows on the operation panel after you have turned the main switch on. Turn the main switch off and on again for normal use.

23. Make sure that the date and time are correctly set.



# Fax Unit Options

## Memory Unit (G578)

1

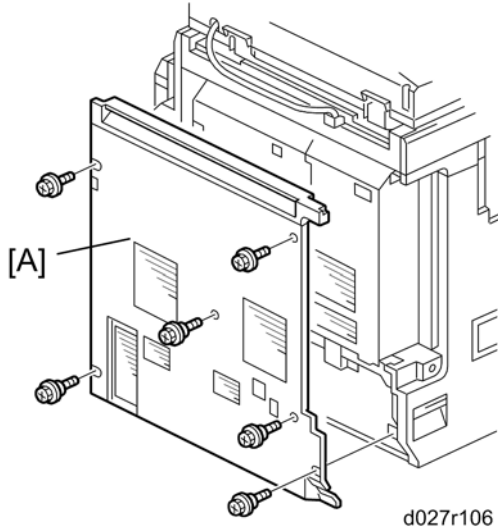

1. Rear cover [A] (  x 6)

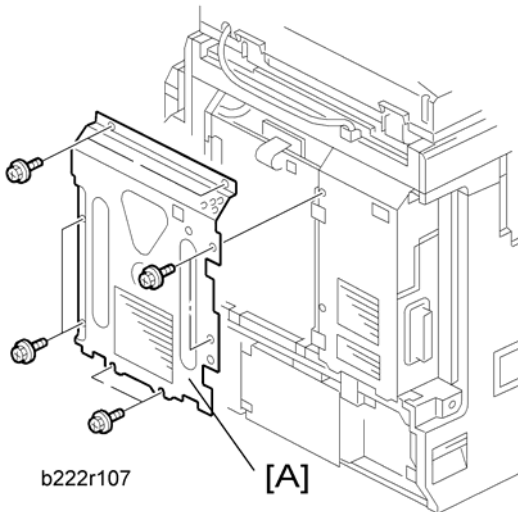

2. Controller box right cover [A] (  x 8)

1

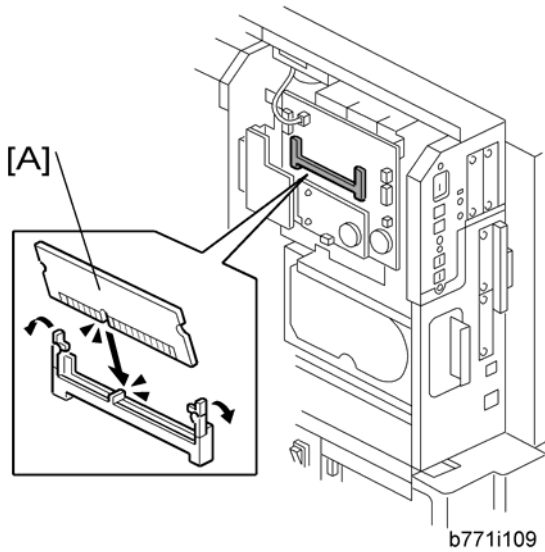

3. Install the memory option [A] on the FCU.
4. Re-assemble the machine

---

## Handset (B433)

---

### For D086/D087

---

#### ↓ Note

- The optional handset is available for the U.S. version only.

### For the copier without any finisher

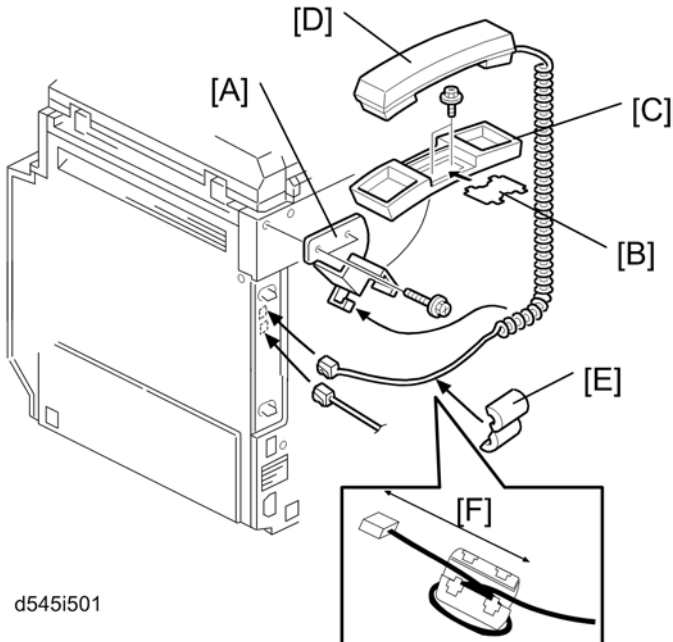

d545i501

1. Make two holes in the scanner left cover.
2. Attach the bracket [A] enclosed with the fax unit (  $\times 2$ : M3 x 12) as shown.
3. Remove the label [B] from the handset cradle [C]. Attach the cradle [C] to the bracket [A] (  $\times 2$ : M3 x 8), and then replace the label [B].
4. Install the handset [D] on the cradle [C].
5. Attach the ferrite core [E] to the cable. The length [F] must be 90 mm.
6. Attach the two clamps [G] as shown.
7. Line the cable [H] as shown (  $\times 2$ ).
8. Connect the cable [H] to the "TEL" jack at the rear of the machine.

### For the copier with a finisher

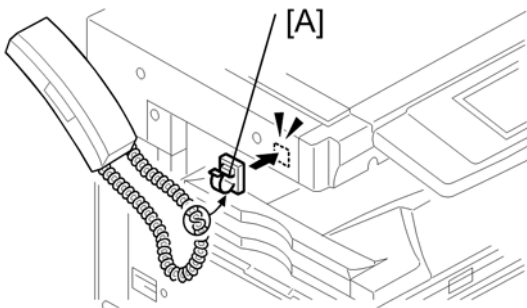

1. Do the handset installation procedure "for the copier without any finisher".
2. Attach the clamp [A] to the scanner left cover.
3. Clamp the handset cord with clamp [A].

### For D088/D089

---

**Note**

- The optional handset is available for the U.S. version only.



1. Remove the scanner left cover [A] (  x 2).

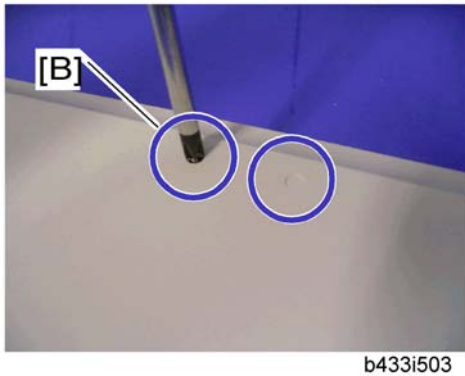

2. Make two holes in the scanner left cover.

**Note**

- Drill a hole from the outside of the cover with a screwdriver.

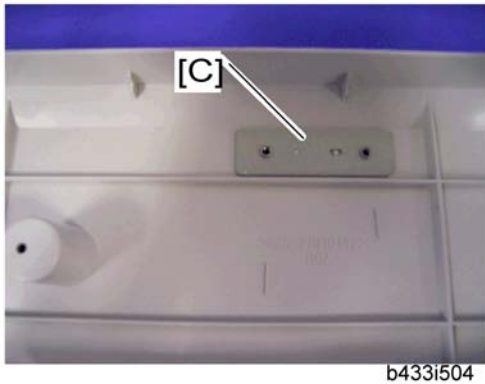

b433i504

3. Attach the handset support bracket [C] inside the scanner left cover.

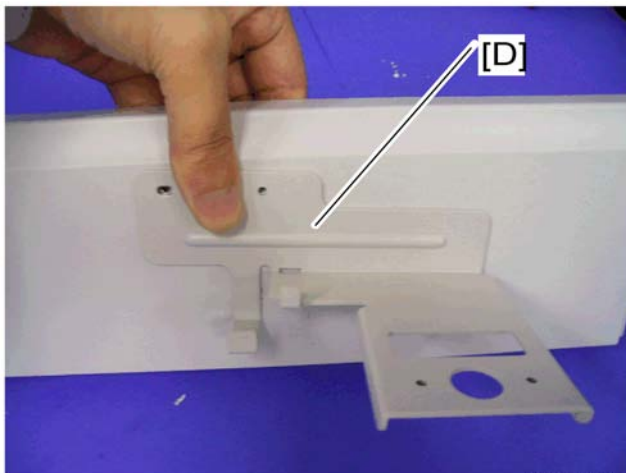

b433i505

4. Hold the handset bracket [D] and handset support bracket (set inside the scanner left cover).
5. Secure the handset bracket [D] (  x 2).

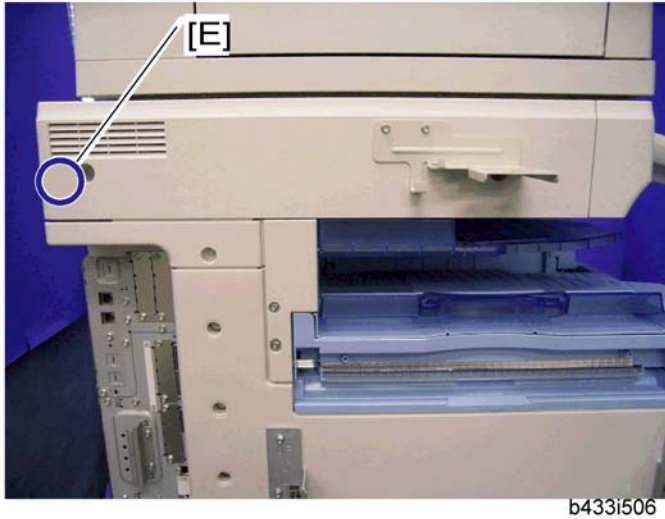

6. Install the scanner left cover on the machine.
7. Attach the clamp to the location [E].
8. Set the handset on the handset bracket.

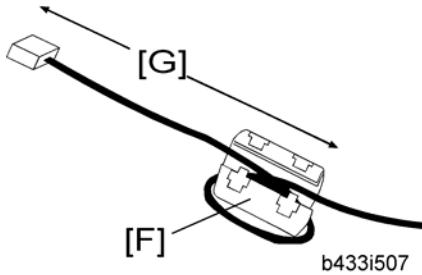

9. Put the ferrite core [F] on the handset cord as shown. The length [G] must be 90 mm.
10. Clamp the hand set cord.
11. Connect the handset cable to the "TEL" jack at the rear of the machine.

# G3 Interface Unit (D393)

## Component Check

1

Check the quantity and condition of the components against the following list.

No.	Description	Q'ty
1	SG3 Interface Unit	1
2	Modular Bracket for SG3	1
3	Clamp	2
4	Clamp	4
5	Screw: M3x6	6
6	Ferrite Core	1
7	Telephone Cable (NA only)	1
8	Flat Cable	1
9	Harness	1
10	EMC Address Decal (EU only)	1
11	FCC Decal (NA only)	1

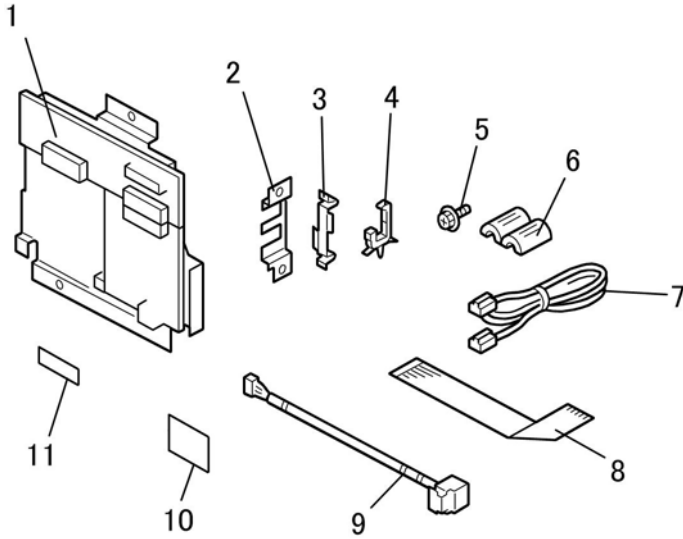

d393i200

---

## Installation Procedure

---

### CAUTION

- Before installing this optional unit:
- Print out all data in the printer buffer.
- Turn off the main switch and disconnect the power cord and the network cable.

You can add two more SG3 boards to this model. Follow the procedures for adding the single SG3 board installation or double SG3 boards installation as a customer needs.



## For Installing the single G3 Board

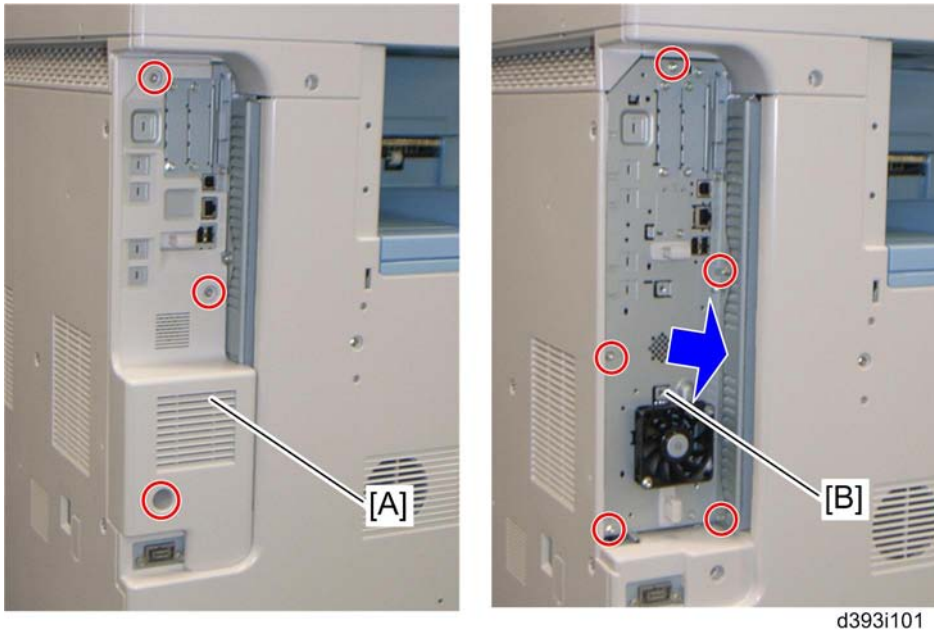

d393i101

1. Remove the controller box cover [A] (  $\times 3$  ).
2. Remove the controller box [B] (  $\times 5$  ).

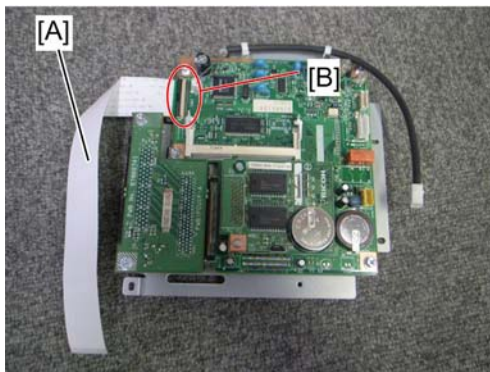

d393i011



d393i012

3. Attach one end (short length) of the flat cable [A] to the connector [B] of the FCU board.
4. Hold the flat cable with two clamps and pass the other end of the flat cable through the cutout as shown above.

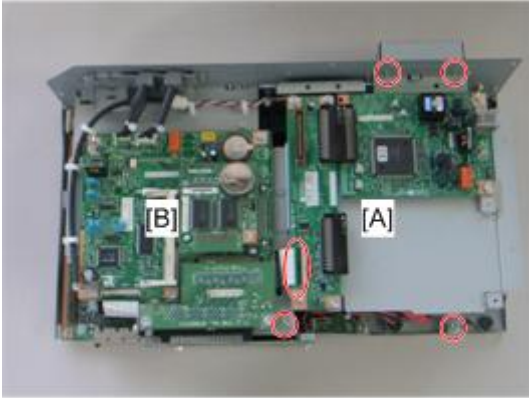

d393i081

5. Connect the SG3 interface unit [A] to the controller board [B] with the flat cable (4 x 4).

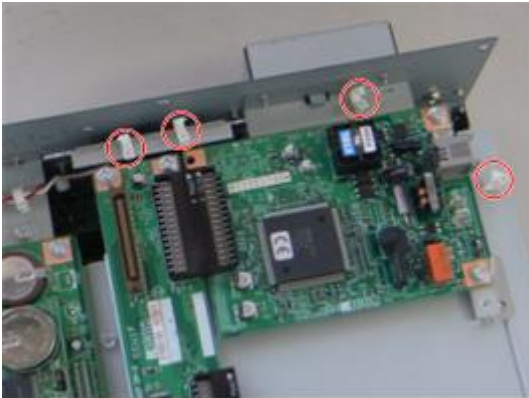

d393i048

6. Attach four clamps to the brackets.



d393i088C

7. Remove the "LINE2" cover with a screwdriver.

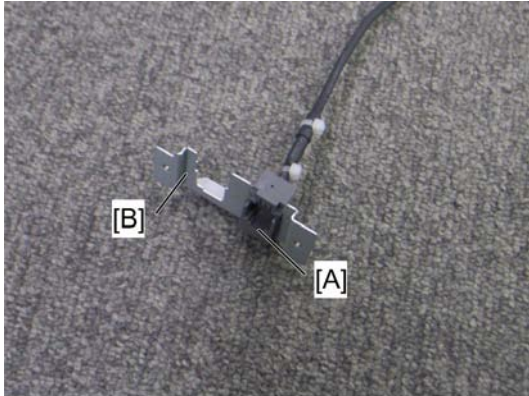

d393i047

8. Attach the socket of harness [A] (LINE2) to the modular bracket [B] for SG3.

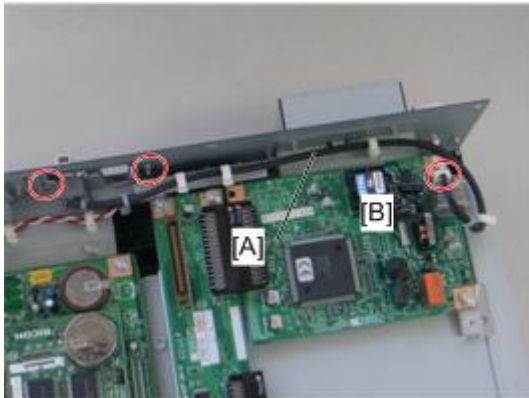

d393i091

9. Connect the harness [A] to the SG3 interface unit [B] (🔩 x 4).
10. Attach the modular bracket for SG3 to the controller box (🔩 x 2).
11. Reinstall the controller box.

## For Installing the Double G3 Boards

1



d393i090

1. Remove one of SG3 boards from the SG3 interface units and then attach the SG3 board to the other SG3 interface unit (  x 2).
2. Remove the controller box.

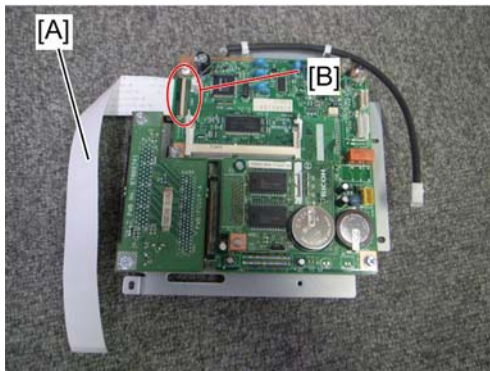

d393i011



d393i012

3. Attach one end (short length) of the flat cable [A] to the connector [B] of the FCU board.
4. Hold the flat cable with two clamps and pass the other end of the flat cable through the cutout as shown above.

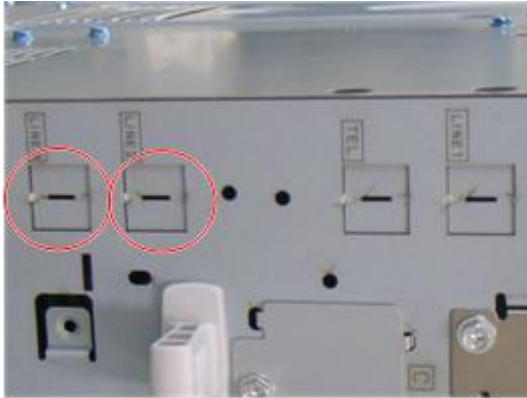

d393i088D

- Remove the "LINE2" cover and "LINE3" cover with a screwdriver.

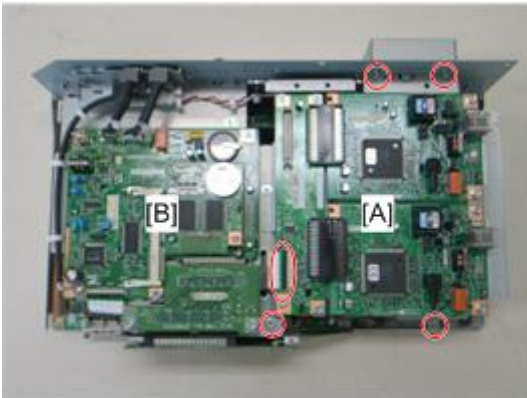

d393i081

- Connect the SG3 interface unit [A] to the controller board [B] with the flat cable (  x 4).

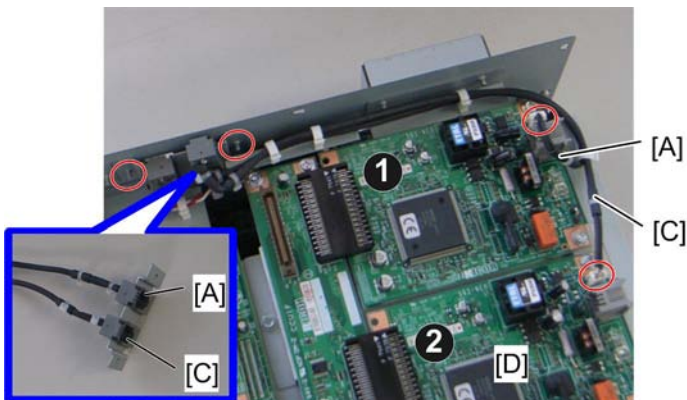

d393i092

- Attach the socket of harness [A] (LINE2) and the socket of harness [C] (LINE3) to the modular bracket for SG3.

8. Connect the harness [A] (LINE2) to the first SG3 board ❶ and the harness [C] (LINE3) to the second SG3 board ❷ (🔌 x 4).
9. Attach the modular bracket for SG3 to the controller box (🔧 x 2).
10. Reinstall the controller box.
11. Attach the ferrite core to the telephone cord for single SG3 board installation, or the two ferrite cores to the telephone cords for double-SG3 board installation.
12. Connect the telephone cord to the "LINE 2" jack for single SG3 board installation, or connect the telephone cords to the "LINE2" and "LINE3" jacks for double-SG3 board installation.
13. Connect the power plug to a power outlet and turn on the main power switch.
14. Enter the service mode. Set bit 1 of communication switch 16 to "1" (SP1-104-023).
15. Set bit 3 of communication switch 16 to "1" (SP1-104-023) if you have installed two SG3 boards.
16. Exit the service mode.
17. Turn the main power switch off and on.
18. Print out the system parameter list. Then check that "G3" shows as an option.
19. Set up and program the items required for PSTN-2 communications.

# 2. Replacement and Adjustment

---

## FCU

1. When you replace the FCU board, remove the MBU board from the old FCU board and install it on the new FCU board.
2. Set the correct date and time with the User Tools: User Tools > System Settings > Timer Setting > Set Date/Time.

 **Note**

- Do not turn off the battery switch (SW1).
- Do SP6101 to print the system parameters, and check the settings.





# 3. Troubleshooting

## Error Codes

If an error code occurs, retry the communication. If the same problem occurs, try to fix the problem as suggested below. Note that some error codes appear only in the error code display and on the service report.

Code	Meaning	Suggested Cause/Action
0-00	DIS/NSF not detected within 40 s of Start being pressed	<ul style="list-style-type: none"> <li>• Check the line connection.</li> <li>• The machine at the other end may be incompatible.</li> <li>• Replace the FCU.</li> <li>• Check for DIS/NSF with an oscilloscope.</li> <li>• If the rx signal is weak, there may be a bad line.</li> </ul>
0-01	DCN received unexpectedly	<ul style="list-style-type: none"> <li>• The other party is out of paper or has a jammed printer.</li> <li>• The other party pressed Stop during communication.</li> </ul>
0-03	Incompatible modem at the other end	The other terminal is incompatible.
0-04	CFR or FTT not received after modem training	<ul style="list-style-type: none"> <li>• Check the line connection.</li> <li>• Try changing the tx level and/or cable equalizer settings.</li> <li>• Replace the FCU.</li> <li>• The other terminal may be faulty; try sending to another machine.</li> <li>• If the rx signal is weak or defective, there may be a bad line.</li> </ul> <p><b>Cross reference</b></p> <p>Tx level - NCU Parameter 01 (PSTN)</p> <p>Cable equalizer - G3 Switch 07 (PSTN)</p> <p>Dedicated Tx parameters in Service Program Mode</p>
0-05	Modem training fails even G3 shifts down to 2400 bps.	<ul style="list-style-type: none"> <li>• Check the line connection.</li> <li>• Try adjusting the tx level and/or cable equalizer.</li> <li>• Replace the FCU.</li> <li>• Check for line problems.</li> </ul>

Code	Meaning	Suggested Cause/Action
		<p><b>Cross reference</b> See error code 0-04.</p>
0-06	The other terminal did not reply to DCS	<ul style="list-style-type: none"> <li>• Check the line connection.</li> <li>• Try adjusting the tx level and/or cable equalizer settings.</li> <li>• Replace the FCU.</li> <li>• The other end may be defective or incompatible; try sending to another machine.</li> <li>• Check for line problems.</li> </ul> <p><b>Cross reference</b> See error code 0-04.</p>
0-07	No post-message response from the other end after a page was sent	<ul style="list-style-type: none"> <li>• Check the line connection.</li> <li>• Replace the FCU.</li> <li>• The other end may have jammed or run out of paper.</li> <li>• The other end user may have disconnected the call.</li> <li>• Check for a bad line.</li> <li>• The other end may be defective; try sending to another machine.</li> </ul>
0-08	The other end sent RTN or PIN after receiving a page, because there were too many errors	<ul style="list-style-type: none"> <li>• Check the line connection.</li> <li>• Replace the FCU.</li> <li>• The other end may have jammed, or run out of paper or memory space.</li> <li>• Try adjusting the tx level and/or cable equalizer settings.</li> <li>• The other end may have a defective modem/FCU; try sending to another machine.</li> <li>• Check for line problems and noise.</li> </ul> <p><b>Cross reference</b></p> <ul style="list-style-type: none"> <li>• Tx level - NCU Parameter 01 (PSTN)</li> <li>• Cable equalizer - G3 Switch 07 (PSTN)</li> <li>• Dedicated Tx parameters in Service Program Mode</li> </ul>

Code	Meaning	Suggested Cause/Action
0-14	Non-standard post message response code received	<ul style="list-style-type: none"> <li>• Incompatible or defective remote terminal; try sending to another machine.</li> <li>• Noisy line: resend.</li> <li>• Try adjusting the tx level and/or cable equalizer settings.</li> <li>• Replace the FCU.</li> </ul> <p><b>Cross reference</b> See error code 0-08.</p>
0-15	The other terminal is not capable of specific functions.	<p>The other terminal is not capable of accepting the following functions, or the other terminal's memory is full.</p> <ul style="list-style-type: none"> <li>• Confidential rx</li> <li>• Transfer function</li> <li>• SEP/SUB/PWD/SID</li> </ul>
0-16	CFR or FTT not detected after modem training in confidential or transfer mode	<ul style="list-style-type: none"> <li>• Check the line connection.</li> <li>• Replace the FCU.</li> <li>• Try adjusting the tx level and/or cable equalizer settings.</li> <li>• The other end may have disconnected, or it may be defective; try calling another machine.</li> <li>• If the rx signal level is too low, there may be a line problem.</li> </ul> <p><b>Cross reference</b> See error code 0-08.</p>
0-20	Facsimile data not received within 6 s of retraining	<ul style="list-style-type: none"> <li>• Check the line connection.</li> <li>• Replace the FCU.</li> <li>• Check for line problems.</li> <li>• Try calling another fax machine.</li> <li>• Try adjusting the reconstruction time for the first line and/or rx cable equalizer setting.</li> </ul> <p><b>Cross reference</b> Reconstruction time - G3 Switch 0A, bit 6 Rx cable equalizer - G3 Switch 07 (PSTN)</p>

Code	Meaning	Suggested Cause/Action
0-21	EOL signal (end-of-line) from the other end not received within 5 s of the previous EOL signal	<ul style="list-style-type: none"> <li>• Check the connections between the FCU and line.</li> <li>• Check for line noise or other line problems.</li> <li>• Replace the FCU.</li> <li>• The remote machine may be defective or may have disconnected.</li> </ul> <p><b>Cross reference</b> Maximum interval between EOLs and between ECM frames - G3 Bit Switch 0A, bit 4</p>
0-22	The signal from the other end was interrupted for more than the acceptable modem carrier drop time (default: 200 ms)	<ul style="list-style-type: none"> <li>• Check the line connection.</li> <li>• Replace the FCU.</li> <li>• Defective remote terminal.</li> <li>• Check for line noise or other line problems.</li> <li>• Try adjusting the acceptable modem carrier drop time.</li> </ul> <p><b>Cross reference</b> Acceptable modem carrier drop time - G3 Switch 0A, bits 0 and 1</p>
0-23	Too many errors during reception	<ul style="list-style-type: none"> <li>• Check the line connection.</li> <li>• Replace the FCU.</li> <li>• Defective remote terminal</li> <li>• Check for line noise or other line problems.</li> <li>• Try asking the other end to adjust their tx level.</li> <li>• Try adjusting the rx cable equalizer setting and/or rx error criteria.</li> </ul> <p><b>Cross reference</b> Rx cable equalizer - G3 Switch 07 (PSTN) Rx error criteria - Communication Switch 02, bits 0 and 1</p>
0-30	The other terminal did not reply to NSS(A) in AI short protocol mode	<ul style="list-style-type: none"> <li>• Check the line connection.</li> <li>• Try adjusting the tx level and/or cable equalizer settings.</li> <li>• The other terminal may not be compatible.</li> </ul> <p><b>Cross reference</b> Dedicated tx parameters - Section 4</p>

Code	Meaning	Suggested Cause/Action
0-32	The other terminal sent a DCS, which contained functions that the receiving machine cannot handle.	<ul style="list-style-type: none"> <li>• Check the protocol dump list.</li> <li>• Ask the other party to contact the manufacturer.</li> </ul>
0-33	The data reception (not ECM) is not completed within 10 minutes.	<ul style="list-style-type: none"> <li>• Check the line connection.</li> <li>• The other terminal may have a defective modem/FCU.</li> </ul>
0-52	Polarity changed during communication	<ul style="list-style-type: none"> <li>• Check the line connection.</li> <li>• Retry communication.</li> </ul>
0-55	FCU does not detect the SG3.	<ul style="list-style-type: none"> <li>• FCU firmware or board defective.</li> <li>• SG3 firmware or board defective.</li> </ul>
0-56	The stored message data exceeds the capacity of the mailbox in the SG3.	<ul style="list-style-type: none"> <li>• SG3 firmware or board defective.</li> </ul>
0-70	The communication mode specified in CM/JM was not available (V.8 calling and called terminal)	<ul style="list-style-type: none"> <li>• The other terminal did not have a compatible communication mode (e.g., the other terminal was a V.34 data modem and not a fax modem.)</li> <li>• A polling tx file was not ready at the other terminal when polling rx was initiated from the calling terminal.</li> </ul>
0-74	The calling terminal fell back to T.30 mode, because it could not detect ANSam after sending CI.	<ul style="list-style-type: none"> <li>• The calling terminal could not detect ANSam due to noise, etc.</li> <li>• ANSam was too short to detect.</li> <li>• Check the line connection and condition.</li> <li>• Try making a call to another V.8/V.34 fax.</li> </ul>
0-75	The called terminal fell back to T.30 mode, because it could not detect a CM in response to ANSam (ANSam timeout).	<ul style="list-style-type: none"> <li>• The terminal could not detect ANSam.</li> <li>• Check the line connection and condition.</li> <li>• Try receiving a call from another V.8/V.34 fax.</li> </ul>
0-76	The calling terminal fell back to T.30 mode, because it could not detect a JM in response to CM (CM timeout).	<ul style="list-style-type: none"> <li>• The called terminal could not detect a CM due to noise, etc.</li> <li>• Check the line connection and condition.</li> <li>• Try making a call to another V.8/V.34 fax.</li> </ul>

Code	Meaning	Suggested Cause/Action
0-77	The called terminal fell back to T.30 mode, because it could not detect a CJ in response to JM (JM timeout).	<ul style="list-style-type: none"> <li>The calling terminal could not detect a JM due to noise, etc.</li> <li>A network that has narrow bandwidth cannot pass JM to the other end.</li> <li>Check the line connection and condition.</li> <li>Try receiving a call from another V.8/V.34 fax.</li> </ul>
0-79	The called terminal detected CI while waiting for a V.21 signal.	<ul style="list-style-type: none"> <li>Check for line noise or other line problems.</li> <li>If this error occurs, the called terminal falls back to T.30 mode.</li> </ul>
0-80	The line was disconnected due to a timeout in V.34 phase 2 – line probing.	<ul style="list-style-type: none"> <li>The guard timer expired while starting these phases. Serious noise, narrow bandwidth, or low signal level can cause these errors.</li> </ul>
0-81	The line was disconnected due to a timeout in V.34 phase 3 – equalizer training.	<p>If these errors happen at the transmitting terminal:</p> <ul style="list-style-type: none"> <li>Try making a call at a later time.</li> <li>Try using V.17 or a slower modem using dedicated tx parameters.</li> </ul>
0-82	The line was disconnected due to a timeout in the V.34 phase 4 – control channel start-up.	<ul style="list-style-type: none"> <li>Try increasing the tx level.</li> <li>Try adjusting the tx cable equalizer setting.</li> </ul>
0-83	The line was disconnected due to a timeout in the V.34 control channel restart sequence.	<p>If these errors happen at the receiving terminal:</p> <ul style="list-style-type: none"> <li>Try adjusting the rx cable equalizer setting.</li> <li>Try increasing the tx level.</li> <li>Try using V.17 or a slower modem if the same error is frequent when receiving from multiple senders.</li> </ul>
0-84	The line was disconnected due to abnormal signaling in V.34 phase 4 – control channel start-up.	<ul style="list-style-type: none"> <li>The signal did not stop within 10 s.</li> <li>Turn off the machine, then turn it back on.</li> <li>If the same error is frequent, replace the FCU.</li> </ul>
0-85	The line was disconnected due to abnormal signaling in V.34 control channel restart.	<ul style="list-style-type: none"> <li>The signal did not stop within 10 s.</li> <li>Turn off the machine, then turn it back on.</li> <li>If the same error is frequent, replace the FCU.</li> </ul>
0-86	The line was disconnected because the other terminal	<ul style="list-style-type: none"> <li>The other terminal was incompatible.</li> <li>Ask the other party to contact the manufacturer.</li> </ul>

Code	Meaning	Suggested Cause/Action
	requested a data rate using MPh that was not available in the currently selected symbol rate.	
0-87	The control channel started after an unsuccessful primary channel.	<ul style="list-style-type: none"> <li>The receiving terminal restarted the control channel because data reception in the primary channel was not successful.</li> <li>This does not result in an error communication.</li> </ul>
0-88	The line was disconnected because PPR was transmitted/ received 9 (default) times within the same ECM frame.	<ul style="list-style-type: none"> <li>Try using a lower data rate at the start.</li> <li>Try adjusting the cable equalizer setting.</li> </ul>
2-11	Only one V.21 connection flag was received	<ul style="list-style-type: none"> <li>Replace the FCU.</li> </ul>
2-12	Modem clock irregularity	<ul style="list-style-type: none"> <li>Replace the FCU.</li> </ul>
2-13	Modem initialization error	<ul style="list-style-type: none"> <li>Turn off the machine, then turn it back on.</li> <li>Update the modem ROM.</li> <li>Replace the FCU.</li> </ul>
2-23	JBIG compression or reconstruction error	<ul style="list-style-type: none"> <li>Turn off the machine, then turn it back on.</li> </ul>
2-24	JBIG ASIC error	<ul style="list-style-type: none"> <li>Turn off the machine, then turn it back on.</li> </ul>
2-25	JBIG data reconstruction error (BIH error)	<ul style="list-style-type: none"> <li>JBIG data error</li> <li>Check the sender's JBIG function.</li> <li>Update the MBU ROM.</li> </ul>
2-26	JBIG data reconstruction error (Float marker error)	
2-27	JBIG data reconstruction error (End marker error)	
2-28	JBIG data reconstruction error (Timeout)	
2-29	JBIG trailing edge maker error	<ul style="list-style-type: none"> <li>FCU defective</li> <li>Check the destination device.</li> </ul>

Code	Meaning	Suggested Cause/Action
2-50	The machine resets itself for a fatal FCU system error	<ul style="list-style-type: none"> <li>If this is frequent, update the ROM, or replace the FCU.</li> </ul>
2-51	The machine resets itself because of a fatal communication error	<ul style="list-style-type: none"> <li>If this is frequent, update the ROM, or replace the FCU.</li> </ul>
2-53	Snd msg() in the manual task is an error because the mailbox for the operation task is full.	<ul style="list-style-type: none"> <li>The user did the same operation many times, and this gave too much load to the machine.</li> </ul>
4-01	Line current was cut	<ul style="list-style-type: none"> <li>Check the line connector.</li> <li>Check for line problems.</li> <li>Replace the FCU.</li> </ul>
4-10	Communication failed because of an ID Code mismatch (Closed Network) or Tel. No./CSI mismatch (Protection against Wrong Connections)	<ul style="list-style-type: none"> <li>Get the ID Codes the same and/or the CSIs programmed correctly, then resend.</li> <li>The machine at the other end may be defective.</li> </ul>
5-10	DCR timer expired	<ul style="list-style-type: none"> <li>Replace the FCU.</li> </ul>
5-20	Storage impossible because of a lack of memory	<ul style="list-style-type: none"> <li>Temporary memory shortage.</li> <li>Test the SAF memory.</li> </ul>
5-21	Memory overflow	
5-23	Print data error when printing a substitute rx or confidential rx message	<ul style="list-style-type: none"> <li>Test the SAF memory.</li> <li>Ask the other end to resend the message.</li> </ul>
5-25	SAF file access error	<ul style="list-style-type: none"> <li>Replace an SD card or HDD.</li> <li>Replace the FCU.</li> </ul>
6-00	G3 ECM - T1 time out during reception of facsimile data	<ul style="list-style-type: none"> <li>Try adjusting the rx cable equalizer.</li> <li>Replace the FCU.</li> </ul>
6-01	G3 ECM - no V.21 signal was received	
6-02	G3 ECM - EOR was received	
6-04	G3 ECM - RTC not detected	<ul style="list-style-type: none"> <li>Check the line connection.</li> </ul>



Code	Meaning	Suggested Cause/Action
		<ul style="list-style-type: none"> <li>• Check for a bad line or defective remote terminal.</li> <li>• Replace the FCU.</li> </ul>
6-05	G3 ECM - facsimile data frame not received within 18 s of CFR, but there was no line fail	<ul style="list-style-type: none"> <li>• Check the line connection.</li> <li>• Check for a bad line or defective remote terminal.</li> <li>• Replace the FCU.</li> <li>• Try adjusting the rx cable equalizer</li> </ul> <p><b>Cross reference</b></p> <ul style="list-style-type: none"> <li>• Rx cable equalizer - G3 Switch 07 (PSTN)</li> </ul>
6-06	G3 ECM - coding/decoding error	<ul style="list-style-type: none"> <li>• Defective FCU.</li> <li>• The other terminal may be defective.</li> </ul>
6-08	G3 ECM - PIP/PIN received in reply to PPS.NULL	<ul style="list-style-type: none"> <li>• The other end pressed Stop during communication.</li> <li>• The other terminal may be defective.</li> </ul>
6-09	G3 ECM - ERR received	<ul style="list-style-type: none"> <li>• Check for a noisy line.</li> <li>• Adjust the tx levels of the communicating machines.</li> <li>• See code 6-05.</li> </ul>
6-10	G3 ECM - error frames still received at the other end after all communication attempts at 2400 bps	<ul style="list-style-type: none"> <li>• Check for line noise.</li> <li>• Adjust the tx level (use NCU parameter 01 or the dedicated tx parameter for that address).</li> <li>• Check the line connection.</li> <li>• Defective remote terminal.</li> </ul>
6-21	V.21 flag detected during high speed modem communication	<ul style="list-style-type: none"> <li>• The other terminal may be defective or incompatible.</li> </ul>
6-22	The machine resets the sequence because of an abnormal handshake in the V.34 control channel	<ul style="list-style-type: none"> <li>• Check for line noise.</li> <li>• If the same error occurs frequently, replace the FCU.</li> <li>• Defective remote terminal.</li> </ul>
6-99	V.21 signal not stopped within 6 s	<ul style="list-style-type: none"> <li>• Replace the FCU.</li> </ul>
13-17	SIP user name registration error	<ul style="list-style-type: none"> <li>• Double registration of the SIP user name.</li> <li>• Capacity for user-name registration in the SIP server is not sufficient.</li> </ul>

Code	Meaning	Suggested Cause/Action
13-18	SIP server access error	<ul style="list-style-type: none"> <li>• Incorrect initial setting for the SIP server.</li> <li>• Defective SIP server.</li> </ul>
13-24	SIP authentication error	<ul style="list-style-type: none"> <li>• Registered password in the device does not match the password in the SIP server.</li> </ul>
13-25	Network I/F setting error	<ul style="list-style-type: none"> <li>• IPV4 is not active in the active protocol setting.</li> <li>• IP address of the device is not registered.</li> </ul>
13-26	Network I/F setting error at power on	<ul style="list-style-type: none"> <li>• Active protocol setting does not match the I/F setting for SIP server.</li> <li>• IP address of the device is not registered.</li> </ul>
13-27	IP address setting error	<ul style="list-style-type: none"> <li>• IP address of the device is not registered.</li> </ul>
14-00	SMTP Send Error	<ul style="list-style-type: none"> <li>• Error occurred during sending to the SMTP server. Occurs for any error other than 14-01 to 16. For example, the mail address of the system administrator is not registered.</li> </ul>
14-01	SMTP Connection Failed	<ul style="list-style-type: none"> <li>• Failed to connect to the SMTP server (timeout) because the server could not be found.</li> <li>• The PC is not ready to transfer files.</li> <li>• SMTP server not functioning correctly.</li> <li>• The DNS IP address is not registered.</li> <li>• Network not operating correctly.</li> <li>• Destination folder selection not correct.</li> </ul>
14-02	No Service by SMTP Service (421)	<ul style="list-style-type: none"> <li>• SMTP server operating incorrectly, or the destination for direct SMTP sending is not correct.</li> <li>• Contact the system administrator and check that the SMTP server has the correct settings and operates correctly.</li> <li>• Contact the system administrator for direct SMTP sending and check the sending destination.</li> </ul>
14-03	Access to SMTP Server Denied (450)	<ul style="list-style-type: none"> <li>• Failed to access the SMTP server because the access is denied.</li> </ul>

Code	Meaning	Suggested Cause/Action
		<ul style="list-style-type: none"> <li>• SMTP server operating incorrectly. Contact the system administrator to determine if there is a problem with the SMTP server and to check that the SMTP server settings are correct.</li> <li>• Folder send destination is incorrect. Contact the system administrator to determine that the SMTP server settings and path to the server are correct.</li> <li>• Device settings incorrect. Confirm that the user name and password settings are correct.</li> <li>• Direct SMTP destination incorrect. Contact the system administrator to determine if there is a problem at the destination at that the settings at the destination are correct.</li> </ul>
14-04	Access to SMTP Server Denied (550)	<ul style="list-style-type: none"> <li>• SMTP server operating incorrectly</li> <li>• Direct SMTP sending not operating correctly</li> </ul>
14-05	SMTP Server HDD Full (452)	<ul style="list-style-type: none"> <li>• Failed to access the SMTP server because the HDD on the server is full.</li> <li>• Insufficient free space on the HDD of the SMTP server. Contact the system administrator and check the amount of space remaining on the SMTP server HDD.</li> <li>• Insufficient free space on the HDD where the destination folder is located. Contact the system administrator and check the amount of space remaining on the HDD where the target folder is located.</li> <li>• Insufficient free space on the HDD at the target destination for SMTP direct sending. Contact the system administrator and check the amount of space remaining on the target HDD.</li> </ul>
14-06	User Not Found on SMTP Server (551)	<ul style="list-style-type: none"> <li>• The designated user does not exist.</li> <li>• The designated user does not exist on the SMTP server.</li> <li>• The designated address is not for use with direct SMTP sending.</li> </ul>
14-07	Data Send to SMTP Server Failed (4XX)	<ul style="list-style-type: none"> <li>• Failed to access the SMTP server because the transmission failed.</li> <li>• PC not operating correctly.</li> </ul>

Code	Meaning	Suggested Cause/Action
		<ul style="list-style-type: none"> <li>• SMTP server operating incorrectly</li> <li>• Network not operating correctly.</li> <li>• Destination folder setting incorrect.</li> <li>• Direct SMTP sending not operating correctly.</li> </ul>
14-08	Data Send to SMTP Server Failed (5XX)	<ul style="list-style-type: none"> <li>• Failed to access the SMTP server because the transmission failed.</li> <li>• SMTP server operating incorrectly</li> <li>• Destination folder setting incorrect.</li> <li>• Direct SMTP sending not operating correctly.</li> <li>• Software application error.</li> </ul>
14-09	Authorization Failed for Sending to SMTP Server	<ul style="list-style-type: none"> <li>• POP-Before-SMTP or SMTP authorization failed.</li> <li>• Incorrect setting for file transfer</li> </ul>
14-10	Addresses Exceeded	<ul style="list-style-type: none"> <li>• Number of broadcast addresses exceeded the limit for the SMTP server.</li> </ul>
14-11	Buffer Full	<ul style="list-style-type: none"> <li>• The send buffer is full so the transmission could not be completed. Buffer is full due to using Scan-to-Email while the buffer is being used send mail at the same time.</li> </ul>
14-12	Data Size Too Large	<ul style="list-style-type: none"> <li>• Transmission was cancelled because the detected size of the file was too large.</li> </ul>
14-13	Send Cancelled	<ul style="list-style-type: none"> <li>• Processing is interrupted because the user pressed Stop.</li> </ul>
14-14	Security Locked File Error	<ul style="list-style-type: none"> <li>• Update the software because of the defective software.</li> </ul>
14-15	Mail Data Error	<ul style="list-style-type: none"> <li>• The transmitting a mail is interrupted via DCS due to the incorrect data.</li> <li>• Update the software because of the defective software.</li> </ul>
14-16	Maximum Division Number Error	<ul style="list-style-type: none"> <li>• When a mail is divided for the mail transmission and the division number of a mail are more than the specified number, the mail transmission is interrupted.</li> </ul>

Code	Meaning	Suggested Cause/Action
		<ul style="list-style-type: none"> <li>Update the software because of the defective software.</li> </ul>
14-17	Incorrect Ticket	<ul style="list-style-type: none"> <li>Update the software because of the defective software.</li> </ul>
14-18	Access to MCS File Error	<ul style="list-style-type: none"> <li>The access to MCS file is denied due to the no permission of access.</li> <li>Update the software because of the defective software.</li> </ul>
14-30	MCS File Creation Failed	<p>Failed to create the MCS file because:</p> <ul style="list-style-type: none"> <li>The number of files created with other applications on the Document Server has exceeded the limit.</li> <li>HDD is full or not operating correctly.</li> <li>Software error.</li> </ul>
14-31	UFS File Creation Failed	<p>UFS file could not be created:</p> <ul style="list-style-type: none"> <li>Not enough space in UFS area to handle both Scan-to-Email and IFAX transmission.</li> <li>HDD full or not operating correctly.</li> <li>Software error.</li> </ul>
14-32	Cancelled the Mail Due to Error Detected by NFAX	<ul style="list-style-type: none"> <li>Error detected with NFAX and send was cancelled due to a software error.</li> </ul>
14-33	No Mail Address For the Machine	<ul style="list-style-type: none"> <li>Neither the mail address of the machine nor the mail address of the network administrator is registered.</li> </ul>
14-34	Address designated in the domain for SMTP sending does not exist	<ul style="list-style-type: none"> <li>Operational error in normal mail sending or direct SMTP sending.</li> <li>Check the address selected in the address book for SMTP sending.</li> <li>Check the domain selection.</li> </ul>
14-50	Mail Job Task Error	<p>Due to an FCU mail job task error, the send was cancelled:</p> <ul style="list-style-type: none"> <li>Address book was being edited during creation of the notification mail.</li> <li>Software error.</li> </ul>

Code	Meaning	Suggested Cause/Action
14-51	UCS Destination Download Error	Not even one return notification can be downloaded: <ul style="list-style-type: none"> <li>The address book was being edited.</li> <li>The number for the specified destination does not exist (it was deleted or edited after the job was created).</li> </ul>
14-60	Send Cancel Failed	<ul style="list-style-type: none"> <li>The cancel operation by the user failed to cancel the send operation.</li> </ul>
14-61	Notification Mail Send Failed for All Destinations	<ul style="list-style-type: none"> <li>All addresses for return notification mail failed.</li> </ul>
14-62	Transmission Error due to the existence of zero line page	<ul style="list-style-type: none"> <li>When the 0 line page exists in received pages with G3 communication, the transmission is interrupted.</li> </ul>
15-01	POP3/IMAP4 Server Not Registered	<ul style="list-style-type: none"> <li>At startup, the system detected that the IP address of the POP3/IMAP4 server has not been registered in the machine.</li> </ul>
15-02	POP3/IMAP4 Mail Account Information Not Registered	<ul style="list-style-type: none"> <li>The POP3/IMAP4 mail account has not been registered.</li> </ul>
15-03	Mail Address Not Registered	<ul style="list-style-type: none"> <li>The mail address has not been registered.</li> </ul>
15-10	DCS Mail Receive Error	<ul style="list-style-type: none"> <li>Error other than 15-11 to 15-18.</li> </ul>
15-11	Connection Error	The DNS or POP3/IMAP4 server could not be found: <ul style="list-style-type: none"> <li>The IP address for DNS or POP3/IMAP4 server is not stored in the machine.</li> <li>The DNS IP address is not registered.</li> <li>Network not operating correctly.</li> </ul>
15-12	Authorization Error	POP3/IMAP4 send authorization failed: <ul style="list-style-type: none"> <li>Incorrect IFAX user name or password.</li> <li>Access was attempted by another device, such as the PC.</li> <li>POP3/IMAP4 settings incorrect.</li> </ul>
15-13	Receive Buffer Full	<ul style="list-style-type: none"> <li>Occurs only during manual reception. Transmission cannot be received due to insufficient buffer space. The buffer is being used for mail send or Scan-to-Email.</li> </ul>

Code	Meaning	Suggested Cause/Action
15-14	Mail Header Format Error	<ul style="list-style-type: none"> <li>The mail header is not standard format. For example, the Date line description is incorrect.</li> </ul>
15-15	Mail Divide Error	<ul style="list-style-type: none"> <li>The e-mail is not in standard format. There is no boundary between parts of the e-mail, including the header.</li> </ul>
15-16	Mail Size Receive Error	<ul style="list-style-type: none"> <li>The mail cannot be received because it is too large.</li> </ul>
15-17	Receive Timeout	<ul style="list-style-type: none"> <li>May occur during manual receiving only because the network is not operating correctly.</li> </ul>
15-18	Incomplete Mail Received	<ul style="list-style-type: none"> <li>Only one portion of the mail was received.</li> </ul>
15-31	Final Destination for Transfer Request Reception Format Error	<ul style="list-style-type: none"> <li>The format of the final destination for the transfer request was incorrect.</li> </ul>
15-39	Send/Delivery Destination Error	<p>The transmission cannot be delivered to the final destination:</p> <ul style="list-style-type: none"> <li>Destination file format is incorrect.</li> <li>Could not create the destination for the file transmission.</li> </ul>
15-41	SMTP Receive Error	<ul style="list-style-type: none"> <li>Reception rejected because the transaction exceeded the limit for the "Auth. E-mail RX" setting.</li> </ul>
15-42	Off Ramp Gateway Error	<ul style="list-style-type: none"> <li>The delivery destination address was specified with Off Ramp Gateway OFF.</li> </ul>
15-43	Address Format Error	<ul style="list-style-type: none"> <li>Format error in the address of the Off Ramp Gateway.</li> </ul>
15-44	Addresses Over	<ul style="list-style-type: none"> <li>The number of addresses for the Off Ramp Gateway exceeded the limit of 30.</li> </ul>
15-61	Attachment File Format Error	<ul style="list-style-type: none"> <li>The attached file is not TIFF format.</li> </ul>
15-62	TIFF File Compatibility Error	<p>Could not receive transmission due to:</p> <ul style="list-style-type: none"> <li>Resolution error</li> <li>Image of resolution greater than 200 dpi without extended memory.</li> <li>Resolution is not supported.</li> <li>Page size error</li> <li>The page size was larger than A3.</li> <li>Compression error</li> </ul>

Code	Meaning	Suggested Cause/Action
		<ul style="list-style-type: none"> <li>File was compressed with other than MH, MR, or MMR.</li> </ul>
15-63	TIFF Parameter Error	<p>The TIFF file sent as the attachment could not be received because the TIFF header is incorrect:</p> <ul style="list-style-type: none"> <li>The TIFF file attachment is a type not supported.</li> <li>The TIFF file attachment is corrupted.</li> <li>Software error.</li> </ul>
15-64	TIFF Decompression Error	<p>The file received as an attachment caused the TIFF decompression error:</p> <ul style="list-style-type: none"> <li>The TIFF format of the attachment is corrupted.</li> <li>Software error.</li> </ul>
15-71	Not Binary Image Data	<ul style="list-style-type: none"> <li>The file could not be received because the attachment was not binary image data.</li> </ul>
15-73	MDN Status Error	<ul style="list-style-type: none"> <li>Could not find the Disposition line in the header of the Return Receipt, or there is a problem with the firmware.</li> </ul>
15-74	MDN Message ID Error	<ul style="list-style-type: none"> <li>Could not find the Original Message ID line in the header of the Return Receipt, or there is a problem with the firmware.</li> </ul>
15-80	Mail Job Task Read Error	<ul style="list-style-type: none"> <li>Could not receive the transmission because the destination buffer is full and the destination could not be created (this error may occur when receiving a transfer request or a request for notification of reception).</li> </ul>
15-81	Repeated Destination Registration Error	<ul style="list-style-type: none"> <li>Could not repeat receive the transmission because the destination buffer is full and the destination could not be created (this error may occur when receiving a transfer request or a request for notification of reception).</li> </ul>
15-91	Send Registration Error	<p>Could not receive the file for transfer to the final destination:</p> <ul style="list-style-type: none"> <li>The format of the final destination or the transfer destination is incorrect.</li> <li>Destinations are full so the final and transfer destinations could not be created.</li> </ul>



Code	Meaning	Suggested Cause/Action
15-92	Memory Overflow	<ul style="list-style-type: none"> <li>Transmission could not be received because memory overflowed during the transaction.</li> </ul>
15-93	Memory Access Error	<ul style="list-style-type: none"> <li>Transaction could not complete due to a malfunction of SAF memory.</li> </ul>
15-94	Incorrect ID Code	<ul style="list-style-type: none"> <li>The machine rejected an incoming e-mail for transfer request, because the ID code in the incoming e-mail did not match the ID code registered in the machine.</li> </ul>
15-95	Transfer Station Function	<ul style="list-style-type: none"> <li>The machine rejected an incoming e-mail for transfer because the transfer function was unavailable.</li> </ul>
22-00	Original length exceeded the maximum scan length	<ul style="list-style-type: none"> <li>Divide the original into more than one page.</li> <li>Check the resolution used for scanning. Lower the scan resolution if possible.</li> <li>Add optional page memory.</li> </ul>
22-01	Memory overflow while receiving	<ul style="list-style-type: none"> <li>Wait for the files in the queue to be sent.</li> <li>Delete unnecessary files from memory.</li> <li>Transfer the substitute reception files to an another fax machine, if the machine's printer is busy or out of order.</li> <li>Add an optional SAF memory card or hard disk.</li> </ul>
22-02	Tx or rx job stalled due to line disconnection at the other end	<ul style="list-style-type: none"> <li>The job started normally but did not finish normally; data may or may not have been received fully.</li> <li>Restart the machine.</li> </ul>
22-04	The machine cannot store received data in the SAF	<ul style="list-style-type: none"> <li>Update the ROM</li> <li>Replace the FCU.</li> </ul>
22-05	No G3 parameter confirmation answer	<ul style="list-style-type: none"> <li>Defective FCU board or firmware.</li> </ul>
23-00	Data read timeout during construction	<ul style="list-style-type: none"> <li>Restart the machine.</li> <li>Replace the FCU.</li> </ul>
25-00	The machine software resets itself after a fatal transmission error occurred	<ul style="list-style-type: none"> <li>Update the ROM</li> <li>Replace the FCU.</li> </ul>
F0-xx	V.34 modem error	<ul style="list-style-type: none"> <li>Replace the FCU.</li> </ul>

Code	Meaning	Suggested Cause/Action
F6-xx	SG3 modem error	<ul style="list-style-type: none"><li>• Update the SG3 modem ROM.</li><li>• Replace the SG3 board.</li><li>• Check for line noise or other line problems.</li><li>• Try communicating another V.8/V.34 fax.</li></ul>

# IFAX Troubleshooting

Use the following procedures to determine whether the machine or another part of the network is causing the problem.

Communication Route	Item	Action [Remarks]
General LAN	1. Connection with the LAN	<ul style="list-style-type: none"> <li>• Check that the LAN cable is connected to the machine.</li> <li>• Check that the LEDs on the hub are lit.</li> </ul>
	2. LAN activity	Check that other devices connected to the LAN can communicate through the LAN.
Between IFAX and PC	1. Network settings on the PC	<ul style="list-style-type: none"> <li>• Check the network settings on the PC.</li> </ul> <p>[Is the IP address registered in the TCP/IP properties in the network setup correct? Check the IP address with the administrator of the network.]</p>
	2. Check that PC can connect with the machine	<ul style="list-style-type: none"> <li>• Use the "ping" command on the PC to contact the machine.</li> </ul> <p>[At the MS-DOS prompt, type ping then the IP address of the machine, then press Enter.]</p>
	3. LAN settings in the machine	<ul style="list-style-type: none"> <li>• Check the LAN parameters</li> <li>• Check if there is an IP address conflict with other PCs.</li> </ul> <p>[Use the "Network" function in the User Tools. If there is an IP address conflict, inform the administrator.]</p>
Between machine and e-mail server	1. LAN settings in the machine	<ul style="list-style-type: none"> <li>• Check the LAN parameters</li> <li>• Check if there is an IP address conflict with other PCs.</li> </ul> <p>[Use the "Network" function in the User Tools. If there is an IP address conflict, inform the administrator.]</p>
	2. E-mail account on the server	<ul style="list-style-type: none"> <li>• Make sure that the machine can log into the e-mail server.</li> </ul>

Communication Route	Item	Action [Remarks]
		<ul style="list-style-type: none"> <li>Check that the account and password stored in the server are the same as in the machine.</li> </ul> [Ask the administrator to check.]
	3. E-mail server	<ul style="list-style-type: none"> <li>Make sure that the client devices which have an account in the server can send/receive e-mail.</li> </ul> [Ask the administrator to check. Send a test e-mail with the machine's own number as the destination. The machine receives the returned e-mail if the communication is performed successfully.]
Between e-mail server and internet	1. E-mail account on the Server	<ul style="list-style-type: none"> <li>Make sure that the PC can log into the e-mail server.</li> <li>Check that the account and password stored in the server are the same as in the machine.</li> </ul> [Ask the administrator to check.]
	2. E-mail server	<ul style="list-style-type: none"> <li>Make sure that the client devices which have an account in the server can send/receive e-mail.</li> </ul> [Ask the administrator to check. Send a test e-mail with the machine's own number as the destination. The machine receives the returned e-mail if the communication is performed successfully.]
	3. Destination e-mail address	<ul style="list-style-type: none"> <li>Make sure that the e-mail address is actually used.</li> <li>Check that the e-mail address contains no incorrect characters such as spaces.</li> </ul>
	4. Router settings	<ul style="list-style-type: none"> <li>Use the "ping" command to contact the router.</li> <li>Check that other devices connected to the router can sent data over the router.</li> </ul> [Ask the administrator of the server to check.]
	5. Error message by e-mail from the network of the destination.	<ul style="list-style-type: none"> <li>Check whether e-mail can be sent to another address on the same network, using the application e-mail software.</li> <li>Check the error e-mail message.</li> </ul> [Inform the administrator of the LAN.]

# IP-Fax Troubleshooting

## IP-Fax Transmission

### Cannot send by IP Address/Host Name

Check Point		Action
1	LAN cable connected?	Check the LAN cable connection.
2	Specified IP address/host name correct?	Check the IP address/host name.
3	Firewall/NAT is installed?	Cannot breach the firewall. Send by using another method (Fax, Internet Fax)
4	Transmission sent manually?	Manual sending not supported.
5	IP address of local machine registered?	Register the IP address.
6	Remote terminal port number setting other than 1720?	Send by specifying the port number.
7	Specified port number correct?	Confirm the port number of the remote fax.
8	DNS server registered when host name specified?	Contact the network administrator.
9	Remote fax a T.38 terminal?	Check whether the remote fax is a T38 terminal.
10	Remote fax switched off or busy?	Check that the remote fax is switched on.
11	Network bandwidth too narrow?	Request the network administrator to increase the bandwidth.
		Raise the delay level. IPFAX SW 01 Bit 0 to 3
		IP-Fax bandwidth is the same as the DCS speed. Set IP-Fax SW00 Bit 6 to 1.
12	Remote fax cancelled transmission?	Check whether the remote fax cancelled the transmission.

### Cannot send via VoIP Gateway

Check Point		Action
1	LAN cable connected?	Check the LAN cable connection.
2	VoIP Gateway T.38 standard?	Contact the network administrator.
3	VoIP Gateway installed correctly?	Contact the network administrator.
4	VoIP Gateway power switched on?	Contact the network administrator.
5	Is the IP address/host name of the specified Gateway correct?	Check the IP address/host name.
6	Number of the specified fax correct?	Check the remote fax number.
7	Firewall/NAT is installed?	Cannot breach the firewall. Send by using another method (Fax, Internet Fax)
8	Transmission sent manually?	Manual sending not supported.
9	IP address of local fax registered?	Register the IP address.
10	DNS registered when host name specified?	Contact the network administrator.
11	Remote fax a G3 fax?	Check that the remote fax is a G3 fax.
12	G3 fax is connected to VoIP gateway?	Check that G3 fax is connected.
13	Remote G3 fax turned on?	Check that G3 fax is switched on.
14	Network bandwidth too narrow?	Request the network administrator to increase the bandwidth.
		Raise the network delay level. IPFAX SW 01 Bit 0 to 3
		IP-Fax bandwidth is the same as the DCS speed. Set IP-Fax SW00 Bit 6 to 1.

### Cannot send by Alias Fax number.

Check Point		Action
1	LAN cable connected?	Check the LAN cable connection.

2	Number of specified Alias fax correct?	Confirm the Alias of the remote fax. Error Code: 13-14
3	Firewall/NAT installed?	Cannot breach the firewall. Send by using another method (Fax, Internet Fax)
4	Transmission sent manually?	Manual sending not supported.
5	Gatekeeper installed correctly?	Contact the network administrator.
6	Gatekeeper power switched on?	Contact the network administrator.
7	IP address/host name of Gatekeeper correct?	Check the IP address/host name.
8	DNS server registered when Gatekeeper host name specified?	Contact the network administrator.
9	Enable H.323 SW is set to on?	Check the settings. See User Parameter SW 34 Bit 0
10	IP address of local fax registered?	Register the IP address of the local fax.
11	Alias number of local fax registered?	Register the Alias number of the local fax.
12	Remote fax registered in Gatekeeper?	Contact the network administrator.
13	Remote fax a T.38 terminal?	Check whether the remote fax is a T38 terminal.
14	Remote fax switched off or busy?	Contact the network administrator.
15	Network bandwidth too narrow?	Request the system administrator to increase the bandwidth.
		Raise the delay level. IPFAX SW 01 Bit 0 to 3
		Lower the modem transmission baud rate. IPFAX SW 05
16	Remote fax cancelled transmission?	Check whether the remote fax cancelled the transmission.

## IP-Fax Reception

### Cannot receive via IP Address/Host Name.

Check Point		Action
1	LAN cable connected?	Check the LAN cable connection.
2	Firewall/NAT is installed?	Cannot breach the firewall. Send by using another method (Fax, Internet Fax)
3	IP address of local fax registered?	Register the IP address.
4	Port number specified at remote sender fax (if required)?	Request the sender to specify the port number.
5	Specified port number correct (if required)?	Request the sender to check the port number.
6	DNS server registered when host name specified on sender side?	<p>Contact the network administrator.</p> <p><b>Note</b></p> <ul style="list-style-type: none"> <li>The sender machine displays this error code if the sender fax is a Ricoh model.</li> </ul>
7	Network bandwidth too narrow?	Request the system administrator to increase the bandwidth.
		<p>Lower the start modem reception baud rate on the receiving side.</p> <p>IPFAX SW06</p>
8	Remote fax cancelled transmission?	Check whether the remote fax cancelled the transmission.



### Cannot receive by VoIP Gateway.

Check Point		Action
1	LAN cable connected?	Check the LAN cable connection.
2	Firewall/NAT is installed?	Cannot breach the firewall. Request the remote fax to send by using another method (Fax, Internet Fax)



3	VoIP Gateway installed correctly?	Contact the network administrator.
4	VoIP Gateway power switched on?	Contact the network administrator.
5	IP address/host name of specified VoIP Gateway correct on sender's side?	Request the remote fax to check the IP address/host name.
6	DNS server registered when host name specified on sender side?	Contact the network administrator.
7	Network bandwidth too narrow?	Request the network administrator to increase the bandwidth.
8	G3 fax connected?	Check that G3 fax is connected.
9	G3 fax power switched on?	Check that G3 fax is switched on.

### Cannot receive by Alias Fax number.

	Check Point	Action
1	LAN cable connected?	Check the LAN cable connection.
2	Firewall/NAT is installed?	Cannot the breach firewall. Request the remote fax to send by using another method (Fax, Internet Fax)
3	Gatekeeper installed correctly?	Contact the network administrator.  <b>Note</b> <ul style="list-style-type: none"> <li>The sender machine displays this error code when the sender fax is a Ricoh model.</li> </ul>
4	Power to Gatekeeper switched on?	Contact the network administrator.  <b>Note</b> <ul style="list-style-type: none"> <li>The sender machine displays this error code when the sender fax is a Ricoh model.</li> </ul>
5	IP address/host name of Gatekeeper correct on the sender's side?	Request the sender to check the IP address/host name.  <b>Note</b> <ul style="list-style-type: none"> <li>The sender machine displays this error code when the sender fax is a Ricoh model.</li> </ul>

6	DNS server registered when Gatekeeper host name specified on sender's side?	<p>Contact the network administrator.</p> <p><b>Note</b></p> <ul style="list-style-type: none"> <li>The sender machine displays this error code when the sender fax is a Ricoh model.</li> </ul>
7	Enable H.323 SW is set to on?	<p>Request the sender to check the settings.</p> <p>User Parameter SW 34 Bit 0</p> <p><b>Note</b></p> <ul style="list-style-type: none"> <li>Only if the remote sender fax is a Ricoh fax.</li> </ul>
8	Local fax IP address registered?	Register the IP address.
9	Local fax Alias number registered?	Register the Alias number.
10	Network bandwidth too narrow?	Request the system administrator to increase the bandwidth.
		<p>Lower the start modem reception baud rate on the receiving side.</p> <p>IPFAX SW06</p>
11	Remote fax cancelled transmission?	Check whether the remote fax cancelled the transmission.
12	Local fax registered in Gatekeeper?	<p>Contact the network administrator.</p> <p><b>Note</b></p> <ul style="list-style-type: none"> <li>The sender machine displays this error code when the sender fax is a Ricoh model.</li> </ul>

# 4. Service Table

---

## Beforehand

### CAUTION

- Never turn off the main power switch when the power LED is lit or flashing. To avoid damaging the hard disk or memory, press the operation power switch to switch the power off, wait for the power LED to go off, and then switch the main power switch off.







### Note

- The main power LED (🔆) lights or flashes while the platen cover or ARDF is open, while the main machine is communicating with a facsimile or the network server, or while the machine is accessing the hard disk or memory for reading or writing data.

# Service Tables

## SP1-XXX (Bit Switches)

### Bit Switches

1	Mode No.	Function
101	System Switch	
	001 – 032	00 – 1F Change the bit switches for system settings for the fax option  "Bit Switches"
102	Ifax Switch	
	001 – 016	00 – 0F Change the bit switches for internet fax settings for the fax option  "Bit Switches"
103	Printer Switch	
	001 – 016	00 – 0F Change the bit switches for printer settings for the fax option  "Bit Switches"
104	Communication Switch	
	001 – 032	00 – 1F Change the bit switches for communication settings for the fax option  "Bit Switches"
105	G3-1 Switch	
	001 – 016	00 – 0F Change the bit switches for the protocol settings of the standard G3 board  "Bit Switches"
106	G3-2 Switch	
	001 – 016	00 – 0F Change the bit switches for the protocol settings of the optional G3 board  "Bit Switches"
107	G3-3 Switch	

	001 – 016	00 – 0F	Change the bit switches for the protocol settings of the optional G3 board 🔑 "Bit Switches"
108	G4 Internal Switch		
	001 – 032	00 – 1F	<b>Not used</b> (Do not change the bit switches)
109	G4 Parameter Switch		
	001 – 016	00 – 0F	<b>Not used</b> (Do not change the bit switches)
111	IP fax Switch		
	001 – 016	00 – 0F	Change the bit switches for optional IP fax parameters 🔑 "Bit Switches"

## SP2-XXX (RAM Data)

2	Mode No.		Function
101	RAM Read/Write		
	001		Change RAM data for the fax board directly. 🔑 "Service RAM Addresses"
102	Memory Dump		
	001	G3-1 Memory Dump	Print out RAM data for the fax board. 🔑 "Service RAM Addresses"
	002	G3-2 Memory Dump	Print out RAM data for the optional SG3 board.
	003	G3-3 Memory Dump	Print out RAM data for the optional SG3 board.
	004	G4 Memory Dump	Not used
103	G3-1 NCU Parameters		
	001 – 023	CC, 01 – 22	NCU parameter settings for the standard G3 board. 🔑 "NCU Parameters"
104	G3-2 NCU Parameters		
	001 – 023	CC, 01 – 22	NCU parameter settings for the optional G3 board. 🔑 "NCU Parameters"

105	G3-3 NCU Parameters		
	001 – 023	CC, 01 – 22	NCU parameter settings for the optional G3 board. 🔑 "NCU Parameters"

### SP3-XXX (Tel Line Settings)

3	Mode No.		Function
101	Service Station		
	001	Fax Number	Enter the fax number of the service station.
	002	Select Line	Select the line type.
102	Serial Number		
	000		Enter the fax unit's serial number.
103	PSTN-1 Port Settings		
	001	Select Line	Select the line type setting for the G3-1 line. If the machine is installed on a PABX line, select "PABX", "PABX(GND)" or "PABX(FLASH)".
	002	PSTN Access Number	Enter the PSTN access number for the G3-1 line.
	003	Memory Lock Disabled	Not used
104	PSTN-2 Port Settings		
	001	Select Line	Select the line setting for the G3-2 line. If the machine is installed on a PABX line, select "PABX", "PABX(GND)" or "PABX(FLASH)".
	002	PSTN Access Number	Enter the PSTN access number for the G3-2 line.
	003	Memory Lock Disabled	Not used
	004	Transmission Disabled	If you turn this SP on, the machine does not send any fax messages on the G3-2 line.

105	PSTN-3 Port Settings		
	001	Select Line	Select the line setting for the G3-3 line. If the machine is installed on a PABX line, select "PABX", "PABX(GND)" or "PABX(FLASH)".
	002	PSTN Access Number	Enter the PSTN access number for the G3-3 line.
	003	Memory Lock Disabled	Not used
	004	Transmission Disabled	If you turn this SP on, the machine does not send any fax messages on the G3-3 line.
106	ISDN Port Settings		
	001	Select Line	<b>Not used</b> (Do not change the settings.)
	002	PSTN Access Number	
	003	Memory Lock Disabled	
106	004	Transmission Disabled	
107	IPFAX Port Settings		
	001	H323 Port	Sets the H323 port number.
	002	SIP Port	Sets the SIP port number.
	003	RAS Port	Sets the RAS port number.
	004	Gatekeeper port	Sets the Gatekeeper port number.
	005	T.38 Port	Sets the T.38 port number.
	006	SIP Server Port	Sets the SIP port number.
007	IPFAX Protocol Priority	Select "H323" or "SIP".	
201	FAX SW		
	001 – 032	00 – 1F	

### SP4-XXX (ROM Versions)

4	Mode No.		Function
101	001	FCU ROM Version	Displays the FCU ROM version.
102	001	Error Codes	Displays the latest 64 fax error codes.
103	001	G3-1 ROM Version	Displays the G3-1 modem version.
104	001	G3-2 ROM Version	Displays the G3-2 modem version.
105	001	G3-3 ROM Version	Displays the G3-3 modem version.
106	001	G4 ROM Version	<b>Not used</b> (Do not change the settings.)
107	001	Charge ROM Version	<b>Not used</b> (Do not change the settings.)

### SP5-XXX (Initializing)

5	Mode No.	Function
101	Initialize SRAM	
	000	Initializes the bit switches and user parameters, user data in the SRAM, files in the SAF memory, and clock.
102	Erase All Files	
	000	Erases all files stored in the SAF memory.
103	Reset Bit Switches	
	000	Resets the bit switches and user parameters.
104	Factory setting	
	000	Resets the bit switches and user parameters, user data in the SRAM and files in the SAF memory.
105	Initialize All Bit Switches	
	000	Initializes all the current bit switch settings.
106	Initialize Security Bit Switches	



	000	Initializes only the security bit switches. If you select automatic output/display for the user parameter switches, the security settings are initialized.
--	-----	--

## SP6-XXX (Reports)

6	Mode No.		Function
101	System Parameter List		
	000	-	Touch the "ON" button to print the system parameter list.
102	Service Monitor Report		
	000	-	Touch the "ON" button to print the service monitor report.
103	G3 Protocol Dump List		
	001	G3 All Communications	Prints the protocol dump list of all communications for all G3 lines.
	002	G3-1 (All Communications)	Prints the protocol dump list of all communications for the G3-1 line.
	003	G3-1 (1 Communication)	Prints the protocol dump list of the last communication for the G3-1 line.
	004	G3-2 (All Communications)	Prints the protocol dump list of all communications for the G3-2 line.
	005	G3-2 (1 Communication)	Prints the protocol dump list of the last communication for the G3-2 line.
	006	G3-3 (All Communications)	Prints the protocol dump list of all communications for the G3-3 line.
	007	G3-3 (1 Communication)	Prints the protocol dump list of the last communication for the G3-3 line.
104	G4 Protocol Dump List		
	001	Dch + Bch 1	<b>Not used</b> (Do not change the settings.)

	002	Dch		
	003	Bch 1 Link Layer		
	004	Dch Link Layer		
	005	Dch +Bch 2		
	006	Bch 2 Link Layer		
105	All Files print out		<p>Prints out all the user files in the SAF memory, including confidential messages.</p> <p><b>Note</b></p> <ul style="list-style-type: none"> <li>Do not use this function, unless the customer is having trouble printing confidential messages or recovering files stored using the memory lock feature.</li> </ul>	
	000	-		
106	Journal Print out			
	001	All Journals		The machine prints all the communication records on the report.
	002	Specified Date		The machine prints all communication records after the specified date.
107	Log List Print out		These log print out functions are for designer use only.	
	001	All log files		
	002	Printer		
	003	SC/TRAP Stored		
	004	Decompression		
	005	Scanner		
	006	JOB/SAF		
	007	Reconstruction		
	008	JBIG		
	009	Fax Driver		

	010	G3CCU	
	011	Fax Job	
	012	CCU	
	013	Scanner Condition	
108	IP Protocol Dump List		
	001	All Communications	Prints the protocol dump list of all communications for the IP fax line.
	002	1 Communication	Prints the protocol dump list of the last communication for the IP fax line.

## SP7-XXX (Test Modes)

These are the test modes for PTT approval.

7	Function
101	G3-1 Modem Tests
102	G3-1 DTMF Tests
103	Ringer Test
104	G3-1 V34 (S2400baud)
105	G3-1 V34 (S2800baud)
106	G3-1 V34 (S3000baud)
107	G3-1 V34 (S3200baud)
108	G3-1 V34 (S3429baud)
109	Recorded Message Test
110	G3-2 Modem Tests
111	G3-2 DTMF Tests
112	G3-2 V34 (S2400baud)
113	G3-2 V34 (S2800baud)

114	G3-2 V34 (S3000baud)
115	G3-2 V34 (S3200baud)
116	G3-2 V34 (S3429baud)
117	G3-3 Modem Tests
118	G3-3 DTMF Tests
119	G3-3 V34 (S2400baud)
120	G3-3 V34 (S2800baud)
121	G3-3 V34 (S3000baud)
122	G3-3 V34 (S3200baud)
123	G3-3 V34 (S3429baud)
124	IG3-1 Modem Tests - <b>Not used</b>
125	IG3-1 DTMF Tests - <b>Not used</b>
126	IG3-1 V34 (S2400baud) - <b>Not used</b>
127	IG3-1 V34 (S2800baud) - <b>Not used</b>
128	IG3-1 V34 (S3000baud) - <b>Not used</b>
129	IG3-1 V34 (S3200baud) - <b>Not used</b>
130	IG3-1 V34 (S3429baud) - <b>Not used</b>
131	IG3-2 Modem Tests - <b>Not used</b>
132	IG3-2 DTMF Tests - <b>Not used</b>
133	IG3-2 V34 (S2400baud) - <b>Not used</b>
134	IG3-2 V34 (S2800baud) - <b>Not used</b>
135	IG3-2 V34 (S3000baud) - <b>Not used</b>
136	IG3-2 V34 (S3200baud) - <b>Not used</b>
137	IG3-2 V34 (S3429baud) - <b>Not used</b>

# Bit Switches

## ↓ Note

- Do not adjust a bit switch or use a setting that is described as "Not used", as this may cause the machine to malfunction or to operate in a manner that is not accepted by local regulations. Such bits are for use only in other areas, such as Japan.

Default settings for bit switches are not listed in this manual. Refer to the System Parameter List printed by the machine.

## System Switches

4

System Switch 00 (SP No. 1-101-001)		
No	Function	Comments
0	Dedicated transmission parameter programming 0: Disabled 1: Enabled	Set this bit to 1 before changing any dedicated transmission parameters.  This setting is automatically reset to "0" after turning off and on.
1	Not used	Do not change
2	Technical data printout on the Journal 0: Disabled 1: Enabled	1: Instead of the personal name, the following data are listed on the Journal for each G3 communication.
	<p>Example:</p> <p><b>0000 32V34 288/264 L0100 03 04</b>            (1) (2)(3) (4) (5) (6) (7) (8)</p> <p>(1): EQM value (Line quality data). A larger number means more errors.            (2): Symbol rate (V.34 only)            (3): Final modem type used            (4): Starting data rate (for example, 288 means 28.8 kbps)            (5): Final data rate            (6): Rx level (see below for how to read the rx level)            (7): Total number of error lines that occurred during non-ECM reception.            (8): Total number of burst error lines that occurred during non-ECM reception.</p>	

	<p><b>Note</b></p> <ul style="list-style-type: none"> <li>EQM and rx level are fixed at "FFFF" in tx mode.</li> <li>The seventh and eighth numbers are fixed at "00" for transmission records and ECM reception records.</li> </ul>	
	<p>Rx level calculation</p> <p>Example:</p> <p><b>0000 32V34 288/264 L0100 03 04</b>                  (1) (2)(3) (4) (5) (6) (7) (8)</p> <p>The four-digit hexadecimal value (N) after "L" indicates the rx level.</p> <p>The <b>high</b> byte is given first, followed by the <b>low</b> byte. Divide the decimal value of N by -16 to get the rx level.</p> <p>In the above example, the decimal value of N (= 0100 [H]) is 256.</p> <p>So, the actual rx level is <math>256 / -16 = -16</math> dB</p>	
3	Not used	Do not change this setting.
4	Line error mark print 0: OFF, 1: ON (print)	When "1" is selected, a line error mark is printed on the printout if a line error occurs during reception. This shows an error position in ECM off mode.
5	G3/G4 communication parameter display 0: Disabled 1: Enabled	This is a fault-finding aid. The LCD shows the key parameters (see "G3 Communication Parameters" below this table). This is normally disabled because it cancels the CSI display for the user.  Be sure to reset this bit to "0" after testing.
6	Protocol dump list output after each communication 0: Off 1: On	This is only used for communication troubleshooting. It shows the content of the transmitted facsimile protocol signals. Always reset this bit to 0 after finishing testing.  If system switch 09 bit 6 is at "1", the list is only printed if there was an error during the communication.
7	Not used	Do not change the setting.

**G3 Communication Parameters**

Modem rate	336: 33600 bps 168: 16800 bps 312: 31200 bps 144: 14400 bps 288: 28800 bps 120: 12000 bps
------------	---

	264: 26400 bps 96: 9600 bps 240: 24000 bps 72: 7200 bps 216: 21600 bps 48: 4800 bps 192: 19200 bps 24: 2400 bps
Resolution	S: Standard (8 x 3.85 dots/mm) D: Detail (8 x 7.7 dots/mm) F: Fine (8 x 15.4 dots/mm) SF: Superfine (16 x 15.4 dots/mm) 21: Standard (200 x 100 dpi) 22: Detail (200 x 200 dpi) 44: Superfine (400 x 400 dpi)
Compression mode	MMR: MMR compression MR: MR compression MH: MH compression JBO: JBIG compression (Optional mode) JBB: JBIG compression (Basic mode)
Communication mode	ECM: With ECM NML: With no ECM
Width and reduction	A4: A4 (8.3"), no reduction B4: B4 (10.1"), no reduction A3: A3 (11.7"), no reduction
I/O rate	0: 0 ms/line 5: 5 ms/line 10: 10 ms/line 20: 20 ms/line 25: 2.5 ms/line 40: 40 ms/line <div style="border: 1px solid blue; border-radius: 10px; padding: 2px; display: inline-block; margin-top: 10px;">  <b>Note</b> </div> <ul style="list-style-type: none"> <li>• "40" is displayed while receiving a fax message using AI short protocol.</li> </ul>

**System Switch 01** - Not used (Do not change the factory settings.)

System Switch 02 (SP No. 1-101-003)				
No	Function		Comments	
0	Not used		Do not change these settings.	
2	Forced reset after transmission stalls 0: Off 1: On		With this setting on, the machine resets itself automatically if a transmission stalls and fails to complete the job.	
3	Not used		Do not change these settings.	
4	File retention time 0: Depends on User Parameter 24 [18(H)] 1: No limit		1: A file that had a communication error will not be erased unless the communication is successful.	
5	Not used		Do not change this setting.	
6-7	Memory read/write by RDS		(0,0): All RDS systems are always locked out. (0,1), (1,0): Normally, RDS systems are locked out, but the user can temporarily switch RDS on to allow RDS operations to take place. RDS will automatically be locked out again after a certain time, which is stored in System Switch 03. Note that if an RDS operation takes place, RDS will not switch off until this time limit has expired. (1,1): At any time, an RDS system can access the machine.	
	Bit 7	Bit 6		Setting
	0	0		Always disabled
	0	1		User selectable
	1	0		User selectable
	1	1		Always enabled

System Switch 03 (SP No. 1-101-004)		
No	Function	Comments
0 to 7	Length of time that RDS is temporarily switched on when bits 6 and 7 of System Switch 02 are set to "User selectable"	00 - 99 hours (BCD). This setting is only valid if bits 6 and 7 of System Switch 02 are set to "User selectable". The default setting is 24 hours.

System Switch 04 (SP No. 1-101-005)		
No	Function	Comments



0-2	Not used	Do not change these settings.
3	Printing dedicated tx parameters on Quick/Speed Dial Lists 0: Disabled 1: Enabled	1: Each Quick/Speed dial number on the list is printed with the dedicated tx parameters (10 bytes each). The first 10 bytes of data are the programmed dedicated tx parameters; 34 bytes of data are printed (the other 24 bytes have no use for service technicians).
4-7	Not used	Do not change these settings.

**System Switch 05** - Not used (Do not change the factory settings.)

#### System Switch 06 (SP No. 1-101-007)

No	Function	Comments
0 to 7	Margin setting for Create Margin Transmission	71 to 99 (BCD) %. This setting determines the reduction ratio when the user uses the Create Margin Transmission feature. Default setting: 1001 0011 (93%)

**System Switch 07** - Not used (Do not change the factory settings.)

**System Switch 08** - Not used (Do not change the factory settings.)

#### System Switch 09 (SP No. 1-101-010)

No	Function	Comments
0	Addition of image data from confidential transmissions on the transmission result report 0: Disabled 1: Enabled	If this feature is enabled, the top half of the first page of confidential messages will be printed on transmission result reports.
1	Print timing of communication reports on the Journal when no image data was exchanged. 0: After DCS/NSS communication (default), 1: After polling	0: Journal is printed only when image data is sent. 1: Journal is printed when any data is sent.
2	Automatic error report printout	0: Error reports will not be printed.

	0: Disabled 1: Enabled	1: Error reports will be printed automatically after failed communications.
3	Printing of the error code on the error report 0: No 1: Yes	1: Error codes are printed on the error reports. This can be used for detecting an error which rarely occurs.
4	Not used	Do not change this setting.
5	Power failure report 0: Disabled 1: Enabled (default)	1: A power failure report will be automatically printed after the power is switched on if a fax message disappeared from the memory when the power was turned off last. <b>NOTE:</b> If "0" is selected, no reports are printed and no one may recognize that fax data is gone due to a power failure.
6	Conditions for printing the protocol dump list 0: Print for all communications 1: Print only when there is a communication error	This switch becomes effective only when system switch 00 bit 6 is set to 1. 1: Set this bit to 1 when you wish to print a protocol dump list only for communications with errors. <b>NOTE:</b> The memory size is limited. Use this bit switch only when some log reports are necessary.
7	Priority given to various types of remote terminal ID when printing reports 0: RTI > CSI > Dial label > Tel. number 1: Dial label > Tel. number > RTI > CSI	This bit determines which set of priorities the machine uses when listing remote terminal names on reports. Dial Label: The name stored, by the user, for the Quick/Speed Dial number.

System Switch 0A (SP No. 1-101-011)		
No	Function	Comments
0	Automatic port selection 0: Disabled, 1: Enabled	When "1" is selected, a suitable port is automatically selected if the selected port is not used. <b>NOTE:</b> This bit is useful if all communication lines at a customer site are not same quality.
1-2	Not used	Do not change these settings.

3	Continuous polling reception 0: Disabled 1: Enabled	This feature allows a series of stations to be polled in a continuous cycle. This will continue until the polling reception file is erased.  The dialing interval is the same as memory transmission.
4	Dialing on the ten-key pad when the external telephone is off-hook 0: Disabled 1: Enabled	0: Prevents dialing from the ten-key pad while the external telephone is off-hook. Use this setting when the external telephone is not by the machine, or if a wireless telephone is connected as an external telephone.  1: The user can dial on the machine's ten-key pad when the handset is off-hook.
5	On hook dial 0: Disabled 1: Enabled	0: On hook dial is disabled.
6-7	Not used	Do not change the factory settings

**System Switch OB** - Not used (Do not change the factory settings.)

**System Switch OC** - Not used (Do not change the factory settings.)

**System Switch OD** - Not used (Do not change the factory settings.)

#### System Switch OE (SP No. 1-101-015)

No	Function	Comments
0-1	Not used	Do not change the settings.
2	Enable/disable for direct sending selection 0: Direct sending off 1: Direct sending on	Direct sending cannot operate when the capture function is on during sending. Setting this switch to "1" enables direct sending without capture.  Setting this switch to "0" masks the direct sending function on the operation panel so direct sending with ScanRouter cannot be selected.
3	Action when the external handset goes off-hook 0: Manual tx and rx operation 1: Memory tx and rx operation (the display remains the same)	0: Manual tx is possible while the external handset is off-hook. However, manual tx during handset off-hook may not be sent to a correct direction. Manual tx is not possible.  1: The display stays in standby mode even when the external handset is used, so that other people can use

		the machine for memory tx operation. Note that manual tx and rx are not possible with this setting.
4-7	Not used	Do not change these settings.

System Switch 0F (SP No. 1-101-016)			
No	Function	Comments	
0 to 7	Country/area code for functional settings (Hex)	This country/area code determines the factory settings of bit switches and RAM addresses. However, it has no effect on the NCU parameter settings and communication parameter RAM addresses.  Cross reference NCU country code: SP No. 2-103-001 for G3-1 SP No. 2-104-001 for G3-2 SP No. 2-105-001 for G3-3	
	00: France		11: USA
	01: Germany		12: Asia
	02: UK		13: Japan
	03: Italy		14: Hong Kong
	04: Austria		15: South Africa
	05: Belgium		16: Australia
	06: Denmark		17: New Zealand
	07: Finland		18: Singapore
	08: Ireland		19: Malaysia
	09: Norway		1A: China
	0A: Sweden		1B: Taiwan
	0B: Switz.		1C: Korea
	0C: Portugal		20: Turkey
	0D: Holland		21: Greece
	0E: Spain		22: Hungary
	0F: Israel		23: Czech
10: ---	24: Poland		

System Switch 10 (SP No. 1-101-017)		
-------------------------------------	--	--

No	Function	Comments
0-7	Threshold memory level for parallel memory transmission	Threshold = N x 128 KB + 256 KB N can be between 00 - FF(H) Default setting: 02(H) = 512 KB

#### System Switch 11 (SP No. 1-101-018)

No	Function	Comments
0	TTI printing position 0: Superimposed on the page data 1: Printed before the data leading edge	Change this bit to 1 if the TTI overprints information that the customer considers to be important (G3 transmissions). <b>NOTE:</b> If "1" is selected, it is possible that sent data is printed on two sheets of paper.
1	TSI (G3) printing position 0: Superimposed on the page data 1: Printed before the data leading edge	Change this bit to 1 if the TSI (G3) overprints information that the customer considers to be important.
2	Not used	Do not change the factory settings.
3	TTI used for broadcasting 0: The TTIs selected for each Quick/Speed dial are used 1: The same TTI is used for all destinations	1: The TTI (TTI_1 or TTI_2) which is selected for all destinations during broadcasting.
4-7	Not used	Do not change the factory settings.

#### System Switch 12 (SP No. 1-101-019)

No	Function	Comments
0-7	TTI printing position in the main scan direction	TTI: 08 to 92 (BCD) mm Input even numbers only. This setting determines the print start position for the TTI from the left edge of the paper. If the TTI is moved too far to the right, it may overwrite the file number which is on the top right of the page. On an A4 page, if the TTI

		is moved over by more than 50 mm, it may overwrite the page number.
--	--	---

**System Switch 13** - Not used (do not change these settings)

**System Switch 14** - Not used (do not change these settings)

**System Switch 15 (SP No. 1-101-022)**

No	Function			Comments
0	Not used			Do not change the settings.
1	Going into the Energy Saver mode automatically 0: Enabled 1: Disabled			1: The machine will restart from the Energy Saver mode quickly, because the +5V power supply is active even in the Energy Saver mode. The LED of the operation switch is flashing instead of entering Energy Saver mode.  Use this setting if an external telephone has to be used when the machine is in the Energy Saver mode.
2-3	Not used			Do not change these settings.
4-5	Interval for preventing the machine from entering Energy Saver mode if there is a pending transmission file.			If there is a file waiting for transmission, the machine does not go to Energy Saver mode during the selected period.  After transmitting the file, if there is no file waiting for transmission, the machine goes to the Energy Saver mode.
	Bit 5	Bit 4	Setting	
	0	0	1 min	
	0	1	30 min	
	1	0	1 hour	
	1	1	24 hours	
6-7	Not used			Do not change

**System Switch 16 (SP No. 1-101-023)**

No	Function			Comments
0	Parallel Broadcasting 0: Disabled			1: The machine sends messages simultaneously using all available ports during broadcasting.

	1: Enabled	<b>NOTE:</b> If a customer wants to keep a line available for fax reception or other reasons, select "0" (Disable).
1	Priority setting for the G3 line. 0: PSTN-1 > PSTN-2 or 3 1: PSTN-2 or 3 > PSTN-1	This function allows the user to select the default G3 line type. The optional SG3 units are required to use the PSTN-2 or 3 setting.
2-7	Not used	Do not change these settings.

**System Switch 17** - Not used (do not change these settings)

**System Switch 18** - Not used (do not change these settings)

#### System Switch 19 (SP No. 1-101-026)

No	Function	Comments
0-5	Not used	Do not change the settings.
6	Extended scanner page memory after memory option is installed 0: Disabled 1: Enabled	0: After installing the memory expansion option, the scanner page memory is extended to 4 MB from 2 MB. 1: If this bit is set to 1 after installing the memory expansion option, the scanner page memory is extended to 12 MB. But the SAF memory decreases to 18 MB.
7	Special Original mode 0: Disabled 1: Enabled	1: If the customer frequently wishes to transmit a form or letterhead which has a colored or printed background, change this bit to "1". "Original 1" and "Original 2" can be selected in addition to the "Text", "Text/Photo" and "Photo" modes.

#### System Switch 1A (SP No. 1-101-027)

No	Function	Comments
0 to 7	LS RX memory capacity threshold setting 00-FF (0-1020 Kbyte: Hex)	Sets the value to x4KB. When the amount of available memory drops below this setting, RX documents are printed to conserve memory. Initial setting 0x80 (512 KB) <b>NOTE:</b> If a customer wants available memory size larger, decrease this threshold.

**System Switch 1B** - Not used (do not change these settings)

**System Switch 1C** - Not used (do not change these settings)

**System Switch 1D (SP No. 1-101-030)**

No	Function	Comments
0	RTI/CSI/CPS code display 0: Enable 1: Disable	0: RTI, CSI, CPS codes are displayed on the top line of the LCD panel during communication. 1: Codes are switched off (no display)
1-7	Not used	Do not change these settings.

4

**System Switch 1E (SP No. 1-101-031)**

No	Function	Comments
0	Communication after the Journal data storage area has become full 0: Impossible 1: Possible	0: When this switch is on and the journal history becomes full, the next report prints. If the journal history is not deleted, the next transmission cannot be received. This prevents overwriting communication records before the machine can print them. 1: If the buffer memory of the communication records for the Journal is full, fax communications are still possible. But the machine will overwrite the oldest communication records. <b>Note</b> <ul style="list-style-type: none"> <li>This setting is effective only when Automatic Journal printout is enabled but the machine cannot print the report (e.g., no paper).</li> </ul>
1	Action when the SAF memory has become full during scanning 0: The current page is erased. 1: The entire file is erased.	0: If the SAF memory becomes full during scanning at the memory transmission, the successfully scanned pages are transmitted. 1: If the SAF memory becomes full during scanning at the memory transmission, the file is erased and no pages are transmitted.



		<p><b>Note</b></p> <ul style="list-style-type: none"> <li>This setting is effective only when Automatic Journal printout is enabled but the machine cannot print the report (e.g., no paper).</li> </ul>
2	RTI/CSI display priority 0: RTI 1: CSI	This bit determines which identifier, RTI or CSI, is displayed on the LCD while the machine is communicating in G3 non-standard mode.
3	File No. printing 0: Enabled 1: Disabled	1: File numbers are not printed on any reports. <b>NOTE:</b> The file numbers may not be printed in the sequential order. If a customer does not like this numbering, select "0".
4	Action when authorized reception is enabled but authorized RTIs/CSIs are not yet programmed 0: All fax reception is disabled 1: Faxes can be received if the sender has an RTI or CSI	If authorized reception is enabled but the user has stored no acceptable sender RTIs or CSIs, the machine will not be able to receive any fax messages. If the customer wishes to receive messages from any sender that includes an RTI or CSI, and to block messages from senders that do not include an RTI or CSI, change this bit to "1", then enable Authorized Reception. Otherwise, keep this bit at "0 (default setting)".
5-7	Not used	Do not change the settings

#### System Switch 1F (SP No. 1-101-032)

No	Function	Comments
0	Not used	Do not change the settings.
1	Report printout after an original jam during SAF storage or if the SAF memory fills up 0: Enabled 1: Disabled	0: When an original jams, or the SAF memory overflows during scanning, a report will be printed. Change this bit to "1" if the customer does not want to have a report in these cases. Memory tx – Memory storage report Parallel memory tx – Transmission result report
2	Not used	Do not change the settings.
3	Received fax print start timing (G3 reception)	0: The machine prints each page immediately after the machine receives it.

	0: After receiving each page 1: After receiving all pages	1: The machine prints the complete message after the machine receives all the pages in the memory.
4-6	Not used	Do not change the factory settings.
7	Action when a fax SC has occurred 0: Automatic reset 1: Fax unit stops	0: When the fax unit detects a fax SC code other than SC1201 and SC1207, the fax unit automatically resets itself. 1: When the fax unit detects any fax SC code, the fax unit stops. <b>Cross Reference</b> Fax SC codes - See "Troubleshooting"

### I-Fax Switches

I-fax Switch 00 (SP No. 1-102-001)		
No	Function	Comments
Original Width of TX Attachment File		This setting sets the maximum size of the original that the destination can receive. (Bits 3~7 are reserved for future use or not used.)
0	A4	-
1	B4	
2	A3	
3-6	Reserved	
7	Not used	
<p>0: Off (not selected), 1: On (selected)</p> <p>If more than one of these three bits is set to "1", the larger size has priority. For example, if both Bit 2 and Bit 1 are set to "1" then the maximum size is "A3" (Bit 2).</p> <p>When mail is sent, there is no negotiation with the receiving machine at the destination, so the sending machine cannot make a selection for the receiving capabilities (original width setting) of the receiving machine. The original width selected with this switch is used as the RX machine's original width setting, and the original is reduced to this size before sending. The default is A4.</p> <p>If the width selected with this switch is higher than the receiving machine can accept, the machine detects this and this causes an error.</p>		

I-fax Switch 01 (SP No. 1-102-002)		
No	Function	Comments
Original Line Resolution of TX Attachment File		These settings set the maximum resolution of the original that the destination can receive.
0	200x100 Standard	0: Not selected 1: Selected If more than one of these three bits is set to "1", the higher resolution has priority. For example, if both Bit 0 and Bit 2 are set to "1" Then The Resolution is set for "Bit 2 200 x 400."
1	200x200 Detail	
2	200x400 Fine	
3	300 x 300 Reserve	
4	400 x 400 Super Fine	
5	600 x 600 Reserve	
6	Reserve	
7	mm/inch	
<p>This setting selects mm/inch conversion for mail transmission.            0: Off (No conversion), 1: On (Conversion)</p> <p>When on (set to "1"), the machine converts millimeters to inches for sending mail. There is no switch for converting inches to millimeters.</p> <p>Unlike G3 fax transmissions which can negotiate between sender and receiver to determine the setting, mail cannot negotiate between terminals; the mm/inch selection is determined by the sender fax.</p> <p>When this switch is Off (0):</p> <ul style="list-style-type: none"> <li>• Images scanned in inches are sent in inches.</li> <li>• Images scanned in mm are sent in mm.</li> <li>• Images received in inches are transmitted in inches.</li> <li>• Images received in mm are transmitted in mm.</li> </ul> <p>When this switch is On (1):</p> <ul style="list-style-type: none"> <li>• Images scanned in inches are sent in inches.</li> <li>• Images scanned in mm are converted to inches.</li> <li>• Images received in inches are transmitted in inches.</li> <li>• Images received in mm are converted to inches.</li> </ul>		

## I-fax Switch 02 (SP No. 1-102-003)

No	Function	Comments
0	RX Text Mail Header Processing	
		<p>This setting determines whether the header information is printed with text e-mails when they are received.</p> <p>0: Prints only text mail.</p> <p>1: Prints mail header information attached to text mail.</p> <p>When a text mail is received with this switch On (1), the "From" address and "Subject" address are printed as header information.</p> <p>When a mail with only binary data is received (a TIFF-F file, for example), this setting is ignored and no header is printed.</p>
1	Output from Attached Document at E-mail TX Error	
		<p>This setting determines whether only the first page or all pages of an e-mail attachment are printed at the sending station when a transmission error occurs. This allows the customer to see which documents have not reached their intended destinations if sent to the wrong e-mail addresses, for example.</p> <p>0: Prints 1st page only.</p> <p>1: Prints all pages.</p>
2-3	Text String for Return Receipt	
		<p>This setting determines the text string output for the Return Receipt that confirms the transmission was received normally at the destination.</p>
	<p>00: "Dispatched"</p> <p>Sends from PC mail a request for a Return Receipt. Receives the Return Receipt with "dispatched" in the 2nd part:</p> <p>Disposition: Automatic-action/MDN-send automatically; dispatched</p> <p>The "dispatched" string is included in the Subject string.</p> <p>01: "Displayed"</p> <p>Sends from PC mail a request for a Return Receipt. Receives the Return Receipt with "displayed" in the 2nd part:</p> <p>Disposition: Automatic-action/MDN-send automatically; displayed</p> <p>The "displayed" string is included in the Subject string.</p> <p>10: Reserved</p> <p>11: Reserved</p>	

	A mail requesting a Return Receipt sent from an IFAX with this switch set to "00" (for "dispatched") received by Microsoft Outlook 2000 may cause an error. If any setting other than "displayed" (01) causes a problem, change the setting to "01" to enable normal sending of the Return Receipt.
4	Media accept feature
	<p>This setting adds or does not add the media accept feature to the answer mail to confirm a reception.</p> <p>0: Does not add the media accept feature to the answer mail</p> <p>1: Adds the media accept feature to the answer mail.</p> <p>Use this bit switch if a problem occurs when the machine receives an answer mail, which contains the media accept feature field.</p>
5-6	Not Used
7	Image Resolution of RX Text Mail
	<p>This setting determines the image resolution of the received mail.</p> <p>0: 200 x 200</p> <p>1: 400 x 400</p> <p>The "1" setting requires installation of the Function Upgrade Card in order to have enough SAF (Store and Forward) memory to receive images at 400 x 400 resolution.</p>

I-fax Switch 03 (SP No. 1-102-004)		
No	Function	Comments
0	Original Output at Transfer Station	
	<p>This setting determines whether the original is output at the transfer station when it is received from the sender that initiated the transfer transmission. This feature is the same as for G3 transfer transmissions.</p> <p>0: Received original not output at the transfer station.</p> <p>1: Received original output. The original is printed after the transfer station has transferred it to the destinations, so its output confirms that the original has been transferred.</p>	
1	Transfer Result Report	
	<p>This setting determines when a Transfer Result Report is generated and returned to the transfer requestor.</p> <p>0: Returns the report after each transfer.</p>	

	1: Returns the report only if an error occurred during transfer.
2	Destination Error Handling for Reception Transfer Request
	<p>This setting restricts transfer transmission based on whether the final destinations are correct or not.</p> <p>0: The transfer station transmits to correct destinations only (addresses with no errors in them).</p> <p>1: If any address has an error in it, the transfer station transfers no transmissions and returns a transfer transmission failure report to the requestor that initiated the transfer.</p> <p>There is no negotiation between the transfer initiator and the transfer station to determine whether the final destination addresses are correct or not. This setting determines whether or not the transfer station transfers the transmissions if there is a mistake in even one of the final destination addresses.</p>
3	Polling ID Check for Reception of Transfer Request
	<p>This setting determines whether the polling IDs of incoming transmissions are checked to ensure that the polling IDs match.</p> <p>0: Receives and transfers only messages that have matching polling IDs.</p> <p>1: Receives and transfers all messages, even if the polling IDs do not match.</p>
4-7	Not Used

I-fax Switch 04 (SP No. 1-102-005)		
No	Function	Comments
0	Subject for Delivery TX/Memory Transfer	
		<p>This setting determines whether the RTI/CSI registered on this machine or the RTI/CSI of the originator is used in the subject lines of transferred documents.</p> <p>0: Puts the RTI/CSI of the originator in the Subject line. If this is used, either the RTI or CSI is used. Only one of these can be received for use in the subject line.</p> <p>1: Puts the RTI/CSI registered on this machine in the Subject line.</p> <p>When this switch is used to transfer and deliver mail to a PC, the information in the Subject line that indicates where the transmission originated can be used to determine automatically the destination folder for each e-mail.</p>
1	Subject corresponding to mail post database	
	0: Standard subject	
	1: Mail post database subject	
	The standard subject is replaced by the mail post database subject in the following three cases:	

	<p>1) When the service technician sets the service (software) switch.</p> <p>2) When memory sending or delivery specified by F code is applied by the SMTP server</p> <p>3) With relay broadcasting (1st stage without the Schmidt 4 function).</p> <p><b>Note</b></p> <ul style="list-style-type: none"> <li>This switch does not apply for condition 3) when the RX system is set up for memory sending, delivery by F-code, sending with SMTP RX and when operators are using FOL (to prevent problems when receiving transmissions).</li> </ul>
2-7	Not Used

#### I-fax Switch 05 (SP No. 1-102-006)

No	Function	Comments
0	Mail Addresses of SMTP Broadcast Recipients	<p>Determines whether the e-mail addresses of the destinations that receive transmissions broadcasted using SMTP protocol are recorded in the Journal.</p> <p>For example:</p> <p>"1st destination + Total number of destinations: 9" in the Journal indicates a broadcast to 9 destinations.</p> <p>0: Not recorded 1: Recorded</p>
1-7	Not Used	

**I-fax Switch 06** - Not used (do not change the settings)

**I-fax Switch 07** - Not used (do not change the settings)

#### I-fax Switch 08 (SP No. 1-102-009)

No	Function	Comments
0-7	Memory Threshold for POP Mail Reception	<p>This setting determines the amount of SAF (Store and Forward) memory. (SAF stores fax messages to send later for transmission to more than one location, and also holds incoming messages if they cannot be printed.) When the amount of SAF memory available falls below this setting, mail can no longer be received; received mail is then stored on the mail server.</p> <p>00-FF (0 to 1024 KB: HEX)</p>

	The hexadecimal number you enter is multiplied by 4 KB to determine the amount of memory.
--	---

I-fax Switch 09 (SP No. 1-102-010)		
No	Function	Comments
0-3	Not used	Do not change the settings
4-7	Restrict TX Retries	This setting determines the number of retries when connection and transmission fails due to errors. 01-F (1-15 Hex)

4

I-fax Switch 0A - Not used (do not change the settings)
I-fax Switch 0B - Not used (do not change the settings)
I-fax Switch 0C - Not used (do not change the settings)
I-fax Switch 0D - Not used (do not change the settings)
I-fax Switch 0E - Not used (do not change the settings)

I-fax Switch 0F (SP No. 1-102-016)		
No	Function	Comments
0	Delivery Method for SMTP RX Files	This setting determines whether files received with SMTP protocol are delivered or output immediately. 0: Off. Files received via SMTP are output immediately without delivery. 1: On. Files received via SMTP are delivered immediately to their destinations.
	Not used	
1-7	Not used	

**Printer Switches**

Printer Switch 00 (SP No. 1-103-001)		
No	Function	Comments



0	Select page separation marks 0: Off 1: On	<p>0: If a 2 page RX transmission is split, [*] is printed in the bottom right corner of the 1st page and only a [2] is printed in the upper right corner of the 2nd page.</p> <p>1: If a 2 page RX transmission is split into two pages, for example, [*] [2] is printed in the bottom right corner of the 1st page and only a [2] is printed in the upper right corner of the 2nd page.</p> <p><b>Note</b></p> <ul style="list-style-type: none"> <li>This helps the user to identify pages that have been split because the size of the paper is smaller than the size of the document received. (When A5 is used to print an A4 size document, for example.)</li> </ul>
1	Repetition of data when the received page is longer than the printer paper 0: Off 1: On	<p>1: Default. 10 mm of the trailing edge of the previous page are repeated at the top of the next page.</p> <p>0: The next page continues from where the previous page stopped without any repeated text.</p>
2	Prints the date and time on received fax messages 0: Disabled 1: Enabled	<p>This switch is only effective when user parameter 02 - bit 2 (printing the received date and time on received fax messages) is enabled.</p> <p>1: The machine prints the received and printed date and time at the bottom of each received page.</p>
3-7	Not used	Do not change the settings.

Printer Switch 01 (SP No. 1-103-002)				
No	Function			Comments
0-2	Not used			Do not change the settings.
3-4	Maximum print width used in the setup protocol			These bits are only effective when bit 7 of printer switch 01 is "1".
	Bit 4	Bit 3	Setting	
	0	0	Not used	
	0	1	A3	
	1	0	B4	

	1	1	A4	
5-6	Not used			Do not change the settings.
7	Received message width restriction in the protocol signal to the sender 0: Disabled 1: Enabled			0: The machine informs the transmitting machine of the print width depending on the paper size available from the paper feed stations. Refer to the table on the next page for how the machine chooses the paper width used in the setup protocol (NSF/DIS). 1: The machine informs the transmitting machine of the fixed paper width which is specified by bits 3 and 4 above.

**Relationship between available paper sizes and printer width used in the setup protocol**

Available Paper Size	Printer width used in the Protocol (NSF/DIS)
A4 or 8.5" x 11"	297 mm width
B5	256 mm width
A5 or 8.5" x 5.5"	216 mm width
No paper available (Paper end)	216 mm width

Printer Switch 02 (SP No. 1-103-003)		
No	Function	Comments
0	1st paper feed station usage for fax printing 0: Enabled 1: Disabled	0: The paper feed station can be used to print fax messages and reports. 1: The specified paper feed station will not be used for printing fax messages and reports. <b>Note</b> • Do not disable usage for a paper feed station which has been specified by User Parameter Switch OF (15), or which is used for the Specified Cassette Selection feature.
1	2nd paper feed station usage for fax printing 0: Enabled 1: Disabled	
2	3rd paper feed station usage for fax printing 0: Enabled	

	1: Disabled	
3	4th paper feed station usage for fax printing 0: Enabled 1: Disabled	
4	LCT usage for fax printing 0: Enabled 1: Disabled	
5-7	Not used	Do not change the settings.

Printer Switch 03 (SP No. 1-103-004)		
No	Function	Comments
0	Length reduction of received data 0: Disabled 1: Enabled	0: Incoming pages are printed without length reduction. (Page separation threshold: Printer Switch 03, bits 4 to 7) 1: Incoming page length is reduced when printing. (Maximum reducible length: Printer Switches 04, bits 0 to 4)
1-3	Not used	Do not change the settings
4 to 7	Page separation setting when sub scan compression is forbidden 00-0F (0-15 mm: Hex) Default: 6 mm	Page separation threshold (with reduction disabled with switch 03-0 above). For example, if this setting is set to "10", and A4 is the selected paper size: If the received document is 10 mm or less longer than A4, then the 10 mm are cut and only 1 page prints. If the received document is 10 mm longer than A4, then the document is split into 2 pages.

Printer Switch 04 (SP No. 1-103-005)		
No	Function	Comments
0 to	Maximum reducible length when length reduction is enabled with switch 03-0 above. [Maximum reducible length] = [Paper length] + (N x 5mm)	

4	"N" is the decimal value of the binary setting of bits 0 to 4.					
	Bit 4	Bit 3	Bit 2	Bit 1	Bit 0	Setting
	0	0	0	0	0	0 mm
	0	0	0	0	1	5 mm
	0	0	1	0	0	20 mm
	1	1	1	1	1	155 mm
For A5 sideways and B5 sideways paper [Maximum reducible length] = [Paper length] + 0.75 x (N x 5mm)						
5 6	Length of the duplicated image on the next page, when page separation has taken place.					
	Bit 6		Bit 5		Setting	
	0		0		4 mm	
	0		1		10 mm	
	1		0		15 mm	
1		1		Not used		
7	Not used.			Do not change the setting.		

**Printer Switch 05** - Not used (do not change the settings)

**Printer Switch 06 (SP No. 1-103-007)**

No	Function	Comments
0	Printing while a paper cassette is pulled out, when the Just Size Printing feature is enabled. 0: Printing will not start 1: Printing will start if another cassette has a suitable size of paper, based on the paper size selection priority tables.	Cross reference Just size printing on/off – User switch 05, bit 5
1-7	Not used.	Do not change the settings.

Printer Switch 07 (SP No. 1-103-008)		
No	Function	Comments
0	Reduction for Journal printing 0: Off 1: On	1: The Journal is reduced to 91% to ensure that there is enough space in the left margin for punch holes or staples.
2-3	Not used.	Do not change the settings.
4	List of destinations in the Communication Failure Report for broadcasting 0: All destinations 1: Only destinations where communication failure occurred	1: Only destinations where communication failure occurred are printed on the Communication Failure Report.
5-7	Not used.	Do not change the settings.

**Printer Switch 08** - Not used (do not change the settings)

**Printer Switch 09** - Not used (do not change the settings)

**Printer Switch 0A** - Not used (do not change the settings)

**Printer Switch 0B** - Not used (do not change the settings)

**Printer Switch 0C** - Not used (do not change the settings)

**Printer Switch 0D** - Not used (do not change the settings)

Printer Switch OE (SP No. 1-103-015)		
No	Function	Comments
0	Paper size selection priority 0: Width 1: Length	0: A paper size that has the same width as the received data is selected first. 1: A paper size which has enough length to print all the received lines without reduction is selected first.
1	Paper size selected for printing A4 width fax data 0: 8.5" x 11" size	This switch determines which paper size is selected for printing A4 width fax data, when the machine has both A4 and 8.5" x 11" size paper.

	1: A4 size			
2	Page separation 0: Enabled 1: Disabled			1: If all paper sizes in the machine require page separation to print a received fax message, the machine does not print the message (Substitute Reception is used).  After a larger size of paper is set in a cassette, the machine automatically prints the fax message.
3-4	Printing the sample image on reports			"Same size" means the sample image is printed at 100%, even if page separation occurs.  User Parameter Switch 19 (13H) bit 4 must be set to "0" to enable this switch.  Refer to Detailed Section Descriptions for more on this feature.
	Bit 4	Bit 3	Setting	
	0	0	The upper half only	
	0	1	50% reduction (sub-scan only)	
	1	0	Same size	
	1	1	Not used	
5-6	Not used			Do not change the settings.
7	Equalizing the reduction ratio among separated pages (Page Separation) 0: Enabled 1: Disabled			0: When page separation has taken place, all the pages are reduced with the same reduction ratio.  1: Only the last page is reduced to fit the selected paper size when page separation has taken place. Other pages are printed without reduction.

Printer Switch OF (SP No. 1-103-016)				
No	Function			Comments
0-1	Smoothing feature			(0, 0) (0, 1): Disable smoothing if the machine receives halftone images from other manufacturers fax machines frequently.
	Bit 1	Bit 0	Setting	
	0	0	Disabled	
	0	1	Disabled	
	1	0	Enabled	

	1	1	Not used	
2	Duplex printing 0: Disabled 1: Enabled			1: The machine always prints received fax messages in duplex printing mode:
3	Binding direction for Duplex printing 0: Left binding 1: Top binding			0: Sets the binding for the left edge of the stack. 1: Sets the binding for the top of the stack.
4-7	Not used			Do not change the settings.

## Communication Switches

Communication Switch 00 (SP No. 1-104-001)				
No	Function			Comments
0-1	Compression modes available in receive mode			
	Bit 1	Bit 0	Modes	
	0	0	MH only	
	0	1	MH/MR	
	1	0	MH/MR/MMR	
	1	1	MH/MR/MMR/JBIG	
2-3	Compression modes available in transmit mode			
	Bit 3	Bit 2	Modes	
	0	0	MH only	
	0	1	MH/MR	
	1	0	MH/MR/MMR	
	1	1	MH/MR/MMR/JBIG	
4	Not used			Do not change the settings.
5	JBIG compression method: Reception 0: Only basic supported			Change the setting when communication problems occur using JBIG compression.

	1: Basic and optional both supported	
6	JBIG compression method: Transmission 0: Basic mode priority 1: Optional mode priority	Change the setting when communication problems occur using JBIG compression.
7	Closed network (reception) 0: Disabled 1: Enabled	1: Reception will not go ahead if the polling ID code of the remote terminal does not match the polling ID code of the local terminal. This function is only available in NSF/NSS mode.

4

Communication Switch 01 (SP No. 1-104-002)				
No	Function			Comments
0	ECM 0: Off 1: On			If this bit is set to 0, ECM is switched off for all communications.  In addition, V.8 protocol and JBIG compression are switched off automatically.
1	Not used			Do not change the setting.
2-3	Wrong connection prevention method			(0, 1): The machine will disconnect the line without sending a fax message, if the last 8 digits of the received CSI do not match the last 8 digits of the dialed telephone number. This does not work when manually dialed.  (1, 0): The same as above, except that only the last 4 digits are compared.  (1, 1): The machine will disconnect the line without sending a fax message, if the other end does not identify itself with an RTI or CSI.  (0, 0): Nothing is checked; transmission will always go ahead.  <div style="border: 1px solid black; border-radius: 10px; padding: 2px; display: inline-block;"> <span style="font-size: 0.8em;">⬇</span> <b>Note</b> </div> <ul style="list-style-type: none"> <li>• This function does not work when dialing is done from the external telephone.</li> </ul>
	Bit 3	Bit 2	Setting	
	0	0	None	
	0	1	8 digit CSI	
	1	0	4 digit CSI	
	1	1	CSI/RTI	
4-5	Not used			Do not change the setting.



6-7	Maximum printable page length available			The setting determined by these bits is informed to the transmitting terminal in the pre-message protocol exchange (in the DIS/NSF frames).
	Bit 7	Bit 6	Setting	
	0	0	No limit	
	0	1	B4 (364 mm)	
	1	0	A4 (297 mm)	
	1	1	Not used	

#### Communication Switch 02 (SP No. 1-104-003)

No	Function	Comments
0	G3 Burst error threshold 0: Low 1: High	If there are more consecutive error lines in the received page than the threshold, the machine will send a negative response. The Low and High threshold values depend on the sub-scan resolution, and are as follows.
		100 dpi      6(L) → 12(H)
		200 dpi      12(L) → 24(H)
		300 dpi      18(L) → 36(H)
		400 dpi      24(L) → 48(H)
1	Acceptable total error line ratio 0: 5% 1: 10%	If the error line ratio for a page exceeds the acceptable ratio, RTN will be sent to the other end.
2	Treatment of pages received with errors during G3 reception 0: Deleted from memory without printing 1: Printed	0: Pages received with errors are not printed.
3	Hang-up decision when a negative code (RTN or PIN) is received during G3 immediate transmission 0: No hang-up, 1: Hang-up	0: The next page will be sent even if RTN or PIN is received. 1: The machine will send DCN and hang up if it receives RTN or PIN. This bit is ignored for memory transmissions or if ECM is being used.

4-7	Not used	Do not change the settings.
-----	----------	-----------------------------

Communication Switch 03 (SP No. 1-104-004)		
No	Function	Comments
0-7	Maximum number of page retransmissions in a G3 memory transmission	00 - FF (Hex) times. This setting is not used if ECM is switched on. Default setting - 03(H)

4

<b>Communication Switch 04</b> - Not used (do not change the settings)
<b>Communication Switch 05</b> - Not used (do not change the settings)
<b>Communication Switch 06</b> - Not used (do not change the settings)
<b>Communication Switch 07</b> - Not used (do not change the settings)
<b>Communication Switch 08</b> - Not used (do not change the settings)
<b>Communication Switch 09</b> - Not used (do not change the settings)

Communication Switch 0A (SP No. 1-104-011)		
No	Function	Comments
0	Point of resumption of memory transmission upon redialing 0: From the error page 1: From page 1	0: The transmission begins from the page where transmission failed the previous time. 1: Transmission begins from the first page, using normal memory transmission.
1-7	Not used	Do not change the settings.

Communication Switch 0B (SP No. 1-104-012)		
No	Function	Comments
0	Use of Economy Transmission during a Transfer operation to end receivers 0: Disabled, 1: Enabled	These bits determine whether the machine uses the Economy Transmission feature when it is carrying out a Transfer operation as a Transfer Station.

1	Use of Economy Transmission during a Transfer operation to the Next Transfer Stations 0: Disabled, 1: Enabled	
2	Use of Label Insertion for the End Receivers in a Transfer operation 0: Disabled, 1: Enabled	This bit determines whether the machine uses the Label Insertion feature when it is carrying out a Transfer operation as a Transfer Station.
3	Conditions required for Transfer Result Report transmission 0: Always transmitted 1: Only transmitted if there was an error	0: When acting as a Transfer Station, the machine will always send a Transfer Result Report back to the Requesting Station after completing the Transfer Request, even if there were no problems. 1: The machine will only send back a Transfer Result Report if there were errors during communication, meaning one or more of the End Receivers could not be contacted.
4	Printout of the message when acting as a Transfer Station 0: Disabled, 1: Enabled	When the machine is acting as a Transfer Station, this bit determines whether the machine prints the fax message coming in from the Requesting Terminal.
5	Action when there is no fax number in the programmed Quick/Speed dials which meets the requesting terminal's own fax number 0: Transfer is disabled 1: Transfer is enabled	After the machine receives a transfer request, the machine compares the last N digits of the requesting terminal's own fax number with all the Quick/Speed dials programmed in the machine. (N is the number programmed in communication switch 0C.) 0: If there is no matching number programmed in the machine, the machine rejects the transfer request. 1: Even if there is no matching number programmed in the machine, the machine accepts the transfer request. The result report will be printed at the transfer terminal, but will not be sent back to the requesting terminal.
6-7	Not used	Do not change the settings.

#### Communication Switch 0C (SP No. 1-104-013)

No	Function	Comments
0-4	Number of digits compared to find the requester's fax number from the	00 – 1F (0 to 31 digits)

	programmed Quick/Speed Dials when acting as a Transfer Station	<p>After the machine receives a transfer request, the machine compares the own telephone number sent from the Requesting Terminal with all Quick/Speed Dials programmed in the machine, starting from Quick Dial 01 to the end of the Speed Dials.</p> <p>This number determines how many digits from the end of the telephone numbers the machine compares.</p> <p>If it is set to 00, the machine will send the report to the first Quick/Speed Dial that the machine compared. If Quick Dial 01 is programmed, the machine will send the report to Quick 01. If Quick Dial 01 through 04 are not programmed and Quick Dial 05 is programmed, the machine will send the report to Quick 05.</p> <p>Default setting – 05(H) = 5 digits</p>
5-7	Not used	Do not change the settings.

Communication Switch OD (SP No. 1-104-014)		
No	Function	Comments
0-7	The available memory threshold, below which ringing detection (and therefore reception into memory) is disabled	<p>00 to FF (Hex), unit = 4 kbytes (e.g., 06(H) = 24 kbytes)</p> <p>One page is about 24 kbytes.</p> <p>The machine refers to this setting before each fax reception. If the amount of remaining memory is below this threshold, the machine cannot receive any fax messages.</p> <p>If this setting is kept at 0, the machine will detect ringing signals and go into receive mode even if there is no memory available. This will result in communication failure.</p>

Communication Switch OE (SP No. 1-104-015)		
No	Function	Comments
0-7	Minimum interval between automatic dialing attempts	<p>06 to FF (Hex), unit = 2 s (e.g., 06(H) = 12 s)</p> <p>This value is the minimum time that the machine waits before it dials the next destination.</p>

**Communication Switch 0F** – Not used (do not change the settings.)

**Communication Switch 10 (SP No. 1-104-017)**

No	Function	Comments
0-7	Memory transmission: Maximum number of dialing attempts to the same destination	01 – FE (Hex) times

**Communication Switch 11** – Not used (do not change the settings.)

**Communication Switch 12 (SP No. 1-104-019)**

No	Function	Comments
0-7	Memory transmission: Interval between dialing attempts to the same destination	01 – FF (Hex) minutes

**Communication Switch 13** – Not used (do not change the settings.)

**Communication Switch 14 (SP No. 1-104-021)**

No	Function	Comments
0	Inch-to-mm conversion during transmission 0: Disabled, 1: Enabled	0: In immediate transmission, data scanned in inch format are transmitted without conversion. In memory transmission, data stored in the SAF memory in mm format are transmitted without conversion. Note: When storing the scanned data into SAF memory, the fax unit always converts the data into mm format. 1: The machine converts the scanned data or stored data in the SAF memory to the format which was specified in the set-up protocol (DIS/NSF) before transmission.
1-5	Not used	Do not change the factory settings.

6-7	Available unit of resolution in which fax messages are received			<p>For the best performance, do not change the factory settings.</p> <p>The setting determined by these bits is informed to the transmitting terminal in the pre-message protocol exchange (in the DIS/NSF frames).</p>
	Bit 7	Bit 6	Unit	
	0	0	mm	
	0	1	inch	
	1	0	mm and inch	
1	1	Not used		

4

**Communication Switch 15** – Not used (do not change the settings)

Communication Switch 16 (SP No. 1-104-023)		
No	Function	Comments
0	Not used	Do not change the settings.
1	Optional G3 unit (G3-2) 0: Not installed 1: Installed	Change this bit to 1 when installing the first optional G3 unit.
2	Not used	
3	Select PSTN connection 0: Off 1: On	<p>This switch enables the G3-2.</p> <p>0: Off, no connection</p> <p>1: Recognizes and enables G3-2.</p> <p>This switch can be used only after G3-2 has been installed.</p>
4-7	Not used	Do not change the settings.

Communication Switch 17 (SP No. 1-104-024)		
No	Function	Comments
0	SEP reception 0: Disabled 1: Enabled	0: Polling transmission to another maker's machine using the SEP (Selective Polling) signal is disabled.

1	SUB reception 0: Disabled 1: Enabled	0: Confidential reception to another maker's machine using the SUB (Sub-address) signal is disabled.
2	PWD reception 0: Disabled 1: Enabled	0: Disables features that require PWD (Password) signal reception.
3-6	Not used	Do not change the settings.
7	Action when there is no box with an F-code that matches the received SUB code 0: Disconnect the line 1: Receive the message (using normal reception mode)	Change this setting when the customer requires.

**Communication Switch 18** - Not used (do not change the settings)

**Communication Switch 19** - Not used (do not change the settings)

**Communication Switch 1A** - Not used (do not change the settings)

#### Communication Switch 1B (SP No. 1-104-028)

No	Function	Comments
0-7	Extension access code (0 to 7) to turn V.8 protocol On/Off 0: On 1: Off	If the PABX does not support V.8/V.34 protocol procedure, set this bit to "1" to disable V.8.  Example: If "0" is the PSTN access code, set bit 0 to 1. When the machine detects "0" as the first dialed number, it automatically disables V.8 protocol. (Alternatively, if "3" is the PSTN access code, set bit 3 to 1.)

#### Communication Switch 1C (SP No. 1-104-029)

No	Function	Comments
0-1	Extension access code (8 and 9) to turn V.8 protocol On/Off 0: On	Refer to communication switch 1B.  Example: If "8" is the PSTN access code, set bit 0 to 1. When the machine detects "8" as the first dialed number,

	1: Off	it automatically disables V.8 protocol. (If "9" is the PSTN access code, use bit 1.)
2-7	Not used	Do not change the settings.

<b>Communication Switch 1D</b> - Not used (do not change the settings)
<b>Communication Switch 1E</b> - Not used (do not change the settings)
<b>Communication Switch 1F</b> - Not used (do not change the settings)

4

**G3 Switches**

G3 Switch 00 (SP No. 1-105-001)				
No	Function			Comments
0 1	Monitor speaker during communication (tx and rx)			(0, 0): The monitor speaker is disabled all through the communication. (0, 1): The monitor speaker is on up to phase B in the T.30 protocol. (1, 0): Used for testing. The monitor speaker is on all through the communication. Make sure that you reset these bits after testing.
	Bit 1	Bit 0	Setting	
	0	0	Disabled	
	0	1	Up to Phase B	
	1	0	All the time	
	1	1	Not used	
2	Monitor speaker during memory transmission 0: Disabled 1: Enabled			1: The monitor speaker is enabled during memory transmission.
3-7	Not used			Do not change the settings.

G3 Switch 01 (SP No. 1-105-002)		
No	Function	Comments
0	Not used	Do not change the settings.
1	Select V.8 protocol for manual RX function	This switch switches the V.8 protocol for manual receiving off and on.



	0: No 1: Yes	
2-3	Not used	Do not change the settings.
4	DIS frame length 0: 10 bytes 1: 4 bytes	1: The bytes in the DIS frame after the 4th byte will not be transmitted (set to 1 if there are communication problems with PC-based faxes which cannot receive the extended DIS frames).
5	Not used	Do not change the setting.
6	Forbid CED/AMsam output 0: Off 1: On (Forbid output)	Do not change this setting (Default: 0: Off), unless communication problem is caused by a CED or ANSam transmission.
7	Not used	Do not change the setting.

G3 Switch 02 (SP No. 1-105-003)		
No	Function	Comments
0	G3 protocol mode used 0: Standard and non-standard 1: Standard only	Change this bit to 1 only when the other end can only communicate with machines that send T.30-standard frames only.  1: Disables NSF/NSS signals (these are used in non-standard mode communication)
1-4	Not used	Do not change the settings.
5	Use of modem rate history for transmission using Quick/Speed Dials 0: Disabled 1: Enabled	0: Communications using Quick/Speed Dials always start from the highest modem rate.  1: The machine refers to the modem rate history for communications with the same machine when determining the most suitable rate for the current communication.
6	Not Used	Do not change the settings.
7	Short preamble 0: Disabled 1: Enabled	Refer to Appendix B in the Group 3 Facsimile Manual for details about Short Preamble.

<b>G3 Switch 03 (SP No. 1-105-004)</b>
--

No	Function	Comments
0	DIS detection number (Echo countermeasure) 0: 1 1: 2	0: The machine will hang up if it receives the same DIS frame twice. 1: Before sending DCS, the machine will wait for the second DIS which is caused by echo on the line.
1	Not Used	Do not change the settings.
2	V.8 protocol 0: Disabled 1: Enabled	0: V.8/V.34 communications will not be possible. <b>Note</b> <ul style="list-style-type: none"> <li>Do not set to 0 unless the line condition is always bad enough to slow down the data rate to 14.4 kbps or lower.</li> </ul>
3	ECM frame size 0: 256 bytes 1: 64 bytes	Keep this bit at "0" in most cases.
4	CTC transmission conditions 0: After one PPR signal received 1: After four PPR signals received (ITU-T standard)	0: When using ECM in non-standard (NSF/NSS) mode, the machine sends a CTC to drop back the modem rate after receiving a PPR, if the following condition is met in communications at 14.4, 12.0, 9.6, and 7.2 kbps. $\sqrt{N_{\text{Transmit}}} \leq N_{\text{Resend}}$ <p><math>N_{\text{Transmit}}</math>- Number of transmitted frames  <math>N_{\text{Resend}}</math>- Number of frames to be retransmitted</p> 1: When using ECM, the machine sends a CTC to drop back the modem rate after receiving four PPRs. PPR, CTC: These are ECM protocol signals. This bit is not effective in V.34 communications.
5	Modem rate used for the next page after receiving a negative code (RTN or PIN) 0: No change 1: Fallback	1: The machine's tx modem rate will fall back before sending the next page if a negative code is received. This bit is ignored if ECM is being used.
6	Not used	Do not change the settings

7	Select detection of reverse polarity in ringing 0: Off 1: On	This switch is used to prevent reverse polarity in ringing on the phone line (applied to PSTN-G3 ringing). Do not change this setting  0: No detection (Outside Japan) 1: Detection (Inside Japan only)
---	--	--

#### G3 Switch 04 (SP No. 1-105-005)

No	Function	Comments
0-3	Training error detection threshold	0 - F (Hex); 0 - 15 bits If the number of error bits in the received TCF is below this threshold, the machine informs the sender that training has succeeded.
4-7	Not used	Do not change the settings.

#### G3 Switch 05 (SP No. 1-105-006)

No	Function					Comments
0-3	Initial Tx modem rate (kbps)					These bits set the initial starting modem rate for transmission.  Use the dedicated transmission parameters if you need to change this for specific receivers.  If a modem rate 14.4 kbps or slower is selected, V.8 protocol should be disabled manually.  Cross reference V.8 protocol on/off - G3 switch 03, bit 2
	Bit 3	Bit 2	Bit 1	Bit 0	kbps	
	0	0	0	1	2.4	
	0	0	1	0	4.8	
	0	0	1	1	7.2	
	0	1	0	0	9.6	
	0	1	0	1	12.0	
	0	1	1	0	14.4	
	0	1	1	1	16.8	
	1	0	0	0	19.2	
	1	0	0	1	21.6	
1	0	1	0	24.0		

	1	0	1	1	26.4	
	1	1	0	0	28.8	
	1	1	0	1	31.2	
	0	0	1	1	33.6	
	Other settings - Not used					
4-5	Initial modem type for 9.6 k or 7.2 kbps.					These bits set the initial modem type for 9.6 and 7.2 kbps, if the initial modem rate is set at these speeds.
	Bit 5	Bit 4	Setting			
	0	0	V.29			
	0	1	V.17			
	1	0	V.34			
1	1	Not used				
6-7	Not used				Do not change the settings.	

G3 Switch 06 (SP No. 1-105-007)						
No	Function					Comments
0-3	Initial Rx modem rate(kbps)					These bits set the initial starting modem rate for reception. Use a lower setting if high speeds pose problems during reception. If a modem rate 14.4 kbps or slower is selected, V.8 protocol should be disabled manually. Cross reference V.8 protocol on/off - G3 switch 03, bit2
	Bit 3	Bit 2	Bit 1	Bit 0	kbps	
	0	0	0	1	2.4	
	0	0	1	0	4.8	
	0	0	1	1	7.2	
	0	1	0	0	9.6	
	0	1	0	1	12.0	
	0	1	1	0	14.4	
	0	1	1	1	16.8	
	1	0	0	0	19.2	
1	0	0	1	21.6		

	1	0	1	0	24.0	
	1	0	1	1	26.4	
	1	1	0	0	28.8	
	1	1	0	1	31.2	
	Other settings - Not used					
4-7	Modem types available for reception					
	The setting of these bits is used to inform the transmitting terminal of the available modem type for the machine in receive mode.					
	If V.34 is not selected, V.8 protocol must be disabled manually.					
	Cross reference					
	V.8 protocol on/off - G3 switch 03, bit 2					
		Bit 7	Bit 6	Bit 5	Bit 4	Types
		0	0	0	1	V.27ter
		0	0	1	0	V.27ter, V.29
	0	0	1	1	V.27ter, V.29, V.33	
	0	1	0	0	V.27ter, V.29, V.17/V.33	
	0	1	0	1	V.27ter, V.29, V.17/V33, V.34	
	Other settings - Not used					

G3 Switch 07 (SP No. 1-105-008)						
No	Function			Comments		
0-1	PSTN cable equalizer (tx mode: Internal)			Use a higher setting if there is signal loss at higher frequencies because of the length of wire between the modem and the telephone exchange.		
	Bit 1	Bit 0	Setting	Use the dedicated transmission parameters for specific receivers. Also, try using the cable equalizer if one or more of the following symptoms occurs. Communication error		
	0	0	None			
	0	1	Low			
	1	0	Medium			
	1	1	High			

				Modem rate fallback occurs frequently. <b>Note</b> <ul style="list-style-type: none"> <li>This setting is not effective in V.34 communications.</li> </ul>
2-3	PSTN cable equalizer (rx mode: Internal)			Use a higher setting if there is signal loss at higher frequencies because of the length of wire between the modem and the telephone exchange.  Also, try using the cable equalizer if one or more of the following symptoms occurs.  Communication error with error codes such as 0-20, 0-23, etc.  Modem rate fallback occurs frequently.  <b>Note</b> <ul style="list-style-type: none"> <li>This setting is not effective in V.34 communications.</li> </ul>
	Bit 3	Bit 2	Setting	
	0	0	None	
	0	1	Low	
	1	0	Medium	
	1	1	High	
4	PSTN cable equalizer (V.8/V.17 rx mode: External) 0: Disabled 1: Enabled			Keep this bit at "1".
5-7	Not used			Do not change the settings.

**G3 Switch 08** - Not used (do not change the settings)

**G3 Switch 09** - Not used (do not change the settings)

**G3 Switch 0A (SP No. 1-105-011)**

No	Function			Comments
0-1	Maximum allowable carrier drop during image data reception			These bits set the acceptable modem carrier drop time.  Try a longer setting if error code 0-22 is frequent.
	Bit 1	Bit 0	Value (ms)	
	0	0	200	

	0	1	400	
	1	0	800	
	1	1	Not used	
2	Select cancellation of high-speed RX if carrier signal lost while receiving 0: Off 1: On			This switch setting determines if high-speed receiving ends if the carrier signal is lost when receiving during non-ECM mode
3	Not used			Do not change the settings
4	Maximum allowable frame interval during image data reception. 0: 5 s 1: 13 s			This bit set the maximum interval between EOL (end-of-line) signals and the maximum interval between ECM frames from the other end. Try using a longer setting if error code 0-21 is frequent.
5	Not used			Do not change the settings.
6	Reconstruction time for the first line in receive mode 0: 6 s 1: 12 s			When the sending terminal is controlled by a computer, there may be a delay in receiving page data after the local machine accepts set-up data and sends CFR. This is outside the T.30 recommendation. But, if this delay occurs, set this bit to 1 to give the sending machine more time to send data. Refer to error code 0-20. ITU-T T.30 recommendation: The first line should come within 5 s of CFR.
7	Not used			Do not change the settings.

**G3 Switch 0B** Not used (do not change the settings).

**G3 Switch 0C** Not used (do not change the settings).

**G3 Switch 0D** Not used (do not change the settings).

#### G3 Switch 0E (SP No. 1-105-015)

No	Function	Comments
----	----------	----------

0-7	Set CNG send time interval Some machines on the receiving side may not be able to automatically switch the 3-second CNG interval.	
	High order bit	3000-2250ms: 3000-50xNms 3000 – 50 x Nms OF (3000 ms) <= N <= FF (2250 ms)
	Low order bit	00-0E(3000-3700ms: 3000+50xNms 3000 – 50 x Nms OF (3000 ms) <= N <= 0F (3700 ms)

4

G3 Switch 0F (SP No. 1-105-016)		
No	Function	Comments
0	Alarm when an error occurred in Phase C or later 0: Disabled 1: Enabled	If the customer wants to hear an alarm after each error communication, change this bit to "1".
1	Alarm when the handset is off-hook at the end of communication 0: Disabled 1: Enabled	If the customer wants to hear an alarm if the handset is off-hook at the end of fax communication, change this bit to "1".
2-7	Not used	Do not change the settings.

### G3-2 and G3-3 Switches

These switches require an optional G3 interface unit.

G3-3 switches are the same as for G3-2 switches.

G3-2 Switch 00 (SP No. 1-106-001)				
No	Function			Comments
0 1	Monitor speaker during communication (tx and rx)			(0, 0): The monitor speaker is disabled all through the communication.
	Bit 1	Bit 0	Setting	
	0	0	Disable	(0, 1): The monitor speaker is on up to phase B in the T.30 protocol.



	0	1	Up to Phase B	(1, 0): Used for testing. The monitor speaker is on all through the communication. Make sure that you reset these bits after testing.
	1	0	All the time	
	1	1	Not used	
2	Monitor speaker during memory transmission 0: Disabled 1: Enabled			1: The monitor speaker is enabled during memory transmission.
3-7	Not used			Do not change the settings.

#### G3-2 Switch 01 (SP No. 1-106-002)

No	Function	Comments
0-3	Not used	Do not change the settings.
4	DIS frame length 0: 10 bytes 1: 4 bytes	1: The bytes in the DIS frame after the 4th byte will not be transmitted (set to 1 if there are communication problems with PC-based faxes which cannot receive the extended DIS frames).
5	Not used	Do not change the setting.
6	Forbid CED/AMsam output 0: Off 1: On (Forbid output)	Do not change this setting (Default: 0: Off), unless communication problem is caused by a CED or ANSAm transmission.
7	Not used	Do not change the setting.

#### G3-2 Switch 02 (SP No. 1-106-003)

No	Function	Comments
0	G3 protocol mode used 0: Standard and non-standard 1: Standard only	Change this bit to 1 only when the other end can only communicate with machines that send T.30-standard frames only.  1: Disables NSF/NSS signals (these are used in non-standard mode communication)
1-4	Not used	Do not change the settings.

5	Use of modem rate history for transmission using Quick/Speed Dials 0: Disabled 1: Enabled	0: Communications using Quick/Speed Dials always start from the highest modem rate. 1: The machine refers to the modem rate history for communications with the same machine when determining the most suitable rate for the current communication.
6	Not Used	Do not change the settings.
7	Short preamble 0: Disabled 1: Enabled	Refer to Appendix B in the Group 3 Facsimile Manual for details about Short Preamble.

4

G3-2 Switch 03 (SP No. 1-106-004)		
No	Function	Comments
0	DIS detection number (Echo countermeasure) 0: 1 1: 2	0: The machine will hang up if it receives the same DIS frame twice. 1: Before sending DCS, the machine will wait for the second DIS which is caused by echo on the line.
1	Not Used	Do not change the settings.
2	V.8 protocol 0: Disabled 1: Enabled	0: V.8/V.34 communications will not be possible. <b>Note</b> <ul style="list-style-type: none"> <li>Do not set to 0 unless the line condition is always bad enough to slow down the data rate to 14.4 kbps or lower.</li> </ul>
3	ECM frame size 0: 256 bytes 1: 64 bytes	Keep this bit at "0" in most cases.
4	CTC transmission conditions 0: After one PPR signal received 1: After four PPR signals received (ITU-T standard)	0: When using ECM in non-standard (NSF/NSS) mode, the machine sends a CTC to drop back the modem rate after receiving a PPR, if the following condition is met in communications at 14.4, 12.0, 9.6, and 7.2 kbps. $\sqrt{N_{\text{Transmit}}} \leq N_{\text{Resend}}$ <p><math>N_{\text{transmit}}</math> = Number of transmitted frames  <math>N_{\text{resend}}</math> = Number of frames to be retransmitted</p>

		1: When using ECM, the machine sends a CTC to drop back the modem rate after receiving four PPRs. PPR, CTC: These are ECM protocol signals. This bit is not effective in V.34 communications.
5	Modem rate used for the next page after receiving a negative code (RTN or PIN) 0: No change 1: Fallback	1: The machine's tx modem rate will fall back before sending the next page if a negative code is received. This bit is ignored if ECM is being used.
6	Not used	Do not change the settings
7	Select detection of reverse polarity in ringing 0: Off 1: On	This switch is used to prevent reverse polarity in ringing on the phone line (applied to PSTN-G3 ringing). Do not change this setting 0: No detection (Outside Japan) 1: Detection (Inside Japan only)

#### G3-2 Switch 04 (SP No. 1-106-005)

No	Function	Comments
0-3	Training error detection threshold	0 - F (Hex); 0 - 15 bits If the number of error bits in the received TCF is below this threshold, the machine informs the sender that training has succeeded.
4-7	Not used	Do not change the settings.

#### G3-2 Switch 05 (SP No. 1-106-006)

No	Function					Comments
0-3	Initial Tx modem rate (kbps)					These bits set the initial starting modem rate for transmission.
	Bit 3	Bit 2	Bit 1	Bit 0	kbps	Use the dedicated transmission parameters if you need to change this for specific receivers.
	0	0	0	1	2.4	If a modem rate 14.4 kbps or slower is selected, V.8 protocol should be disabled manually.
	0	0	1	0	4.8	
	0	0	1	1	7.2	Cross reference V.8 protocol on/off - G3 switch 03, bit 2

	0	1	0	0	9.6	
	0	1	0	1	12.0	
	0	1	1	0	14.4	
	0	1	1	1	16.8	
	1	0	0	0	19.2	
	1	0	0	1	21.6	
	1	0	1	0	24.0	
	1	0	1	1	26.4	
	1	1	0	0	28.8	
	1	1	0	1	31.2	
Other settings - Not used						
4-5	Initial modem type for 9.6 k or 7.2 kbps.					These bits set the initial modem type for 9.6 and 7.2 kbps, if the initial modem rate is set at these speeds.
	Bit 5	Bit 4	Setting			
	0	0	V.29			
	0	1	V.17			
	1	0	V.34			
1	1	Not used				
6-7	Not used				Do not change the settings.	

G3-2 Switch 06 (SP No. 1-106-007)						
No	Function					Comments
0-3	Initial Rx modem rate(kbps)					These bits set the initial starting modem rate for reception. Use a lower setting if high speeds pose problems during reception. If a modem rate 14.4 kbps or slower is selected, V.8 protocol should be disabled manually.
	Bit 3	Bit 2	Bit 1	Bit 0	kbps	
	0	0	0	1	2.4	
	0	0	1	0	4.8	
	0	0	1	1	7.2	

	0	1	0	0	9.6	Cross reference V.8 protocol on/off - G3 switch 03, bit2
	0	1	0	1	12.0	
	0	1	1	0	14.4	
	0	1	1	1	16.8	
	1	0	0	0	19.2	
	1	0	0	1	21.6	
	1	0	1	0	24.0	
	1	0	1	1	26.4	
	1	1	0	0	28.8	
	1	1	0	1	31.2	
	Other settings - Not used					
4-7	<p>Modem types available for reception</p> <p>The setting of these bits is used to inform the transmitting terminal of the available modem type for the machine in receive mode.</p> <p>If V.34 is not selected, V.8 protocol must be disabled manually.</p> <p>Cross reference</p> <p>V.8 protocol on/off - G3 switch 03, bit 2</p>					
	Bit 7	Bit 6	Bit 5	Bit 4	Types	
	0	0	0	1	V.27ter	
	0	0	1	0	V.27ter	
	0	0	1	1	V.27ter	
	0	1	0	0	V.27ter	
	0	1	0	1	V.27ter	
	Other settings - Not used					

G3-2 Switch 07 (SP No. 1-106-008)		
No	Function	Comments

0-1	PSTN cable equalizer (tx mode: Internal)			<p>Use a higher setting if there is signal loss at higher frequencies because of the length of wire between the modem and the telephone exchange.</p> <p>Use the dedicated transmission parameters for specific receivers.</p> <p>Also, try using the cable equalizer if one or more of the following symptoms occurs.</p> <p>Communication error</p> <p>Modem rate fallback occurs frequently.</p> <p><b>Note</b></p> <ul style="list-style-type: none"> <li>This setting is not effective in V.34 communications.</li> </ul>
	Bit 1	Bit 0	Setting	
	0	0	None	
	0	1	Low	
	1	0	Medium	
	1	1	High	
2-3	PSTN cable equalizer (rx mode: Internal)			<p>Use a higher setting if there is signal loss at higher frequencies because of the length of wire between the modem and the telephone exchange.</p> <p>Also, try using the cable equalizer if one or more of the following symptoms occurs.</p> <p>Communication error with error codes such as 0-20, 0-23, etc.</p> <p>Modem rate fallback occurs frequently.</p> <p><b>Note</b></p> <ul style="list-style-type: none"> <li>This setting is not effective in V.34 communications.</li> </ul>
	Bit 3	Bit 2	Setting	
	0	0	None	
	0	1	Low	
	1	0	Medium	
	1	1	High	
4	PSTN cable equalizer (V.8/V.17 rx mode: External) 0: Disabled 1: Enabled			Keep this bit at "1".
5-7	Not used			Do not change the settings.

G3-2 Switch 08 - Not used (do not change the settings)

G3-2 Switch 09 - Not used (do not change the settings)

G3-2 Switch 0A (SP No. 1-106-011)				
No	Function			Comments
0-1	Maximum allowable carrier drop during image data reception			<p>These bits set the acceptable modem carrier drop time.</p> <p>Try a longer setting if error code 0-22 is frequent.</p>
	Bit 1	Bit 0	Value (ms)	
	0	0	200	
	0	1	400	
	1	0	800	
	1	1	Not used	
2	Select cancellation of high-speed RX if carrier signal lost while receiving 0: Off 1: On			This switch setting determines if high-speed receiving ends if the carrier signal is lost when receiving during non-ECM mode
3	Not used			Do not change the settings
4	Maximum allowable frame interval during image data reception. 0: 5 s 1: 13 s			<p>This bit set the maximum interval between EOL (end-of-line) signals and the maximum interval between ECM frames from the other end.</p> <p>Try using a longer setting if error code 0-21 is frequent.</p>
5	Not used			Do not change the settings.
6	Reconstruction time for the first line in receive mode 0: 6 s 1: 12 s			<p>When the sending terminal is controlled by a computer, there may be a delay in receiving page data after the local machine accepts set-up data and sends CFR. This is outside the T.30 recommendation. But, if this delay occurs, set this bit to 1 to give the sending machine more time to send data.</p> <p>Refer to error code 0-20.</p> <p>ITU-T T.30 recommendation: The first line should come within 5 s of CFR.</p>
7	Not used			Do not change the settings.

**G3-2 Switch 0B**- Not used (do not change the settings)

**G3-2 Switch 0C**- Not used (do not change the settings)

**G3-2 Switch 0D** - Not used (do not change the settings)

**G3-2 Switch 0E** - Not used (do not change the settings)

**G3-2 Switch 0F** - Not used (do not change the settings)

## G4 Internal Switches

### 4

The G4 internal switches (SW00 to 1F) are displayed but do not change these settings.

## G4 Parameter Switches

The G4 parameter switches (SW00 to 0F) are displayed but do not change these settings.

## IP Fax Switches

IP Fax Switch 00 (SP No. 1-111-001)		
No.	Function	Comments
0	Not used	Do not change this setting.
1	IP Fax Transport 0: TCP, 1: UDP	Selects TCP or UDP protocol for IP-Fax
2	IP Fax single port selection 0: OFF, 1: ON (enable)	Selects single data port.
3	IP Fax double ports (single data port) selection 0: OFF, 1: ON (enable)	Selects whether IP-Fax uses a double port.
4	IP Fax Gatekeeper 0: OFF, 1: ON (enable)	Enables/disables the gatekeeper for IP-Fax.
5	IP Fax T30 bit signal reverse 0: LSB first, 1: MSB first	Reverses the T30 bit signal.



6	IP Fax max bit rate setting 0: Not affected, 1: Affected	When "0" is selected, the max bit rate does not affect the value of the DIS/DCS. When "1" is selected, the max bit rate affects the value of the DIS/DCS.
7	IP Fax received telephone number confirmation 0: No confirmation, 1: Confirmation	When "0" is selected, fax data is received without checking the telephone number. When "1" is selected, fax data is received only when confirming that the telephone number from the sender matches the registered telephone number in this machine. If this confirmation fails, the line is disconnected.

IP Fax Switch 01 (SP No. 1-111-002)					
No.	Function				Comments
0-3	IP Fax delay level setting Selects the acceptable delay level. Level 0 is the highest quality Default is "0000" (level 0).				
	Bit 3	Bit 2	Bit 1	Bit 0	
	0	0	0	0	Level 0
	0	0	0	1	Level 1
	0	0	1	0	Level 2
	0	0	1	1	Level 3
4-7	IP Fax preamble wait time setting				Selects the preamble wait time. [00 to 0f] There are 16 values in this 4-bit binary switch combination. Waiting time: set value level x 100 ms Max: 0f (1500 ms) Min: 00 (No wait time) The default is "0000" (00H).

## IP Fax Switch 02 (SP No. 1-111-003)

No.	Function	Comments
0	IP Fax bit signal reverse setting 0: Maker code setting 1: Internal bit switch setting	When "0" is selected, the bit signal reverse method is decided by the maker code. When "1" is selected, the bit signal reverse method is decided by the internal bit switch. (When communicating between IP Fax devices, LSB first is selected.)
1	IP Fax transmission speed setting 0: Modem speed 1: No limitation	Selects the transmit speed for IP Fax communication.
2	SIP transport setting 0: TCP 1: UDP	This bit switch sets the transport that has priority for receiving IP Fax data. This function is activated only when the sender has both TCP and UDP.
3-7	Not used	Do not change these settings.

IP Fax Switch 03 (SP No. 1-111-004)		
No.	Function	Comments
0	Effective field limitation for G3 standard function information 0: OFF, 1: 4byte (DIS)	Limits the effective field for standard G3 function information.
1	Switching between G3 standard and G3 non standard 0: Enable switching 1: G3 standard only	Enables/disables switching between G3 standard and G3 non-standard.
2	AI modem rate function 0: OFF, 1: ON (enable)	Enables/disables the AI modem rate.
3	ECM frame size selection at transmitting 0: 256byte, 1: 64byte	Selects the ECM frame size for sending.
4	DIS detection times for echo prevention 0: 1 time, 1: 2 times	Sets the number of times for DIS to detect echoes.

5	CTC transmission selection 0: PPRx1 1: PPRx4	When "0" is selected, the transmission condition is decided by error frame numbers. When "1" is selected, the transmission condition is based on the ITU-T method.
6	Shift down setting at receiving negative code 0: OFF, 1: ON	Selects whether to shift down when negative codes are received.
7	Not used	Do not change this setting.

#### IP Fax Switch 04 (SP No. 1-111-005)

No.	Function	Comments
0-3	TCF error threshold	Sets the TCF error threshold level. [00 to 0f] The default is "1111" (0fH).
4-7	Not used	Do not change these settings.

#### IP Fax Switch 05 (SP No. 1-111-006)

No.	Function					Comments
0-3	Modem bit rate setting for transmission (kbps)					Sets the modem bit rate for transmission. The default is "0110" (14.4K bps).
	Bit 3	Bit 2	Bit 1	Bit 0	kbps	
	0	0	0	1	2.4	
	0	0	1	1	4.8	
	0	0	1	1	7.2	
	0	1	0	0	9.6	
	0	1	0	1	12.0	
4-5	Modem setting for transmission					Sets the modem type for transmission. The default is "00" (V29).
	Bit 5		Bit 4		Types	
	0		0		V29	

	0	1	V17	
	1	0	Not used	
	1	1	Not used	
6-7	Not used			Do not change these settings.

**IP Fax Switch 06 (SP No. 1-111-007)**

No.	Function				Comments
0-3	Modem bit rate setting for reception Sets the modem bit rate for reception. The default is "0110" (14.4K bps).				
4-7	Modem setting for reception Sets the modem type for reception. The default is "0100" (V.27ter, V.29, V17).				
	Bit 7	Bit 6	Bit 5	Bit 4	Types
	0	0	0	1	V.27ter
	0	0	1	0	V.27ter, V.29
	0	0	1	1	V.27ter, V.29, V.33
	0	1	0	0	V.27ter, V.29, V.17/V.33
Other settings - Not used					

**IP Fax Switch 07 (SP No. 1-111-008)**

No.	Function		Comments
0	TSI information 0: Not added, 1: Added		Adds or does not add TSI information to NSS(S).
1	DCN transmission setting at T1 timeout 0: Not transmitted 1: Transmitted		Transmits or does not transmit DCN at T1 timeout.
2	Not used		Do not change this setting.
3	Hang up setting at DIS reception disabled 0: No hang up		Sets whether the machine disconnects after DIS reception.

	1: Hang up after transmitting DCN	
4	Number of times for training 0: 1 time, 1: 2 times	Selects the number of times training is done at the same bit rate.
5	Space CSI transmission setting at no CSI registration 0: Not transmitted 1: Transmitted	When "0" is selected, frame data is enabled. When "1" is selected, the transmitted data is all spaces.
6-7	Not used	Do not change these settings.

#### IP Fax Switch 08 (SP No. 1-111-009)

No.	Function			Comments
0-1	T1 timer adjustment			Adjusts the T1 timer. The default is "00" (35 seconds).
	Bit 1	Bit 0		
	0	0	35 s	
	0	1	40 s	
	1	0	50 s	
	1	1	60 s	
2-3	T4 timer adjustment			Adjust the T4 timer. The default is "00" (3 seconds).
	Bit 3	Bit 2		
	0	0	3 s	
	0	1	3.5 s	
	1	0	4 s	
	1	1	5 s	
4-5	T0 timer adjustment			Adjusts the fail safe timer. This timer sets the interval between "setup" data transmission and T.38 phase decision. If your destination return is late on the network or G3 fax return is late, adjust the longer interval timer. The default is "00" (75 seconds).
	Bit 5	Bit 4		
	0	0	75 s	
	0	1	120 s	

	1	0	180 s	
	1	1	240 s	
6-7	Not used			Do not change these settings.

**IP Fax Switch 09 (SP No. 1-111-010)**

No.	Function	Comments
0	Network I/F setting for SIP connection 0: IPv4 1: IPv6.	Selects the connection type (IPV4 or IPV6) to connect to the SIP server.
1	Network I/F setting for Fax communication 0: Same setting as SIP server connection 1: Automatic setting	0: The I/F setting for fax communication follows the setting for SIP server connection. 1: The negotiation between the SIP server and the device decides whether IPv4 or IPv6 is used for the I/F setting for fax communication.
2	Record-route setting 0: Disable 1: Enable	0: Disables the record-route function of the SIP server. 1: Enables the record-route function of the SIP server.
3-7	Not used.	
Do not change these settings.		

## NCU Parameters

The following tables give the RAM addresses and the parameter calculation units that the machine uses for ringing signal detection and automatic dialing. The factory settings for each country are also given. Most of these must be changed by RAM read/write (SP2-102), but some can be changed using NCU Parameter programming (SP2-103, 104 and 105); if SP2-103, 104 and 105 can be used, this will be indicated in the Remarks column. The RAM is programmed in hex code unless (BCD) is included in the Unit column.

### ↓ Note

- The following addresses describe settings for the standard NCU.
- Change the fourth digit from "5" to "6" (e.g. 680500 to 680600) for the settings for the first optional G3 interface unit and from "5" to "7" (e.g. 680700) for the settings for the second optional G3 interface unit.

4

Address	Function					
680500	Country/Area code for NCU parameters					
	Use the Hex value to program the country/area code directly into this address, or use the decimal value to program it using SP2-103-001					
	<b>Country /Area</b>	<b>Decimal</b>	<b>Hex</b>	<b>Country /Area</b>	<b>Decimal</b>	<b>Hex</b>
	France	00	00	USA	17	11
	Germany	01	01	Asia	18	12
	UK	02	02	Hong Kong	20	14
	Italy	03	03	South Africa	21	15
	Austria	04	04	Australia	22	16
	Belgium	05	05	New Zealand	26	17
	Denmark	06	06	Singapore	24	18
	Finland	07	07	Malaysia	25	19
	Ireland	08	08	China	26	1A
	Norway	09	09	Taiwan	27	1B
Sweden	10	0A	Korea	28	1C	

Address	Function					
	Switzerland	11	0B	Turkey	32	20
	Portugal	12	0C	Greece	33	21
	Holland	13	0D	Hungary	34	22
	Spain	14	0E	Czech	35	23
	Israel	15	0F	Poland	36	24

4

Address	Function	Unit	Remarks
680501	Line current detection time	20 ms	Line current detection is disabled. Line current is not detected if 680501 contains FF.
680502	Line current wait time		
680503	Line current drop detect time		
680504	PSTN dial tone frequency upper limit (high byte)	Hz (BCD)	If both addresses contain FF (H), tone detection is disabled.
680505	PSTN dial tone frequency upper limit (low byte)		
680506	PSTN dial tone frequency lower limit (high byte)	Hz (BCD)	If both addresses contain FF (H), tone detection is disabled.
680507	PSTN dial tone frequency lower limit (low byte)		
680508	PSTN dial tone detection time	20 ms	If 680508 contains FF(H), the machine pauses for the pause time (address 68050D / 68050E). Italy: See Note 2.
680509	PSTN dial tone reset time (LOW)		
68050A	PSTN dial tone reset time (HIGH)		
68050B	PSTN dial tone continuous tone time		
68050C	PSTN dial tone permissible drop time		
68050D	PSTN wait interval (LOW)		
68050E	PSTN wait interval (HIGH)		
68050F	PSTN ring-back tone detection time	20 ms	Detection is disabled if this contains FF.



Address	Function	Unit	Remarks
680510	PSTN ring-back tone off detection time	20 ms	-
680511	PSTN detection time for silent period after ring-back tone detected (LOW)	20 ms	-
680512	PSTN detection time for silent period after ring-back tone detected (HIGH)	20 ms	-
680513	PSTN busy tone frequency upper limit (high byte)	Hz (BCD)	If both addresses contain FF (H), tone detection is disabled.
680514	PSTN busy tone frequency upper limit (low byte)		
680515	PSTN busy tone frequency lower limit (high byte)	Hz (BCD)	If both addresses contain FF (H), tone detection is disabled.
680516	PSTN busy tone frequency lower limit (low byte)		
680517	PABX dial tone frequency upper limit (high byte)	Hz (BCD)	If both addresses contain FF (H), tone detection is disabled.
680518	PABX dial tone frequency upper limit (low byte)		
680519	PABX dial tone frequency lower limit (high byte)	Hz (BCD)	If both addresses contain FF (H), tone detection is disabled.
68051A	PABX dial tone frequency lower limit (low byte)		
68051B	PABX dial tone detection time	20 ms	If 68051B contains FF, the machine pauses for the pause time (680520 / 680521).
68051C	PABX dial tone reset time (LOW)		
68051D	PABX dial tone reset time (HIGH)		
68051E	PABX dial tone continuous tone time		
68051F	PABX dial tone permissible drop time		
680520	PABX wait interval (LOW)		
680521	PABX wait interval (HIGH)		

Address	Function	Unit	Remarks
680522	PABX ringback tone detection time	20 ms	If both addresses contain FF (H), tone detection is disabled.
680523	PABX ringback tone off detection time	20 ms	
680524	PABX detection time for silent period after ringback tone detected (LOW)	20 ms	If both addresses contain FF (H), tone detection is disabled.
680525	PABX detection time for silent period after ringback tone detected (HIGH)	20 ms	
680526	PABX busy tone frequency upper limit (high byte)	Hz (BCD)	If both addresses contain FF (H), tone detection is disabled.
680527	PABX busy tone frequency upper limit (low byte)		
680528	PABX busy tone frequency lower limit (high byte)	Hz (BCD)	If both addresses contain FF (H), tone detection is disabled.
680529	PABX busy tone frequency lower limit (low byte)		
68052A	Busy tone ON time: range 1	20 ms	-
68052B	Busy tone OFF time: range 1		
68052C	Busy tone ON time: range 2		
68052D	Busy tone OFF time: range 2		
68052E	Busy tone ON time: range 3	20 ms	
68052F	Busy tone OFF time: range 3		
680530	Busy tone ON time: range 4		
680531	Busy tone OFF time: range 4		
680532	Busy tone continuous tone detection time		
680533	<p>Busy tone signal state time tolerance for all ranges, and number of cycles required for detection (a setting of 4 cycles means that ON-OFF-ON or OFF-ON-OFF must be detected twice).</p> <p>Tolerance (<math>\pm</math>)</p> <p>Bit 1: 0, Bit 0: 0 = 75% Bits 2 and 3 must always be kept at 0.</p>		

Address	Function	Unit	Remarks
	Bit 1: 0, Bit 0: 0 = 50% Bits 2 and 3 must always be kept at 0. Bit 1: 0, Bit 0: 0 = 25% Bit 1: 0, Bit 0: 0 = 12.5% Bits 7, 6, 5, 4 - number of cycles required for cadence detection		
680534	International dial tone frequency upper limit (high byte)	Hz (BCD)	If both addresses contain FF (H), tone detection is disabled.
680535	International dial tone frequency upper limit (low byte)		
680536	International dial tone frequency lower limit (high byte)	Hz (BCD)	If both addresses contain FF (H), tone detection is disabled.
680537	International dial tone frequency lower limit (low byte)		
680538	International dial tone detection time	20 ms	If 680538 contains FF, the machine pauses for the pause time (68053D / 68053E). Belgium: See Note 2.
680539	International dial tone reset time (LOW)		
68053A	International dial tone reset time (HIGH)		
68053B	International dial tone continuous tone time		
68053C	International dial tone permissible drop time		
68053D	International dial wait interval (LOW)		
68053E	International dial wait interval (HIGH)		
68053F	Country dial tone upper frequency limit (HIGH)	Hz (BCD)	If both addresses contain FF (H), tone detection is disabled.
680540	Country dial tone upper frequency limit (LOW)		
680541	Country dial tone lower frequency limit (HIGH)		If both addresses contain FF (H), tone detection is disabled.
680542	Country dial tone lower frequency limit (LOW)		

Address	Function	Unit	Remarks
680543	Country dial tone detection time	20 ms	If 680543 contains FF, the machine pauses for the pause time (680548 / 680549).
680544	Country dial tone reset time (LOW)		
680545	Country dial tone reset time (HIGH)		
680546	Country dial tone continuous tone time	-	-
680547	Country dial tone permissible drop time	20 ms	-
680548	Country dial wait interval (LOW)		
680549	Country dial wait interval (HIGH)		
68054A	Time between opening or closing the DO relay and opening the OHDI relay	1 ms	See Notes 3, 6 and 8. SP2-103-012 (parameter 11).
68054B	Break time for pulse dialing	1 ms	See Note 3. SP2-103-013 (parameter 12).
68054C	Make time for pulse dialing	1 ms	See Note 3. SP2-103-014 (parameter 13).
68054D	Time between final OHDI relay closure and DO relay opening or closing	1 ms	See Notes 3, 6 and 8. SP2-103-015 (parameter 14). This parameter is only valid in Europe.
68054E	Minimum pause between dialed digits (pulse dial mode)	20 ms	See Note 3 and 8. SP2-103-016 (parameter 15).
68054F	Time waited when a pause is entered at the operation panel		SP2-103-017 (parameter 16). See Note 3.
680550	DTMF tone on time	1 ms	SP2-103-018 (parameter 17).
680551	DTMF tone off time		SP2-103-019 (parameter 18).

Address	Function	Unit	Remarks
680552	Tone attenuation level of DTMF signals while dialing	-N x 0.5 –3.5 dBm	SP2-103-020 (parameter 19). See Note 5.
680553	Tone attenuation value difference between high frequency tone and low frequency tone in DTMF signals	-dBm x 0.5	SP2-103-021 (parameter 20). The setting must be less than –5dBm, and should not exceed the setting at 680552h above. See Note 5.
680554	PSTN: DTMF tone attenuation level after dialling	-N x 0.5 –3.5 dBm	SP2-103-022 (parameter 21). See Note 5.
680555	ISDN: DTMF tone attenuation level after dialling	-dBm x 0.5	See Note 5
680556	Not used	-	Do not change the settings.
680557	Time between 68054Dh (NCU parameter 14) and 68054Eh (NCU parameter 15)	1 ms	This parameter takes effect when the country code is set to France.
680558	Not used	-	Do not change the setting.
680559	Grounding time (ground start mode)	20 ms	The Gs relay is closed for this interval.
68055A	Break time (flash start mode)	1 ms	The OHDI relay is open for this interval.
68055B	International dial access code (High)	BCD	For a code of 100: 68055B - F1 68055C - 00
68055C	International dial access code (Low)		
68055D	PSTN access pause time	20 ms	This time is waited for each pause input after the PSTN access code. If this address contains FF[H], the pause time stored in address 68054F is used.

Address	Function	Unit	Remarks
			Do not set a number more than 7 in the UK.
68055E	Progress tone detection level, and cadence detection enable flags	Bit 7: 0, Bit 6: 0, Bit 5: 0 = -25.0 dBm Bit 7: 0, Bit 6: 0, Bit 5: 1 = -35.0 dBm Bit 7: 0, Bit 6: 1, Bit 5: 0 = -30.0 dBm Bit 7: 1, Bit 6: 0, Bit 5: 0 = -40.0 dBm Bit 7: 1, Bit 6: 1, Bit 5: 0 = -49.0 dBm Bits 2, 0 - See Note 2.	
68055F To 680564	<b>Not used</b>	-	Do not change the settings.
680565	Long distance call prefix (HIGH)	BCD	For a code of 0: 680565 – FF 680566 - FF
680566	Long distance call prefix (LOW)	BCD	
680567 to 680571	<b>Not used</b>	-	Do not change the settings.
680572	Acceptable ringing signal frequency: range 1, upper limit	1000/ N (Hz).	SP2-103-003 (parameter 02).
680573	Acceptable ringing signal frequency: range 1, lower limit		SP2-103-004 (parameter 03).
680574	Acceptable ringing signal frequency: range 2, upper limit		SP2-103-005 (parameter 04).
680575	Acceptable ringing signal frequency: range 2, lower limit		SP2-103-006 (parameter 05).
680576	Number of rings until a call is detected	1	SP2-103-007 (parameter 06). The setting must not be zero.
680577	Minimum required length of the first ring	20 ms	See Note 4.

Address	Function	Unit	Remarks
			SP2-103-008 (parameter 07).
680578	Minimum required length of the second and subsequent rings	20 ms	SP2-103-009 (parameter 08).
680579	Ringing signal detection reset time (LOW)	20 ms	SP2-103-010 (parameter 09).
68057A	Ringing signal detection reset time (HIGH)		SP2-103-011 (parameter 10).
68057B to 680580	<b>Not used</b>	-	Do not change the settings.
680581	Interval between dialing the last digit and switching the Oh relay over to the external telephone when dialing from the operation panel in handset mode.	20 ms	Factory setting: 500 ms
680582	Bits 0 and 1 - Handset off-hook detection time Bit 1:0, Bit 0: 0 = 200 ms Bit 1:0, Bit 0: 1 = 800 ms Other Not used Bits 2 and 3 - Handset on-hook detection time Bit 3: 0, Bit 2: 0 = 200 ms Bit 3: 0, Bit 2: 1 = 800 ms Other Not used Bits 4 to 7 - <b>Not used</b>		-
680583 To 6805A0	<b>Not used</b>	-	Do not change the settings.
6805A1	Acceptable CED detection frequency upper limit (high byte)	BCD (Hz)	If both addresses contain FF (H), tone detection is disabled.
6805A2	Acceptable CED detection frequency upper limit (low byte)		

Address	Function	Unit	Remarks
6805A3	Acceptable CED detection frequency lower limit (high byte)	BCD (Hz)	If both addresses contain FF (H), tone detection is disabled.
6805A4	Acceptable CED detection frequency lower limit (low byte)		
6805A5	CED detection time	20 ms ± 20 ms	Factory setting: 200 ms
6805A6	Acceptable CNG detection frequency upper limit (high byte)	BCD (Hz)	If both addresses contain FF (H), tone detection is disabled.
6805A7	Acceptable CNG detection frequency upper limit (low byte)		
6805A8	Acceptable CNG detection frequency lower limit (high byte)	BCD (Hz)	If both addresses contain FF (H), tone detection is disabled.
6805A9	Acceptable CNG detection frequency lower limit (low byte)		
6805AA	<b>Not used</b>	-	Do not change the setting.
6805AB	CNG on time	20 ms	Factory setting: 500 ms
6805AC	CNG off time	20 ms	Factory setting: 3000 ms
6805AD	Number of CNG cycles required for detection	-	The data is coded in the same way as address 680533.
6805AE	<b>Not used</b>	-	Do not change the settings.
6805AF	Acceptable AI short protocol tone (800Hz) detection frequency upper limit (high byte)	Hz (BCD)	If both addresses contain FF (H), tone detection is disabled.
6805B0	Acceptable AI short protocol tone (800Hz) detection frequency upper limit (low byte)		
6805B1	Acceptable AI short protocol tone (800Hz) detection frequency lower limit (high byte)	Hz(BCD)	If both addresses contain FF (H), tone detection is disabled.
6805B2	Acceptable AI short protocol tone (800Hz) detection frequency lower limit (low byte)		



Address	Function	Unit	Remarks
6805B3	Detection time for 800 Hz AI short protocol tone	20 ms	Factory setting: 360 ms
6805B4	PSTN: Tx level from the modem	-N – 3 dBm	SP2-103-002 (parameter 01).
6805B5	PSTN: 1100 Hz tone transmission level	- N 6805B4 - 0.5N 6805B5 –3.5 (dB) See Note 7.	
6805B6	PSTN: 2100 Hz tone transmission level	- N6805B4 - 0.5N 6805B6 –3 (dB) See Note 7.	
6805B7	PABX: Tx level from the modem	- dBm	
6805B8	PABX: 1100 Hz tone transmission level	- N 6805B7 - 0.5N 6805B8 (dB)	
6805B9	PABX: 2100 Hz tone transmission level	- N 6805B7 - 0.5N 6805B9 (dB)	
6805BD	Modem turn-on level (incoming signal detection level)	-37-0.5N (dBm)	
6805BE to 6805C6	<b>Not used</b>	-	Do not change the settings.
6805C7	Bits 0 to 3 – <b>Not used</b> Bit 4 = V.34 protocol dump 0: Simple, 1: Detailed (default) Bits 5 to 7 – <b>Not used.</b>		
6805C8 to 6805D9	<b>Not used</b>	-	Do not change the settings.
6805DA	T.30 T1 timer	1 s	
6805E0 bit 3	Maximum wait time for post message	0: 12 s 1: 30 s	1: Maximum wait time for post message (EOP/EOM/MPS) can be changed to 30 s. Change this bit to “1” if communication errors occur frequently during V.17 reception.

Address	Function					Unit	Remarks
6805E3	Voltage setting to detect off-hook for voltage/DP detection for an externally connected line.					0: Auto 1: Fixed V	Do not change these settings
	Here is a summary of the fixed voltage settings (1: Fixed) for an externally connected line.						
	Bit 7	Bit 6	Bit 5	Bit 4	-		
	0	0	0	0	<b>Not used</b>		
	0	0	0	1	2.75 V		
	0	0	1	0	5.5 V		
	1	0	0	0	22 V		
	1	1	1	1	41.25 V		
6805E4	Bit 1 sets the level of the call signal, Bit 3 sets the call signal impedance			Bit 1	0	RT=0 (Low)	-
					1	RT=1 (High)	
				Bit 3	0	RZ=0 (High)	
					1	RZ=1 (Composite)	
6805E5	Bit 0 sets the ring detection method, Bit 1 sets the ring detection method when fixed.			Bit 0	0	Auto	If any setting is changed, select a setting that is higher than the default setting.
					1	Fixed	
				Bit 1	0	Use RDTP	
					1	Use RDTN	
	Here is a summary of the voltages for the detection of off-hook for DP detection.						
	Bit 7	Bit 6	Bit 5	Bit 4	-		
	0	0	0	0	<b>Not used</b>		
0	0	0	1	2.75 V			
0	0	1	0	5.5 V			
1	0	0	0	22 V			

Address	Function				Unit	Remarks
	1	1	1	1	41.25 V	

## NOTES

- If a setting is not required, store FF in the address.
  - Italy and Belgium only  
RAM address 68055E: the lower four bits have the following meaning.  
Bit 2 - 1: International dial tone cadence detection enabled (Belgium)  
Bit 1 - Not used  
Bit 0 - 1: PSTN dial tone cadence detection enabled (Italy)  
If bit 0 or bit 2 is set to 1, the functions of the following RAM addresses are changed.  
680508 (if bit 0 = 1) or 680538 (if bit 2 = 1): tolerance for on or off state duration (%), and number of cycles required for detection, coded as in address 680533.  
68050B (if bit 0 = 1) or 68053B (if bit 2 = 1): on time, hex code (unit = 20 ms)  
68050C (if bit 0 = 1) or 68053C (if bit 2 = 1): off time, hex code (unit = 20 ms)
  - Pulse dial parameters (addresses 68054A to 68054F) are the values for 10 pps. If 20 pps is used, the machine automatically compensates.
  - The first ring may not be detected until 1 to 2.5 wavelengths after the time specified by this parameter.
  - The calculated level must be between 0 and 10.  
The attenuation levels calculated from RAM data are:  
High frequency tone:
    - $-0.5 \times N_{680552/680554} - 3.5$  dBm
    - $-0.5 \times N_{680555}$  dBm
 Low frequency tone:
    - $-0.5 \times (N_{680552/680554} + N_{680553}) - 3.5$  dBm
    - $-0.5 \times (N_{680555} + N_{680553})$  dBm
- Note**
- $N_{680552}$ , for example, means the value stored in address 680552(H)
- 68054A: Europe - Between Ds opening and Di opening, France - Between Ds closing and Di opening  
68054D: Europe - Between Ds closing and Di closing, France - Between Ds opening and Di closing
  - Tone signals which frequency is lower than 1500Hz (e.g., 800Hz tone for AI short protocol) refer to the setting at 6805B5h. Tones which frequency is higher than 1500Hz refer to the setting at 6805B6h.
  - 68054A, 68054D, 68054E: The actual inter-digit pause (pulse dial mode) is the sum of the period specified by the RAM addresses 68054A, 68054D, and 68054E.

## Dedicated Transmission Parameters

There are two sets of transmission parameters: Fax and E-mail

Each Quick Dial Key and Speed Dial Code has eight bytes of programmable parameters allocated to it. If transmissions to a particular machine often experience problems, store that terminal's fax number as a Quick Dial or Speed Dial, and adjust the parameters allocated to that number.

The programming procedure will be explained first. Then, the eight bytes will be described.

### Programming Procedure

4

1. Set the bit 0 of System Bit Switch 00 to 1.
2. Enter Address Book Management mode ([User Tools]> System Settings> Key Operator> Address Book Management).
3. Select the address book that you want to program.
4. For the fax parameter, select "Fax Dest.", for the E-mail parameter, select "E-mail", then press "Start". Make sure that the LED of the Start button lights green.
5. The settings for the switch 00 are now displayed. Press the bit number that you wish to change.
6. To scroll through the parameter switches, either:
7. Select the next switch: press "Next" or Select the previous switch: "Prev." until the correct switch is displayed. Then go back to step 6.
8. After the setting is changed, press "OK".
9. After finishing, reset bit 0 of System Bit Switch 00 to 0.

### Parameters

#### Fax Parameters

The initial settings of the following fax parameters are all FF(H) - all the parameters are disabled.

<b>Switch 00</b>
<b>FUNCTION AND COMMENTS</b>
ITU-T T1 time (for PSTN G3 mode) If the connection time to a particular terminal is longer than the NCU parameter setting, adjust this byte. The T1 time is the value stored in this byte (in hex code), multiplied by 1 second.
<b>Range:</b>

0 to 120 s (00h to 78h)

FFh - The local NCU parameter factory setting is used.

Do not program a value between 79h and FEh.

### Switch 01

No	FUNCTION						COMMENTS
0-4	Tx level						<p>If communication with a particular remote terminal often contains errors, the signal level may be inappropriate. Adjust the Tx level for communications with that terminal until the results are better.</p> <p>If the setting is "Disabled", the NCU parameter 01 setting is used.</p> <p><b>Note</b></p> <ul style="list-style-type: none"> <li>Do not use settings other than listed on the left.</li> </ul>
	Bit4	Bit3	Bit2	Bit1	Bit0		
	0	0	0	0	0	0	
	0	0	0	0	1	-1	
	0	0	0	1	0	-2	
	0	0	0	1	1	-3	
	0	0	1	0	0	-4	
	↓	↓	↓	↓	↓	↓	
	0	1	1	1	1	-15	
	1	1	1	1	1	Disabled	
5-7	<p>Cable equalizer</p> <p>Bit 7: 0, Bit 6: 0, Bit 5: 0 = None</p> <p>Bit 7: 0, Bit 6: 0, Bit 5: 1 = Low</p> <p>Bit 7: 0, Bit 6: 1, Bit 5: 0 = Medium</p> <p>Bit 7: 0, Bit 6: 1, Bit 5: 1 = High</p> <p>Bit 7: 1, Bit 6: 1, Bit 5: 1 = Disabled</p>						<p>Use a higher setting if there is signal loss at higher frequencies because of the length of wire between the modem and the telephone exchange when calling the number stored in this Quick/Speed Dial.</p> <p>Also, try using the cable equalizer if one or more of the following symptoms occurs.</p> <p>Communication error with error codes such as 0-20, 0-23, etc.</p> <p>Modem rate fallback occurs frequently.</p> <p><b>Note</b></p> <ul style="list-style-type: none"> <li>Do not use settings other than listed on the left.</li> </ul> <p>If the setting is "Disabled", the bit switch setting is used.</p>

Switch 02						
No	FUNCTION					COMMENTS
0-3	Initial Tx modem rate					<p>If training with a particular remote terminal always takes too long, the initial modem rate may be too high. Reduce the initial Tx modem rate using these bits.</p> <p>For the settings 14.4 or kbps slower, Switch 04 bit 4 must be changed to 0.</p> <p><b>Note</b></p> <ul style="list-style-type: none"> <li>Do not use settings other than listed on the left. If the setting is "Disabled", the bit switch setting is used.</li> </ul>
	Bit3	Bit2	Bit1	Bit0	bps	
	0	0	0	0	Not used	
	0	0	0	1	2400	
	0	0	1	0	4800	
	0	0	1	1	7200	
	0	1	0	0	9600	
	0	1	0	1	12000	
	0	1	1	0	14400	
	0	1	1	1	16800	
	1	0	0	0	19200	
	1	0	0	1	21600	
	1	0	1	0	24000	
	1	0	1	1	26400	
	1	1	0	0	28800	
	1	1	0	1	31200	
	1	1	1	0	33600	
1	1	1	1	Disabled		
Other settings: <b>Not used</b>						
4-7	<b>Not used</b>					Do not change the settings.

Switch 03		
No	FUNCTION	COMMENTS
0-1	Inch-mm conversion before tx	The machine uses inch-based resolutions for scanning. If "inch only" is selected, the printed copy may be slightly

	Bit 1: 0, Bit 0: 0 = Inch-mm conversion available Bit 1: 0, Bit 0: 1 = Inch only Bit 1: 1, Bit 0: 0 = Not used Bit 1: 1, Bit 0: 1 = Disabled	distorted at the other end if that machine uses mm-based resolutions. If the setting is "Disabled", the bit switch setting is used.
2-3	DIS/NSF detection method Bit 3: 0, Bit 2: 0 = First DIS or NSF Bit 3: 0, Bit 2: 1 = Second DIS or NSF Bit 3: 1, Bit 2: 0 = Not used Bit 3: 1, Bit 2: 1 = Disabled	(0, 1): Use this setting if echoes on the line are interfering with the set-up protocol at the start of transmission. The machine will then wait for the second DIS or NSF before sending DCS or NSS. If the setting is "Disabled", the bit switch setting is used.
4	V.8 protocol 0: Off 1: Disabled	If transmissions to a specific destination always end at a lower modem rate (14,400 bps or lower), disable V.8 protocol so as not to use V.34 protocol. 0: V.34 communication will not be possible. If the setting is "Disabled", the bit switch setting is used.
5	Compression modes available in transmit mode 0: MH only 1: Disabled	This bit determines the capabilities that are informed to the other terminal during transmission. If the setting is "Disabled", the bit switch setting is used.
6-7	ECM during transmission Bit 7: 0, Bit 6: 0 = Off Bit 7: 0, Bit 6: 1 = On Bit 7: 1, Bit 6: 0 = Not used Bit 7: 1, Bit 6: 1 = Disabled	For example, if ECM is switched on but is not wanted when sending to a particular terminal, use the (0, 0) setting. <div style="border: 1px solid blue; border-radius: 10px; padding: 2px; display: inline-block;">  <b>Note</b> </div> <ul style="list-style-type: none"> <li>• V.8/V.34 protocol and JBIG compression are automatically disabled if ECM is disabled.</li> <li>• If the setting is "Disabled", the bit switch setting is used.</li> </ul>

**Switch 04 - Not used** (do not change the settings)

**Switch 05 - Not used** (do not change the settings)

**Switch 06 - Not used** (do not change the settings)

**Switch 07 - Not used** (do not change the settings)

<b>Switch 08 - Not used</b> (do not change the settings)
<b>Switch 09 - Not used</b> (do not change the settings)

### E-mail Parameters

The initial settings of the following e-mail parameters are all "0" (all parameters disabled).

Switch 00		
No	FUNCTION	COMMENTS
0	MH Compression mode for e-mail attachments 0: Off 1: On	Switches MH compression on and off for files attached to e-mails for sending.
1	MR Compression mode for e-mail attachments 0: Off 1: On	Switches MR compression on and off for files attached to e-mails for sending.
2	MMR Compression mode for e-mail attachments 0: Off 1: On	Switches MMR compression on and off for files attached to e-mails for sending.
3-6	<b>Not used</b>	Do not change these settings.
7	Designates the bits to reference for compression method of e-mail attachments 0: Registered (Bit 0 to 6) 1: No registration.	The "0" selection (default) references the settings for Bits 00, 01, 02 above. The "1" selection ignores the selections of Bits 00, 01, 02.

Switch 01		
No	FUNCTION	COMMENTS
0	Original width of e-mail attachment: A4 0: Off	Sets the original width of the e-mail attachment as A4.



	1: On	
1	Original width of e-mail attachment: B4 0: Off 1: On	Sets the original width of the e-mail attachment as B4.
2	Original width of e-mail attachment: A3 0: Off 1: On	Sets the original width of the e-mail attachment as A3.
3-6	<b>Not used</b>	Do not change these settings.
7	Designates the bits to reference for original size of e-mail attachments 0: Registered (Bit 0 to 6) 1: No registration.	The "0" selection (default) references the settings for Bits 00, 01, 02 above. The "1" selection ignores the selections of Bits 00, 01, 02.

Switch 02		
No	FUNCTION	COMMENTS
0	Line resolution of e-mail attachment: 200 x 100 0: Off 1: On	Sets the line resolution of the e-mail attachment as 200 x 100.
1	Line resolution of e-mail attachment: 200 x 200 0: Off 1: On	Sets the line resolution of the e-mail attachment as 200 x 200.
2	Line resolution of e-mail attachment: 200 x 400 0: Off 1: On	Sets the line resolution of the e-mail attachment as 200 x 400.
3	Not used	Do not change these settings.

4	Line resolution of e-mail attachment: 400 x 400 0: Off 1: On	Sets the line resolution of the e-mail attachment as 400 x 400.
5-6	<b>Not used</b>	Do not change these settings.
7	Designates the bits to reference for original size of e-mail attachments 0: Registered (Bit 0 to 6) 1: No registration.	The "0" selection (default) references the settings for Bits 00, 01, 02, 04 above. The "1" selection ignores the selections of Bits 00, 01, 02, 04.

**Switch 03 - Not used** (do not change the settings)

Switch 04		
No	FUNCTION	COMMENTS
0	Full mode address selection 0: Full mode address 1: No full mode (simple mode)	If the other ends have the addresses, which have the full mode function flag ("0"), this machine determines them as full mode standard machines. <ul style="list-style-type: none"> <li>• This machine attaches the "demand of reception confirmation" to a message when transmitting.</li> <li>• This machine updates the reception capability to the address book when receiving.</li> </ul>
1-7	<b>Not used</b>	Do not change these settings.

Switch 05		
No	FUNCTION	COMMENTS
0	Direct transmission selection to SMTP server 0: ON 1: OFF	Allows or does not allow the direct transmission to SMTP server.
1-7	Not used	Do not change these settings.

<b>Switch 06 - Not used</b> (do not change the settings)
--

<b>Switch 07 - Not used</b> (do not change the settings)
--

<b>Switch 08 - Not used</b> (do not change the settings)
--

<b>Switch 09 - Not used</b> (do not change the settings)
--

## Service RAM Addresses

### CAUTION

- Do not change the settings which are marked as "Not used" or "Read only."

#### **680001 to 680004(H) - ROM version (Read only)**

680001(H) - Revision number (BCD)

680002(H) - Year (BCD)

680003(H) - Month (BCD)

680004(H) - Day (BCD)

**680006 to 680015(H) - Machine's serial number (16 digits - ASCII)**

**680018(H) - Total program checksum (low)**

**680019(H) - Total program checksum (high)**

**680020 to 68003F(H) - System bit switches**

**680050 to 68005F(H) - Printer bit switches**

**680060 to 68007F(H) - Communication bit switches**

**680080 to 68008F(H) - G3 bit switches**

**680090 to 68009F(H) - G3-2 bit switches: Not used**

**6800A0 to 6800AF(H) - G3-3 bit switches: Not used**

**6800D0(H) - User parameter switch 00 (SWUER\_00) : Not used**

**6800D1(H) - User parameter switch 01 (SWUSR\_01) : Not used**

**6800D2(H) - User parameter switch 02 (SWUSR\_02)**

Bit 0: Forwarding mark printing on forwarded messages 0: Disabled, 1: Enabled

Bit 1: Center mark printing on received copies

(This switch is not printed on the user parameter list.)

0: Disabled, 1: Enabled

Bit 2: Reception time printing

(This switch is not printed on the user parameter list.)

0: Disabled, 1: Enabled

Bit 3: TSI print on received messages 0: Disabled, 1: Enabled

Bit 4: Checkered mark printing

(This switch is not printed on the user parameter list.)

0: Disabled, 1: Enabled

Bit 5: Not used

Bit 6: Not used

Bit 7: Not used

#### **6800D3(H) - User parameter switch 03 (SWUSR\_03: Automatic report printout)**

Bit 0: Transmission result report (memory transmissions) 0: Off, 1: On

Bit 1: Not used

Bit 2: Memory storage report 0: Off, 1: On

Bit 3: Polling reserve report (polling reception) 0: Off, 1: On

Bit 4: Polling result report (polling reception) 0: Off, 1: On

Bit 5: Transmission result report (immediate transmissions) 0: Off, 1: On

Bit 6: Not used

Bit 7: Journal 0: Off, 1: On

#### **6800D4(H) - User parameter switch 04 (SWUSR\_04: Automatic report printout)**

Bit 0: Not used

Bit 1: Automatic communication failure report and transfer result report output 0: Off, 1: On

Bits 2 to 3: Not used

Bit 4: Indicates the parties 0: Not indicated, 1: Indicated

Bit 5: Include sender's name on reports 0: Off, 1: On

Bit 6: Not used

Bit 7: Inclusion of a sample image on reports 0: Off, 1: On

#### **6800D5(H) - User parameter switch 05 (SWUSR\_05)**

Bit 0: Substitute reception when the base copier is in an SC condition

0: Enabled, 1: Disabled

Bits 1 and 2: Condition for substitute rx when the machine cannot print messages (Paper end, toner end, jam, and during night mode)

Bit 2: 0, Bit 1: 0 = The machine receives all the fax messages.

Bit 2: 0, Bit 1: 1 = The machine receives the fax messages with RTI or CSI.

Bit 2: 1, Bit 1: 0 = The machine receives the fax messages with the same ID code.

Bit 2: 1, Bit 1: 1 = The machine does not receive anything.

Bit 3: Not used

Bit 4: Not used

Bit 5: Just size printing 0: Off, 1: On

Bit 6: Not used

Bit 7: Add paper display when a cassette is empty 0: Off, 1: On

**6800D6(H) - User parameter switch 06 (SWUSR\_06):** Not used

**6800D7(H) - User parameter switch 07 (SWUSR\_07)**

Bit 0 Ringing 0: Off, 1: On

Bit 1: Automatic answering message 0: Off, 1: On

Bit 2: Parallel memory transmission 0: Off, 1: On

Bits 3 and 4: Not used

Bit 5: Remote control 0: Off, 1: On

Bits 6 and 7: Not used

**6800D8(H) - User parameter switch 08 (SWUSR\_08)**

Bits 0 and 1: Not used.

Bit 2: Authorized reception

0: Only faxes from senders whose RTIs/CSIs are specified for this feature are accepted.

1: Only faxes from senders whose RTIs/CSIs are not specified for this feature are accepted.

Bits 3 to 7: Not used.

**6800D9(H) - User parameter switch 09 (SWUSR\_09):** Not used

**6800DA(H) - User parameter switch 10 (SWUSR\_0A)**

Bits 0 to 2: Not used

Bit 3: Page reduction 0: Off, 1: On

Bits 4 and 5: Not used

Bit 6: Use both e-mail notification and printed reports to confirm the transmission results 0: Off, 1: On

Bit 7: Not used

**6800DB(H) - User parameter switch 11 (SWUSR\_0B)**

Bits 0 and 1: Not used

Bit 2: White original detection 0: Off, 1: On (alarm and alert message on the LCD)

Bit 3: Receive rejection for 1300 Hz transmission 0: Off (receive), 1: On (not receive)

Bit 5: Not used

Bit 6: Printout of messages received while acting as a forwarding station 0: Off, 1: On

Bit 7: Not used

**6800DC(H) - User parameter switch 12 (SWUSR\_0C):** Not used

**6800DD(H) - User parameter switch 13 (SWUSR\_0D):** Not used

**6800DE(H) - User parameter switch 14 (SWUSR\_0E)**

Bit 0: Message printout while the machine is in Night Printing mode 0: On, 1: Off

Bit 1: Maximum document length detection 0: Double letter, 1: Longer than double-letter (well log) – up to 1,200 mm

Bit 2: Not used

Bit 3: Fax mode settings, such as resolution, before a mode key (Copy/Fax/Printer/Scanner) is pressed  
0: Not cleared, 1: Cleared

Bits 4 to 6: Not used

Bit 7: Not used

#### **6800DF(H) - User parameter switch 15 (SWUSR\_OF)**

(This switch is not printed on the user parameter list.)

Bits 0, 1 and 2: Cassette for fax printout

Bit 2: 0, Bit 1: 0, Bit 0: 1 = 1st paper feed station

Bit 2: 0, Bit 1: 1, Bit 0: 0 = 2nd paper feed station

Bit 2: 0, Bit 1: 1, Bit 0: 1 = 3rd paper feed station

Bit 2: 1, Bit 1: 0, Bit 0: 0 = 4th paper feed station

Bit 2: 1, Bit 1: 0, Bit 0: 1 = LCT

Other settings Not used

Bits 3 and 4: Not used

Bit 5: Using the cassette specified by bits 0, 1 and 2 above only 0: On, 1: Off

Bits 6 and 7: Not used

#### **6800E0(H) – User parameter switch 16 (SWUSR\_10)**

(This switch is not printed on the user parameter list.)

Bits 0 and 1: Not used

Bit 2: Paper size selection priority for an A4 size fax message when A4/LT size paper is not available. 0: A3 has priority, 1: B4 has priority

Bits 3 to 7: Not used

#### **6800E1(H) – User parameter switch 17 (SWUSR\_11)**

Bit 0: Not used

Bit 1: Not used

Bit 2: Inclusion of the “Add” button when a sequence of Quick/Speed dials is selected for broadcasting  
0: Not needed, 1: Needed

Bits 3 to 6: Not used

Bit 7: Press “Start” key without an original when using the on hook dial or the external telephone,  
0: displays “Cannot detect original size”. 1: Receives fax messages.

#### **6800E2(H) - User parameter switch 18 (SWUSR\_12)**

Bit 0: TTI date 0: Off, 1: On

Bit 1: TTI sender 0: Off, 1: On

Bit 2: TTI file number 0: Off, 1: On

Bit 3: TTI page number 0: Off, 1: On

Bits 4 to 6: Not used

Bit 7: Japan only

**6800E3(H) - User parameter switch 19 (SWUSR\_13)**

Bit 0: Not used

Bit 1: Journal format

0: The Journal is separated into transmissions and receptions

1: The Journal is separated into G3-1, G3-2, and G3-3 communications

Bit 2: Not used

Bit 3: 90° image rotation during B5 portrait Tx (This switch is not printed on the user parameter list.) 0: Off, 1: On

Bit 4: Reduction of sample images on reports to 50% in the main scan and sub-scan directions. (This switch is not printed on the user parameter list.) 0: Technician adjustment (printer switch OE bits 3 and 4), 1: 50% reduction

Bit 5: Use of A5 size paper for reports (This switch is not printed on the user parameter list.) 0: Off, 1: On

Bits 6 and 7: Not used

**6800E4(H) - User parameter switch 20 (SWUSR\_14)**

Bit 0: Automatic printing of the LAN fax result report 0: Off, 1: On

Bit 1: Not used.

Bits 2 to 5: Store documents in memory which could not be printed from PC fax (LAN fax) driver

Bit 5	Bit 4	Bit 3	Bit 2	Setting
0	0	0	0	0 min.
0	0	0	1	1 min.
↓	↓	↓	↓	↓
1	1	1	0	14 min.
1	1	1	1	15 min.

Bits 6 and 7: Not used.

**6800E5(H) - User parameter switch 21 (SWUSR\_15)**



Bit 0: Print results of sending reception notice request message 0: Disabled (print only when error occurs), 1: Enabled

Bit 1: Respond to e-mail reception acknowledgment request 0: Disabled, 1: Enabled

Bit 2: Not used

Bit 3: File format for forwarded folders 0: TIFF, 1:PDF

Bit 4: Transmit Journal by E-mail 0: Disabled, 1: Enabled

Bit 5: Not used

Bit 6: Network error display 0: Displayed, 1: Not displayed

Bit 7: Transmit error mail notification 0: Enabled, 1: Disabled

#### **6800E6(H) - User parameter switch 22 (SWUSR\_16)**

(This switch is not printed on the user parameter list.)

Bit 0: Dial tone detection (PSTN 1) 0: Disabled, 1: Enabled

Bits 1 to 7: Not used

**6800E7(H) - User parameter switch 23 (SWUSR\_17):** Not used

**6800E8(H) - User parameter switch 24 (SWUSR\_18):** Not used

#### **6800E9(H) - User parameter switch 25 (SWUSR\_19)**

Bit 0: Not used

Bit 1: Reception mode switch timer 0: Off, 1: On (switching Fax or Fax/Tel)

Bit 2: Mode priority switch 0: Fax first, 1: Tel first

Bit 3: Dial in function (Japan Only)

Bit 4: RDS operation 0: Not acceptable, 1: Acceptable for the limit specified by system switch 03

#### **Note**

- This bit is only effective when RDS operation can be selected by the user (see system switch 02).

Bits 5 to 7: Not used

**6800EA(H) and 6800EB(H) - User parameter switches 26 and 27 (SWUSR\_1A and 1B):** Not used

**6800EC(H) - User parameter switch 28(SWUSR\_1C)**

Xxxxx

**6800ED(H) - User parameter switch 29(SWUSR\_1D)**

xxxxxx

**6800EE(H) and 6800EF(H) - User parameter switches 30 and 31 (SWUSR\_1E and 1F):** Not used

**6800F0(H) - User parameter switch 32 (SWUSR\_20)**

Bit 0: Quotation priority for a destination when there is no destination of the specified type

0: Paper output priority = Priority order: 1. IP-fax destination, 2. Fax Number, 3. E-mail address, 4. Folder

1: Electric putout order = Priority order: 1. E-mail address, 2. Folder, 3. IP-fax destination, 4. Fax number

Bits 1 to 7: Not used

**6800F1(H) - User parameter switch 33 (SWUSR\_21):** Not used

**6800F2(H) - User parameter switch 34 (SWUSR\_22)**

Bit 0: Gatekeeper server used with IP-Fax 0: Disabled, 1: Enabled

Bit 1: SIP server used with IP-Fax 0: Disabled, 1: Enabled

Bits 2 to 7: Not used

**680100 to 68010F(H) - G4 Parameter Switches –** Not used

**680110 to 68012F(H) - G4 Internal Switches –** Not used

**680130 to 68016F(H) - Service Switches**

**680170 to 68017F(H) - IFAX Switches**

**680180 to 68018F(H) - IP-FAX Switches**

**680190 to 6801AF(H) - Service station's fax number (SP3-101)**

**6801B0 to 6801B9(H) - Own fax PABX extension number**

**6801BA to 6801C3(H) - Own fax number (PSTN) –** Not used

**6801C4 to 6801D7(H) - Own fax number (ISDN G4) –** Not used

**6801D8 to 6801E3(H) - The first subscriber number (ISDN G3) –** Not used

**6801E4 to 6801EF(H) - The second subscriber number (ISDN G3) –** Not used

**6801F0 to 6801FB(H) - The first subscriber number (ISDN G4) –** Not used

**6801FC to 680207(H) - The second subscriber number (ISDN G4) –** Not used

**680208 to 68021B(H) - PSTN-1 RTI (Max. 20 characters - ASCII) -** See the following note.

**68021C to 68022F(H) - PSTN-2 RTI (Max. 20 characters - ASCII) -** Not used

**680230 to 680246(H) - PSTN-3 RTI (Max. 20 characters - ASCII) -** Not used

**680247 to 680286(H) - TTI 1 (Max. 64 characters - ASCII) -** See the following note.

**680287 to 6802C6(H) - TTI 2 (Max. 64 characters - ASCII) -** Not used

**6802C7 to 680306(H) - TTI 3 (Max. 64 characters - ASCII) -** Not used

**680307 to 68031A(H) - PSTN-1 CSI (Max. 20 characters - ASCII)**

**68031B to 68032E(H) - PSTN-2 CSI (Max.20 characters - ASCII) -** Not used

**68032F to 680342(H) - PSTN-3 CSI (Max.20 characters - ASCII) -** Not used

**680343(H) - Number of PSTN-1 CSI characters (Hex)**

**680344(H) - Number of PSTN-2 CSI characters (Hex) -** Not used

**680345(H) Number of PSTN-3 CSI characters (Hex) -** Not used

**Note**

- If the number of characters is less than the maximum (20 for RTI, 32 for TTI), add a stop code (00[H]) after the last character.

**680380 to 680387(H)** - Last power off time (Read only)

680380(H) - 01(H) - 24-hour clock, 00(H) - 12-hour clock (AM), 02(H) - 12-hour clock (PM)

680381(H) - Year (BCD)

680382(H) - Month (BCD)

680383(H) - Day (BCD)

680384(H) - Hour

680385(H) - Minute

680386(H) - Second

680387(H) - 00: Monday, 01: Tuesday, 02: Wednesday, ///, 06: Sunday

**680394(H)** - Optional equipment (Read only – Do not change the settings)

Bit 0: Page Memory 0: Not installed, 1: Installed

Bit 1: SAF Memory 0: Not installed, 1: Installed

Bits 2 to 7: Not used

**680395(H)** - Optional equipment (Read only – Do not change the settings)

Bits 0 to 3: Not used

Bit 4: G3-2 0: Not installed, 1: Installed

Bit 5: G3-3 0: Not installed, 1: Installed

Bit 6 and 7: Not used

**680406 to 68040A** – Option G3 board (G3-2) ROM information (Read only)

680406(H) - Suffix (BCD)

680407(H) - Version (BCD)

680408(H) - Year (BCD)

680409(H) - Month (BCD)

68040A(H) - Day (BCD)

**68040B to 68040F** – Option G3 board (G3-3) ROM information (Read only)

68040B(H) - Suffix (BCD)

68040C(H) - Version (BCD)

68040D(H) - Year (BCD)

68040E(H) - Month (BCD)

68040F(H) - Day (BCD)

680410(H)	- G3-1 Modem ROM version (Read only)
680412(H)	- G3-2 Modem ROM version (Read only)
680414(H)	- G3-3 Modem ROM version (Read only)
680420(H)	- Number of multiple sets print (Read only)
680476(H)	- Time for economy transmission (hour in 24h clock format - BCD)
680477(H)	- Time for economy transmission (minute - BCD)
680492(H)	- Transmission monitor volume 00 - 07(H)
680493(H)	- Reception monitor volume 00 - 07(H)
680494(H)	- On-hook monitor volume 00 - 07(H)
680495(H)	- Dialing monitor volume 00 - 07(H)
680496(H)	- Buzzer volume 00 - 07(H)
680497(H)	- Beeper volume 00 - 07(H)
6804A8(H)	- Machine code (Check ram 4)
68918E(H)	- Gatekeeper server address - Main (Max. 128 characters - ASCII)
68920E(H)	- Gatekeeper server address - Sub (Max. 128 characters - ASCII)
68928E(H)	- Arias Number (Max. 128 characters - ASCII)
68930E(H)	- SIP user name (Max. 128 characters - ASCII)
68938E(H)	- <b>SIP digest authentication password</b> (Max. 128 characters - ASCII)
68940E(H)	- Gateway address information (Max. 7100 characters - ASCII)
68AFCA(H)	- Stand-by port number for H.232 connection
68AFCCH)	- Stand-by port number for SIP connection
68AFCE(H)	- RAS port number
68AFD0(H)	- Gatekeeper port number
68AFD2(H)	- Port number of data waiting for T.38
68AFD4(H)	- Port number of SIP server
68AFD6(H)	- Priority for SIP and H.323 0: H.323, 1: SIP
68AFD7(H)	- SIP function 0: Disabled, 1: Enabled
68AFD8(H)	- H.323 function 0: Disabled, 1: Enabled
68AFD9(H)	- <b>SIP digest authentication function</b> 0: Disabled, 1: Enabled
68AFDA(H)	- <b>IP-Fax backup data</b> 00 - 600 (H) - Not used
69ED6A(H) to 69ED92(H)	- SIP server address (Read only)
69ED6A(H)	- Proxy server - Main (Max. 128 characters - ASCII)
69ED72(H)	- Proxy server - Sub (Max. 128 characters - ASCII)

69ED7A(H) - Redirect server - Main (Max. 128 characters - ASCII)

69ED82(H) - Redirect server - Sub (Max. 128 characters - ASCII)

69ED8A(H) - Registrar server - Main (Max. 128 characters - ASCII)

69ED92(H) - Registrar server - Sub (Max. 128 characters - ASCII)

**6BEBFE(H) - 6BEC1E (H) - Dial tone detection parameter** (Max. 11 x 3 lines)

This initializes following order. [0x04, 0x40, 0x03, 0x60, 0x64, 0xf4, 0x01,0x64, 0x04, 0xc8, 0x00]

**6BEBFE(H)** – Dial tone detection frequency – Upper limit (High)

Defaults: NA: 06, EU: 06, ASIA: 06

**6BEBFF(H)** – Dial tone detection frequency – Upper Limit (Low)

Defaults: NA: 50, EU: 50, ASIA: 50

**6BEC00(H)** – Dial tone detection frequency – Lower Limit (High)

Defaults: NA: 03, EU: 02, ASIA: 02

**6BEC01(H)** – Dial tone detection frequency – Lower Limit (Low)

Defaults: NA: 60, EU: 90, ASIA: 90

**6BEC02(H)** –Dial tone detection waiting time (20 ms)

Defaults: NA: 64, EU 64, ASIA: 64

**6BEC03 to 6BEC04** – Dial tone detection monitoring time (20 ms)

Defaults

Area	6BEC03	6BEC04
NA	F4	01
EU	F4	01
ASIA	F4	01

**6BEC05(H)** – Dial tone detect judge time (20 ms)

Defaults: NA: 64, EU: 1B, ASIA: 32

**6BEC06(H)** – Dial tone disconnect permission time (20 ms)

Defaults: NA: 11, EU: 0F, ASIA: 11



# 5. Specifications

## General Specifications

### FCU

Type:	Desktop type transceiver
Circuit:	PSTN (max. 3ch.) PABX
Connection:	Direct couple
Original Size:	<p>Book (Face down) Maximum Length: 432 mm [17 ins] Maximum Width: 297 mm [11.7 ins]</p> <p>ARDF (Face up) (Single-sided document) Length: 128 - 1200 mm [5.0 - 47.2 ins] Width: 105 - 297 mm [4.1 - 11.7 inch]</p> <p>(Double-sided document) Length: 128 - 432 mm [5.0 - 17 inch] Width: 105 - 297 mm [4.1 - 11.7 inch]</p>
Scanning Method:	Flat bed, with CCD
Resolution:	<p>G3</p> <p>8 x 3.85 lines/mm (Standard)</p> <p>8 x 7.7 lines/mm (Detail)</p> <p>8 x 15.4 line/mm (Fine) See Note 1</p> <p>16 x 15.4 line/mm (Super Fine) See Note 1</p> <p>200 x 100 dpi (Standard)</p> <p>200 x 200 dpi (Detail)</p> <p>400 x 400 dpi (Super Fine) See Note 1</p> <p><b>Note</b></p> <ul style="list-style-type: none"> <li>Optional Expansion Memory required</li> </ul>

Transmission Time:	G3: 3 s at 28800 bps; Measured with G3 ECM using memory for an ITU-T #1 test document (Slerexe letter) at standard resolution
Data Compression:	MH, MR, MMR, JBIG
Protocol:	Group 3 with ECM
Modulation:	V.34, V.33, V.17 (TCM), V.29 (QAM), V.27ter (PHM), V.8, V.21 (FM)
Data Rate:	G3: 33600/31200/28800/26400/24000/21600/ 19200/16800/14400/12000/9600/7200/4800/2400 bps Automatic fallback
I/O Rate:	With ECM: 0 ms/line Without ECM: 2.5, 5, 10, 20, or 40 ms/line
Memory Capacity:	ECM: 128 KB SAF Standard: 4 MB With optional Expansion Memory: 28 MB (4 MB+ 24 MB) Page Memory Standard: 4 MB (Print: 2 MB + Scanner: 2 MB) With optional Expansion Memory: 12 MB (4 MB + 8 MB) (Print 8 MB + Scanner: 4 MB)

## Capabilities of Programmable Items

The following table shows the capabilities of each programmable items.

Item	Standard
Quick Dial	2000
Groups	100
Destination per Group	500
Destinations dialed from the ten-key pad overall	500
Programs	100



Auto Document	6
Communication records for Journal stored in the memory	200
Specific Senders	30

The following table shows how the capabilities of the document memory will change after the Expansion Memory are installed.

	Without the Expansion Memory	With the Expansion Memory
Memory Transmission file	400	400
Maximum number of page for memory transmission	1000	1000
Memory capacity for memory transmission (Note 1)	320	2240

**Note**

- Measured using an ITU-T #1 test document (Slerexe letter) at the standard resolution, the auto image density mode and the Text mode.

## IFAX Specifications

<b>Connectivity:</b>	Local area network Ethernet 100base-Tx/10base-T IEEE802.11a/g, g (wireless LAN), 1000 Base-T
<b>Resolution:</b>	Main scan: 400 dpi, 200 dpi Sub scan: 400 dpi, 200 dpi, 100 dpi <b>Note</b> <ul style="list-style-type: none"> <li>To use 400 dpi, IFAX SW01 Bit 4 must be set to "1".</li> </ul>
<b>Transmission Time:</b>	1 s (through a LAN to the server) Condition: ITU-T #1 test document (Selerexe Letter) MTF correction: OFF TTI: None Resolution: 200 x 100 dpi Communication speed: 10 Mbps Correspondent device: E-mail server Line conditions: No terminal access
<b>Document Size:</b>	Maximum message width is A4/LT. <b>Note</b> <ul style="list-style-type: none"> <li>To use B4 and A3 width, IFAX SW00 Bit 1 (B4) and/or Bit 2 (A3) must be set to "1".</li> </ul>
<b>E-mail File Format:</b>	Single/multi-part MIME conversion Image: TIFF-F (MH, MR, MMR)
<b>Protocol:</b>	<b>Transmission:</b> SMTP, TCP/IP <b>Reception:</b> POP3, SMTP, IMAP4, TCP/IP
<b>Data Rate:</b>	100 Mbps(100base-Tx) 10 Mbps (10base-T)

<b>Authentication Method:</b>	SMTP-AUTH POP before SMTP A-POP
<b>Remark:</b>	The machine must be set up as an e-mail client before installation. Any client PCs connected to the machine through a LAN must also be e-mail clients, or some features will not work (e.g. Autorouting).

## IP-FAX Specifications

Network:	Local Area Network Ethernet/10base-T, 100base-TX IEEE802.11a/g, g (wireless LAN), 1000 Base-T
Scan line density:	8 x 3.85 lines/mm, 200x100dpi (standard character), 8 x 7.7lines/mm, 200x200dpi (detail character), 8 x 15.4lines/mm (fine character: optional expansion memory required), 16 x 15.4lines/mm, 400x400dpi (super fine character: optional expansion memory required)
Original size:	Maximum A3 or 11"x 17" (DLT)
Maximum scanning size:	Standard: A3, 297mm x 432mm Irregular: 297mm x 1200mm
Transmission protocol:	Recommended: T.38 Annex protocol, TCP, UDP/IP communication
Compatible machines:	IP-Fax compatible machines
IP-Fax transmission function:	Specify IP address and send fax to an IP-Fax compatible fax through a network. Also capable of sending fax from a G3 fax connected to the public telephone lines via a VoIP gateway.
IP-Fax reception function:	Receive a fax sent from an IP-Fax compatible fax through a network. Also capable of receiving fax from a G3 fax connected the public telephone lines via a VoIP gateway.

# Fax Unit Configuration

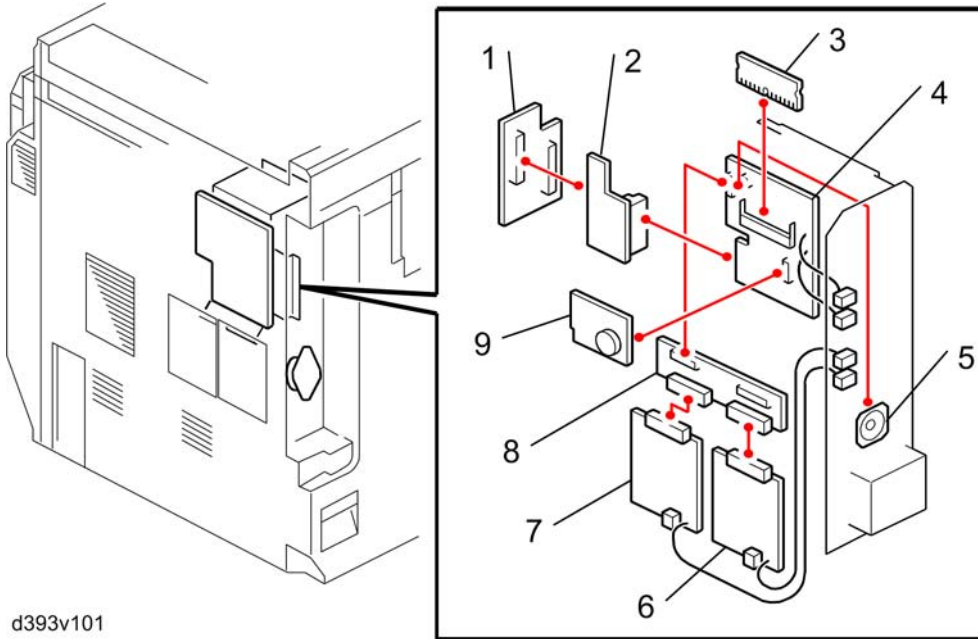

d393v101

5

Component	Code	No.	Remarks
MBU		9	Included with the fax unit
FCU		4	
FCU I/F	D545	2	
GWFCU I/F		1	
Speaker		5	
Expansion Memory	G578	3	Optional
CCU I/F Board	D393	8	Optional
SG3 Board		6	
SG3 Board (2nd)	D393	7	Optional
Handset Type 1018	B433	-	NA only. Also used with AT/AP-C2

