

Booklet Finisher SR3000
Machine Code: B793

SERVICE MANUAL

Apr. 21st, 2006
Subject to change

Read This First

Safety and Symbols

Replacement Procedure Safety

CAUTION

- Turn off the main power switch and unplug the machine before beginning any of the replacement procedures in this manual.

When taking apart the bridge unit, first take the unit out of the copier.

Symbols Used in this Manual

This manual uses the following symbols.

: See or Refer to

: Screws

: Connector

: Clip ring

: E-ring

Table of Contents

Read This First	i
Safety and Symbols	i
Replacement Procedure Safety	i
Symbols Used in this Manual	i
Table of Contents	ii
1. Replacement and Adjustment	1
Covers	1
Front/Inner/Rear Covers	1
Upper Covers	2
Main Body	4
Positioning Roller	4
Shift Tray Position Sensor, Upper Limit Switch	4
Proof Tray Exit / Full Sensor	6
Finisher Entrance Sensor	7
Shift Tray Exit Sensor	7
Staple Tray Paper Sensor	8
Shift Tray Motor	9
Entrance Motor	10
Upper Transport Motor	10
Lower Transport Motor	11
Shift Motor	12
Folder	13
Staple Folder Unit	13
Folder Unit	14
Folder Unit Exit Sensor	15
Folder Unit Entrance Sensor	16
Stapler Unit	16
Others	27
Main Board	27
DIP Switches	28
2. Detailed Section Descriptions	29
Component Layout	29
Mechanical Component Layout	29
Drive Layout	30

Electrical Component Layout.....	31
Electrical Component Descriptions.....	35
Junction Gates	40
Proof Tray.....	41
Shift Tray	42
Up/Down Motion	42
Side-to-side Motion.....	43
Booklet Tray	44
Jogger Unit.....	47
Exit Guide Plate, Paper Feed Out.....	48
Stapler Unit Movement.....	49
Stacking for Booklet Stapling.....	50
Overview.....	50
B4 or Shorter Than B4.....	50
Longer Than B4.....	51
Moving the Stack to the Folding Position	53
Folder	54
Overview.....	54
Fold Plate	54
Fold Rollers	55
Punch Unit.....	56
Overview of Operation.....	56
Paper Position Detection	58
Punch Unit Movement	59
Punch Selection and Firing.....	59
Punch Hopper Mechanism	61

1. Replacement and Adjustment

Covers

Front/Inner/Rear Covers

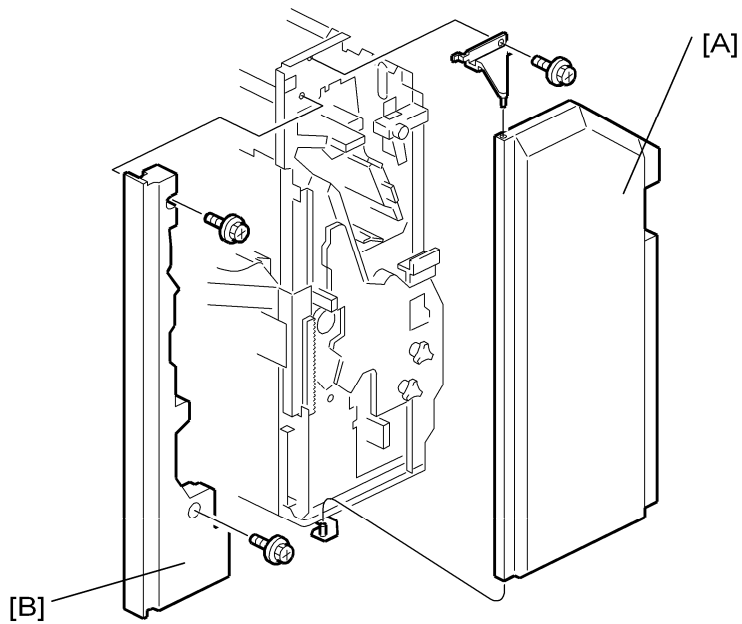

1. Remove the front cover [A] (⚙️ x 1).
2. Remove the inner cover [B] (⚙️ x 2).

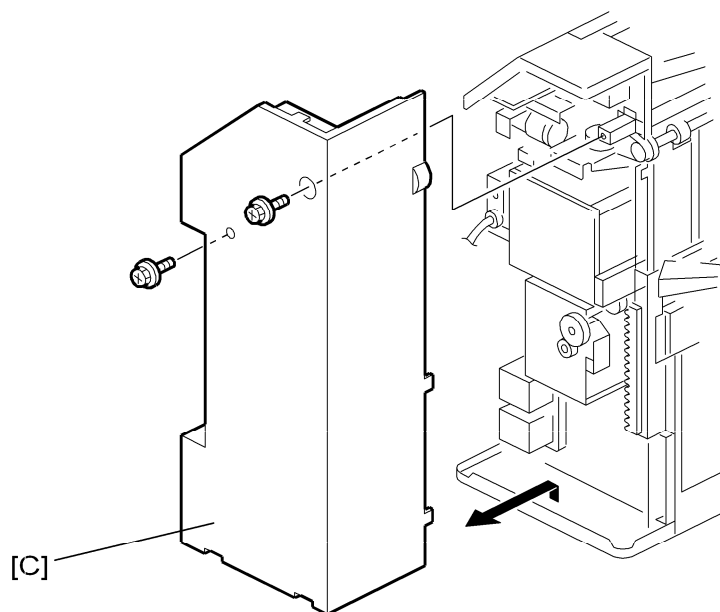

3. Remove the rear cover [C] (⚙️ x 2).

Upper Covers

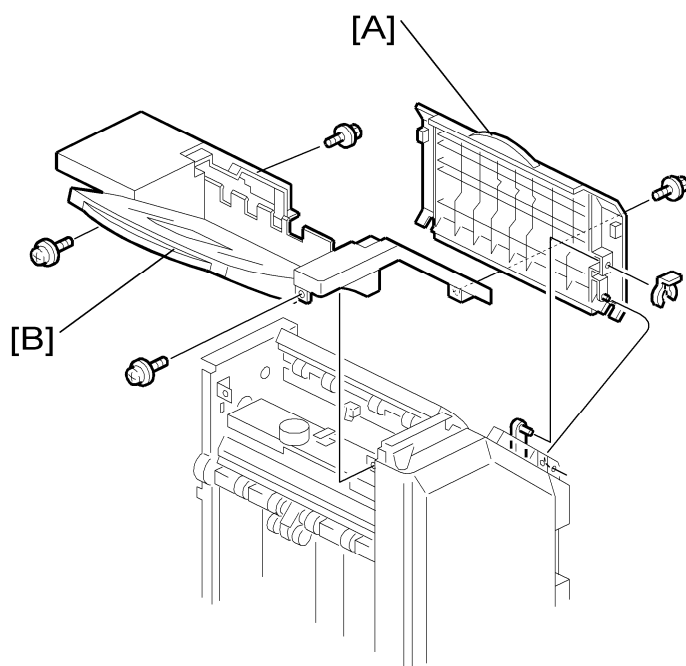

1. Remove the upper cover [A] (⚙️ x 1).
2. Remove the proof tray [B] (⚙️ x 4).

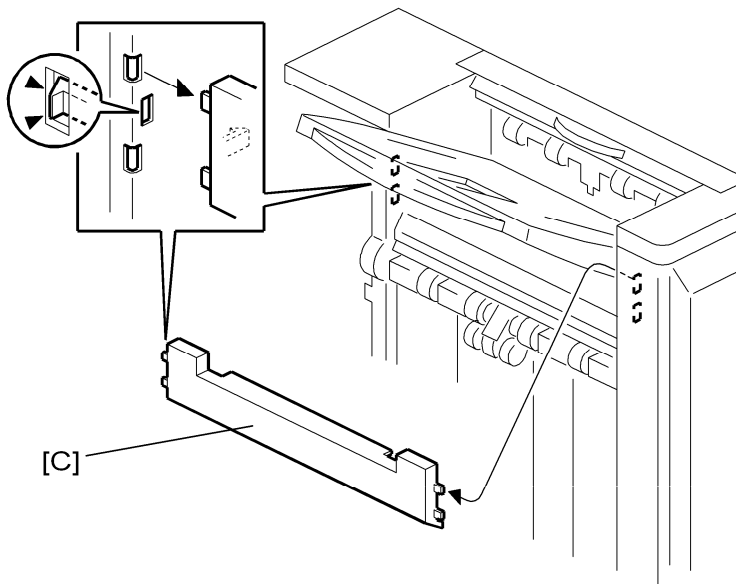

3. Remove the upper left cover [C].

Main Body

Positioning Roller

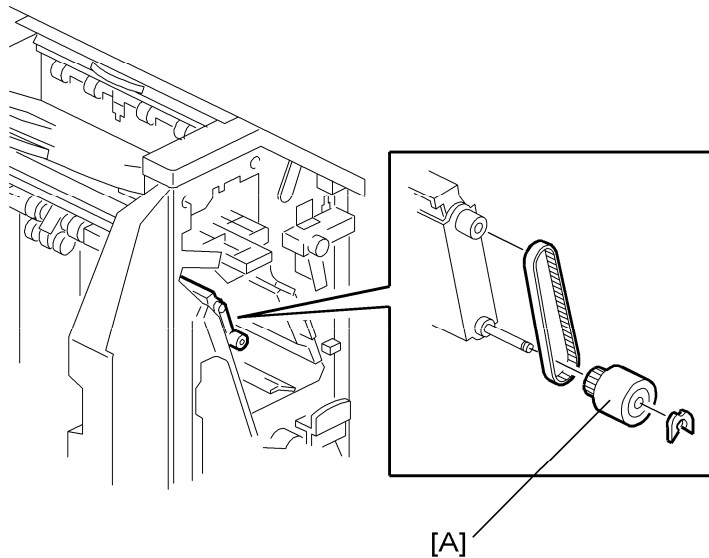

1. **Open the front cover.**
2. **Remove the positioning roller [A] (🔧 x 1).**

Shift Tray Position Sensor, Upper Limit Switch

1. **Remove the following items.**
 - Front Cover
 - Inner Cover
 - Rear Cover
 - Proof Tray
 - Upper Left Cover

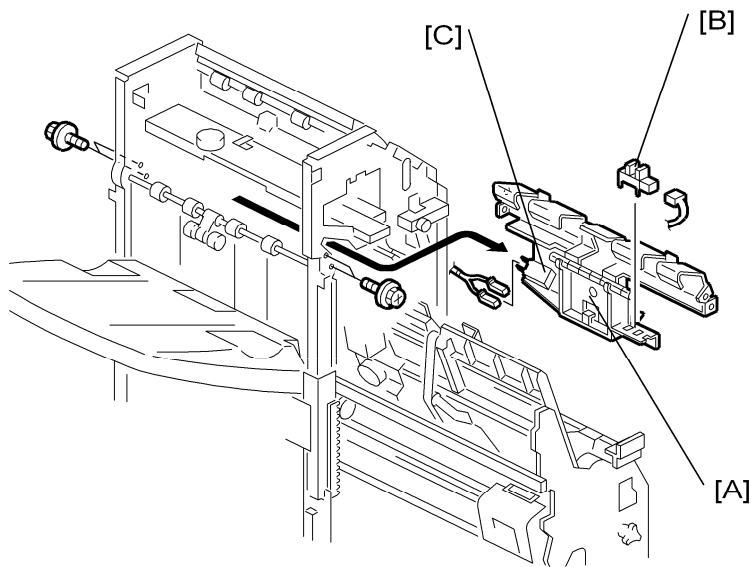

2. Remove the lower guide unit [A] (🔩 x 4, 📏 x 2).
3. Remove the shift tray position sensor [B] (📏 x 1).
4. Remove the upper limit switch [C] (📏 x 2). (Pull it out from the assembly.)

Proof Tray Exit / Full Sensor

1. Remove the front cover, rear cover and proof tray.
2. Open the upper cover.

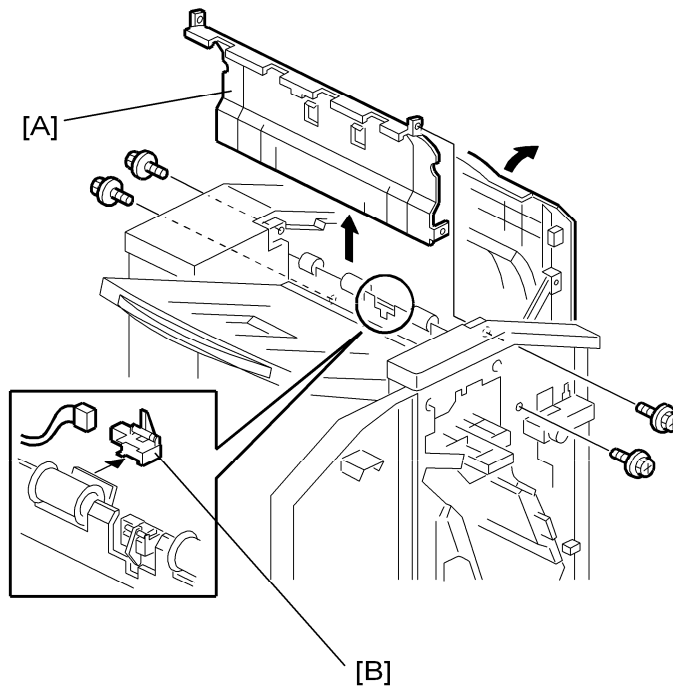

3. Remove the vertical transport guide [A] (🔧 x 4).
4. Remove the exit sensor [B] (🔧 x 1).

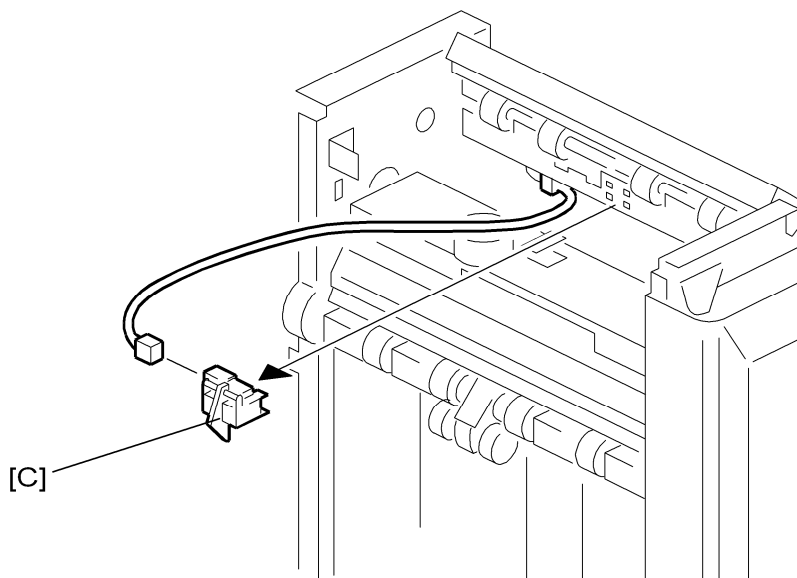

5. Remove the tray full sensor [C] (🔧 x 1).

Finisher Entrance Sensor

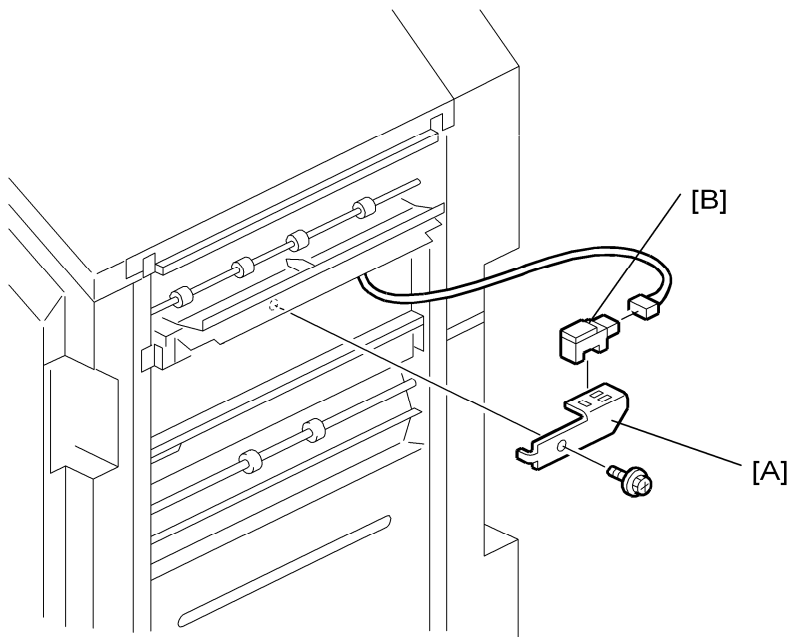

1. Remove the finisher entrance sensor with bracket [A] (🔧 x 1).
2. Remove the finisher entrance sensor [B] (🔧 x 1).

Shift Tray Exit Sensor

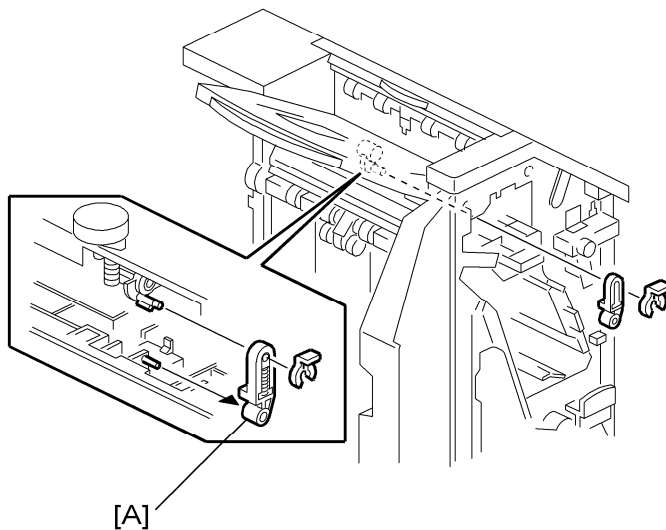

1. Remove the front cover and upper left cover.
2. Remove the link [A] (🔧 x 1).

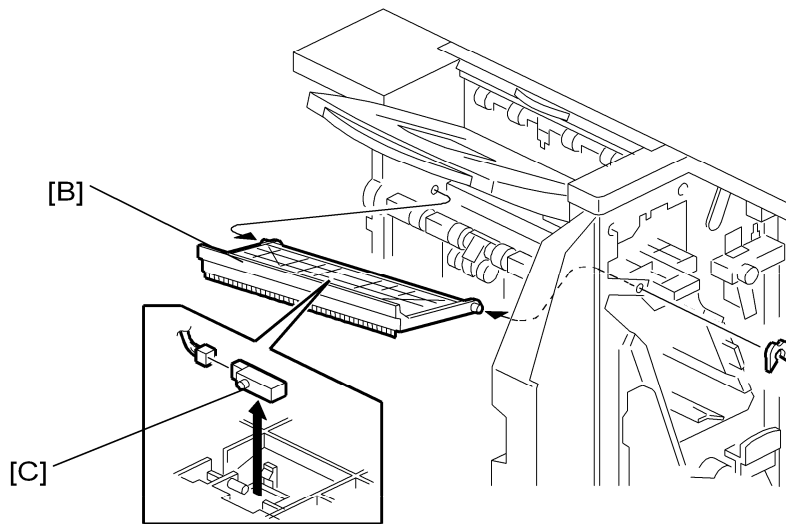

3. Remove the exit guide unit [B].
4. Remove the sensor [C] (☞ x 1).

Staple Tray Paper Sensor

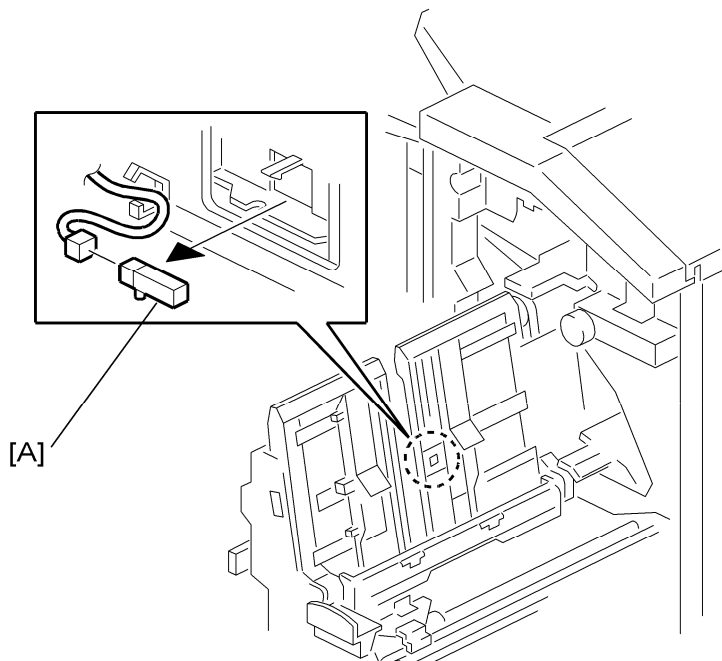

1. Open the front cover.
2. Pull out the staple/fold unit.
3. Remove the staple tray paper sensor [A] (☞ x 1).

Shift Tray Motor

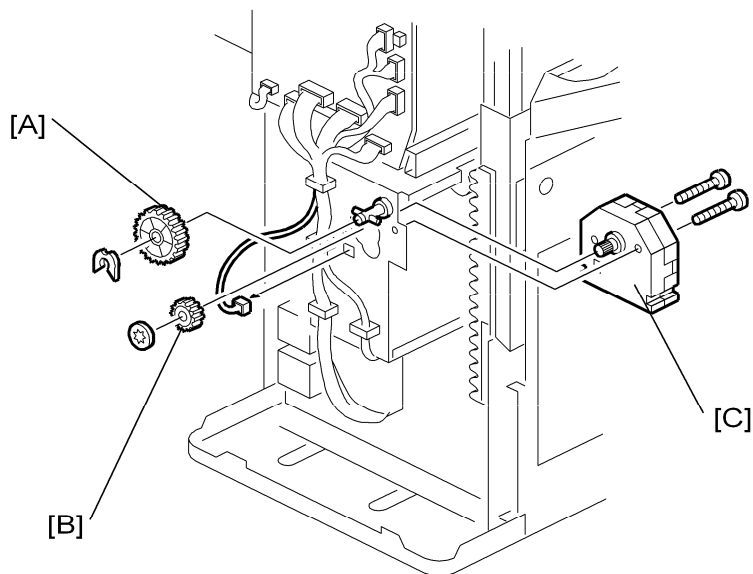

1. Remove the rear cover.
2. Open the front cover, and then pull out the staple/fold unit.
3. Remove the two gears [A], [B].
4. Remove the shift tray motor [C] (⚙️ x 2, 📦 x 1)

Entrance Motor

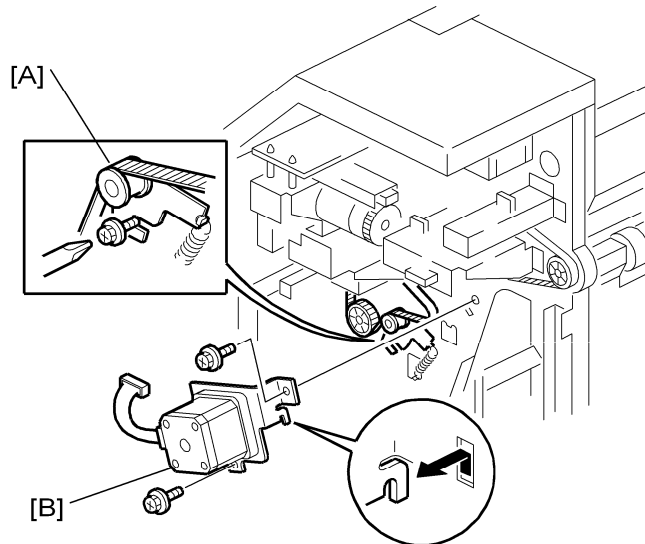

1. Remove the rear cover.
2. Release the belt tension [A].
3. Remove the entrance motor [B] (⚙ x 2, 🍬 x 1).

Upper Transport Motor

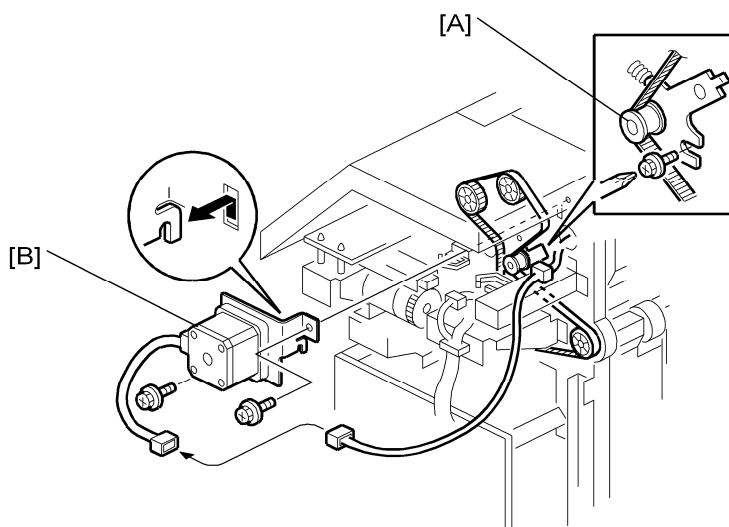

1. Remove the rear cover.
2. Release the belt tension [A].
3. Remove the upper transport motor [B] (⚙ x 2, 🍬 x 1).

Lower Transport Motor

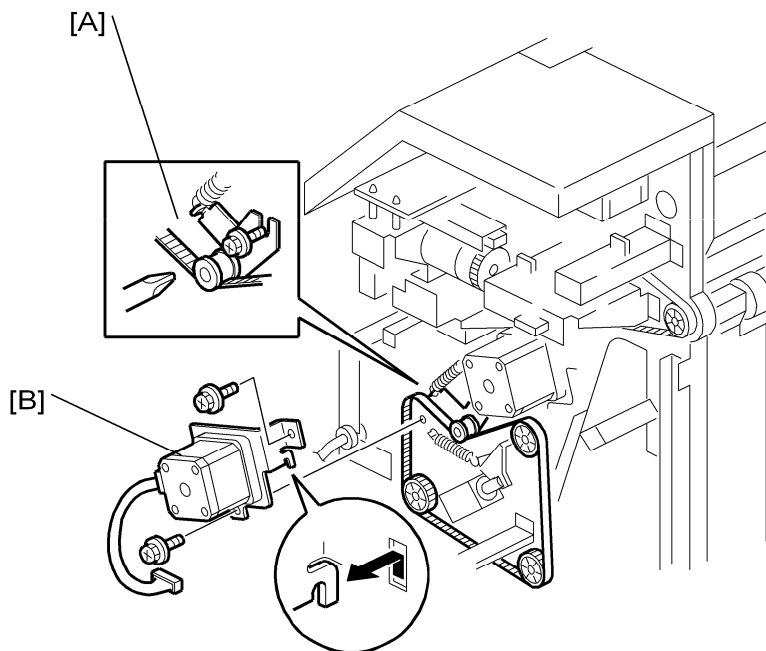

1. Remove the rear cover.
2. Release the belt tension [A].
3. Remove the lower transport motor [B] (🔩 x 2, 🔑 x 1).

Shift Motor

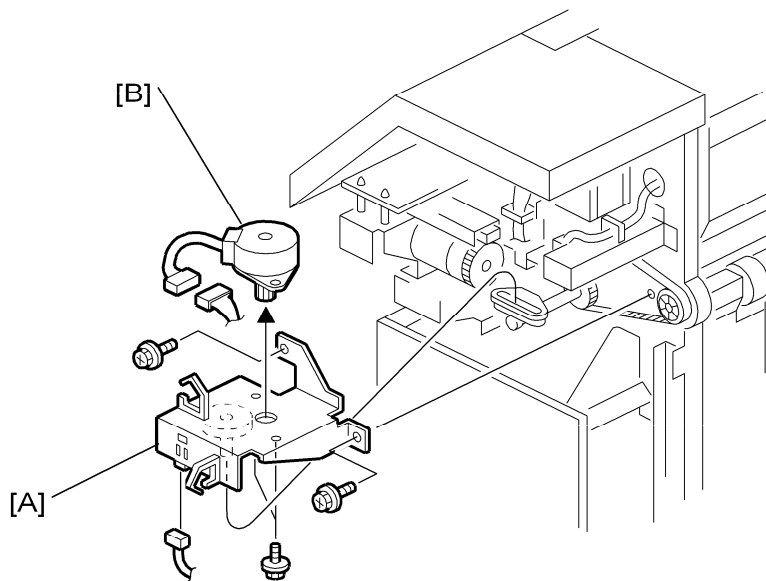

1. Remove the rear cover.
2. Remove the shift motor with bracket [A] (🔩 x 1, 🔧 x 4)
3. Remove the shift motor [B] (🔩 x 1).

Folder

Staple Folder Unit

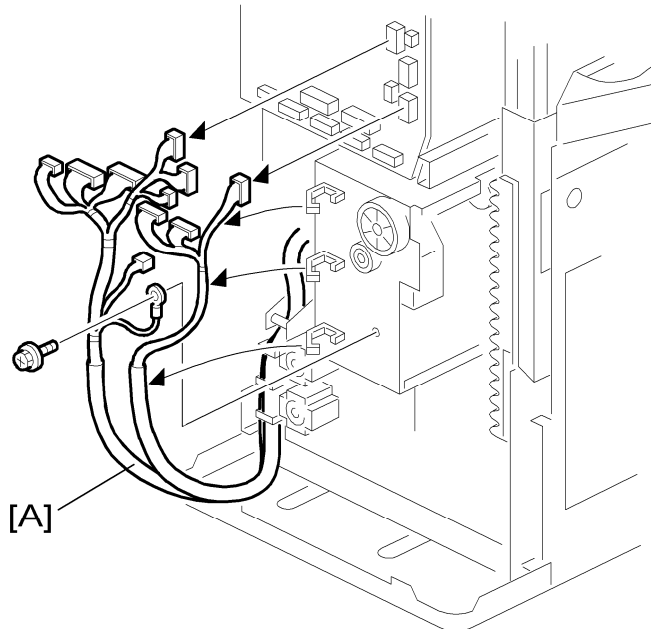

1. Remove the rear cover.
2. Disconnect all connectors and release the harness [A] for the staple folder unit (⚙️ x 1, 🛠️ x 3).
3. Open the front cover.

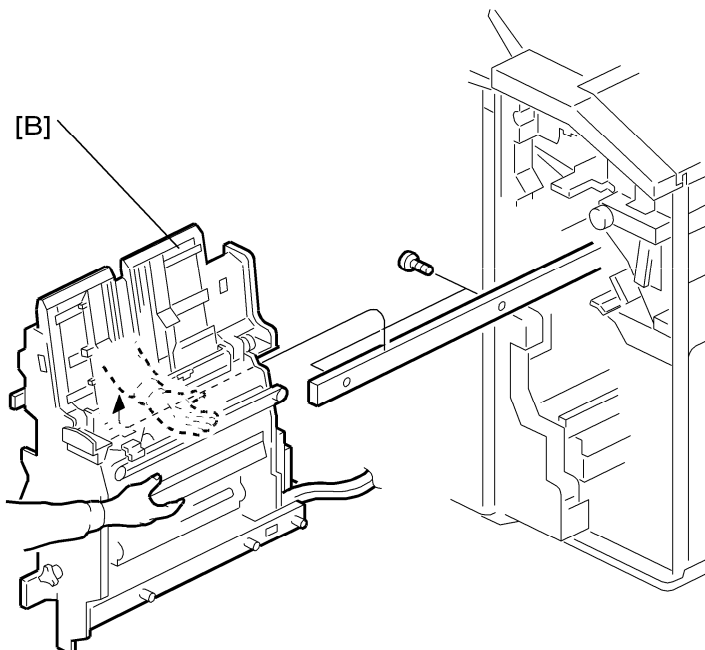

4. Pull out and remove the staple folder unit [B] (⚙️ x 2).

Folder Unit

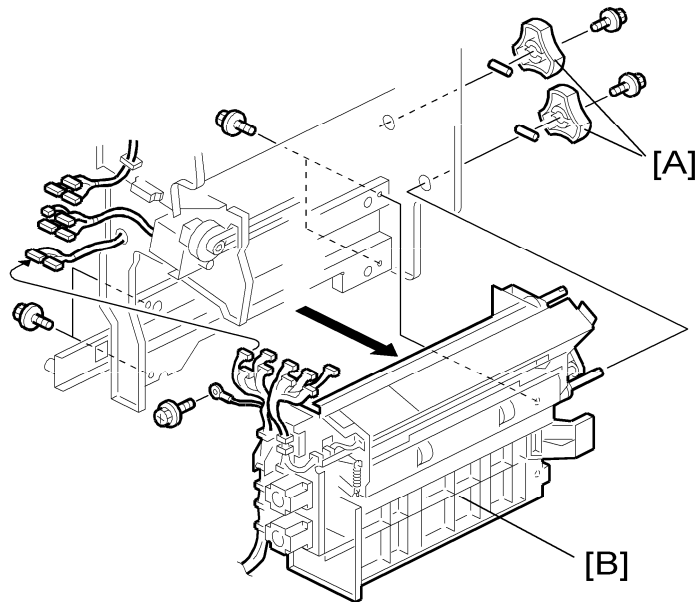
1. Remove the staple folder unit.

2. Remove the knobs [A] (⚙ x 1 each).
3. Disconnect the connectors.
4. Remove the folder unit [B] (⚙ x 4).

Folder Unit Exit Sensor

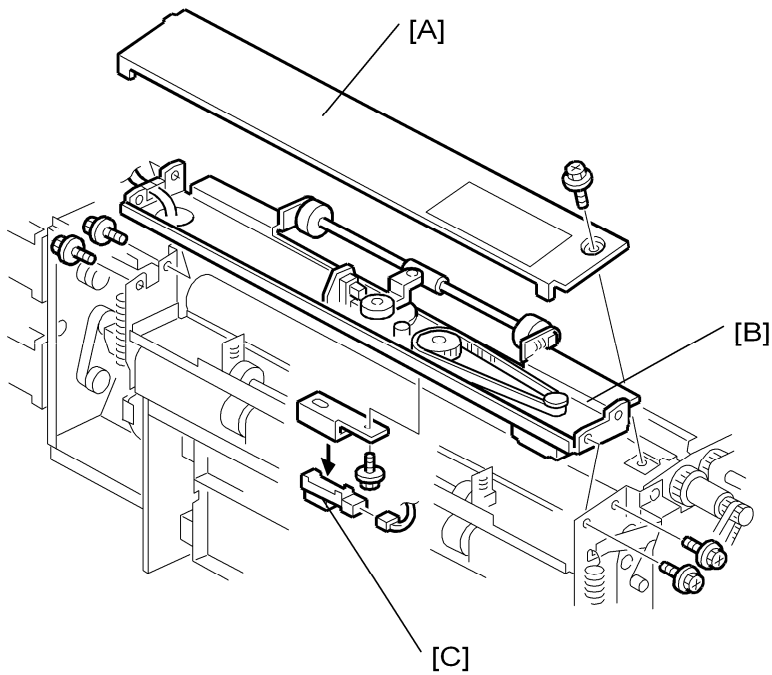

1. Remove the folder unit.
2. Remove the folder unit upper cover [A] (🔧 x 1).
3. Remove the lower clamp roller unit [B] (🔧 x 4).
4. Remove the folder unit exit sensor [C] (🔧 x 1, 📏 x 1).

Folder Unit Entrance Sensor

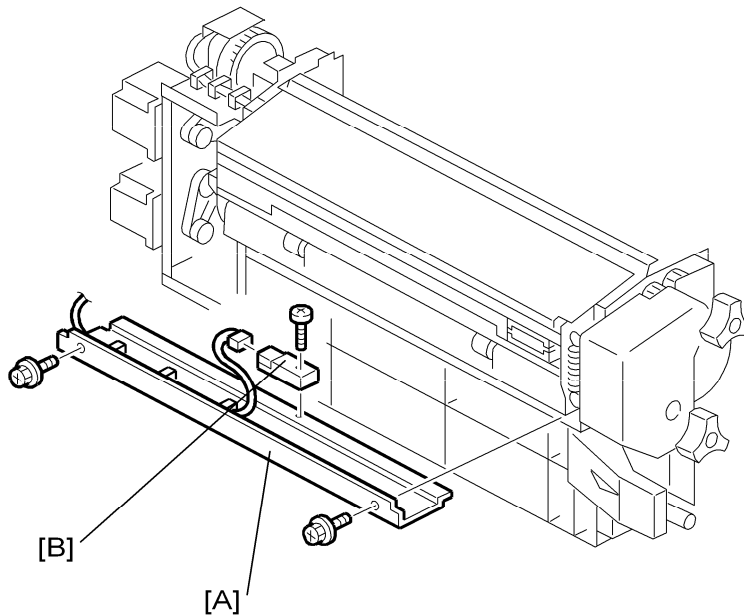

1. Open the front cover.
2. Pull out the staple folder unit.
3. Remove the exit cover [A] (🔩 x 2).
4. Remove the entrance sensor [B] (🔩 x 1, 📏 x 1).

Stapler Unit

1. Remove the rear cover.

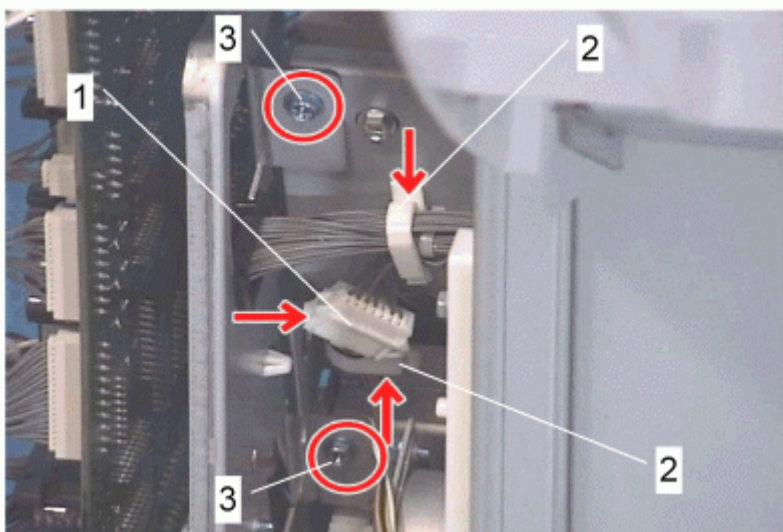

2. Disconnect the connector [1] and release the harness (📏 x 2 [2]).
3. Remove two screws [3].

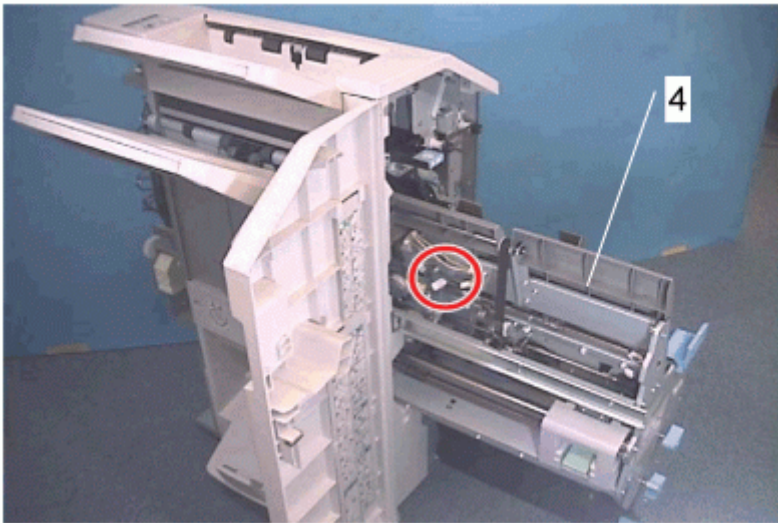

4. Open the front cover and pull out the staple folder unit [4].

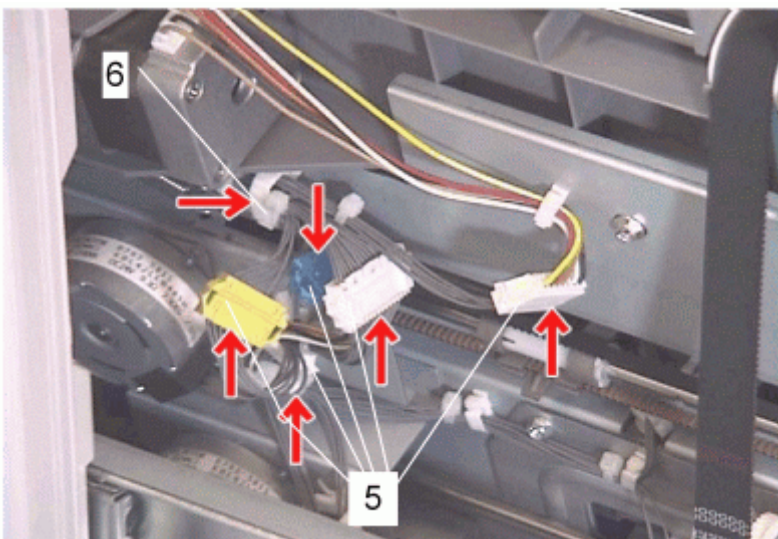

5. Disconnect the connectors and release the harness. (4 connectors [5], 1 clamp [6])

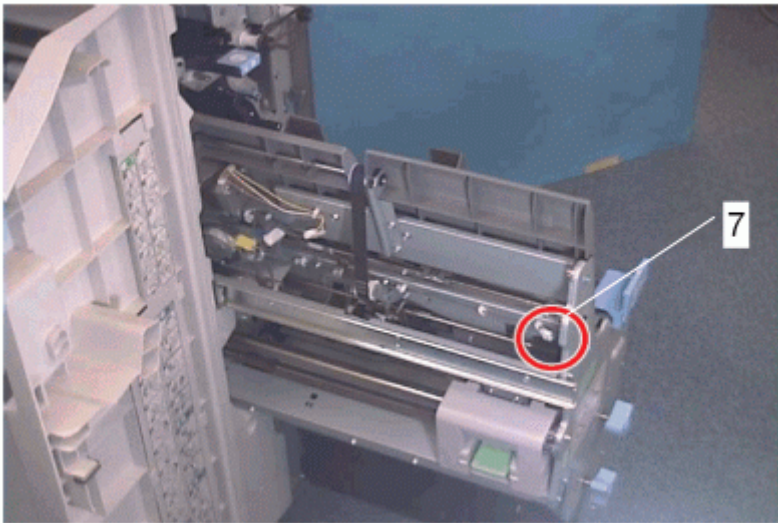

6. Remove a connector [7].

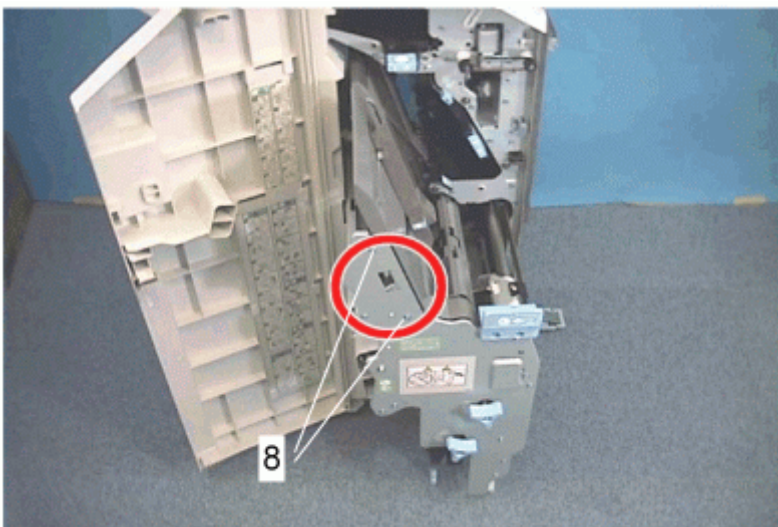

7. Remove 2 screws [8].

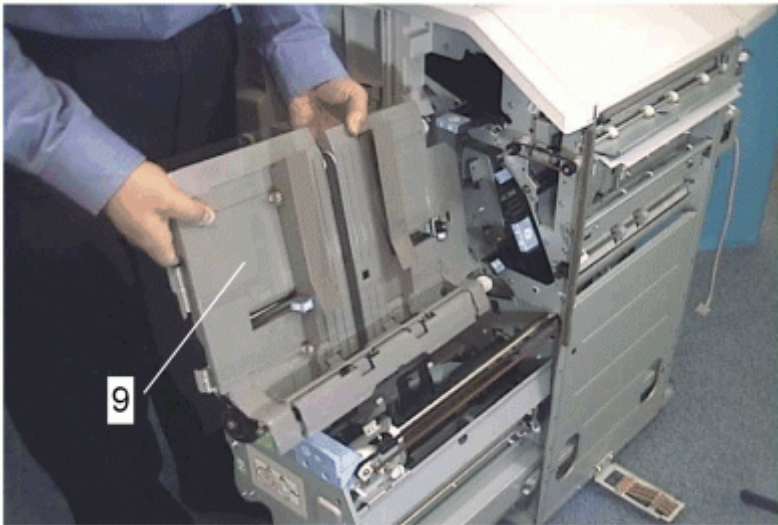

8. Remove the staple tray [9].

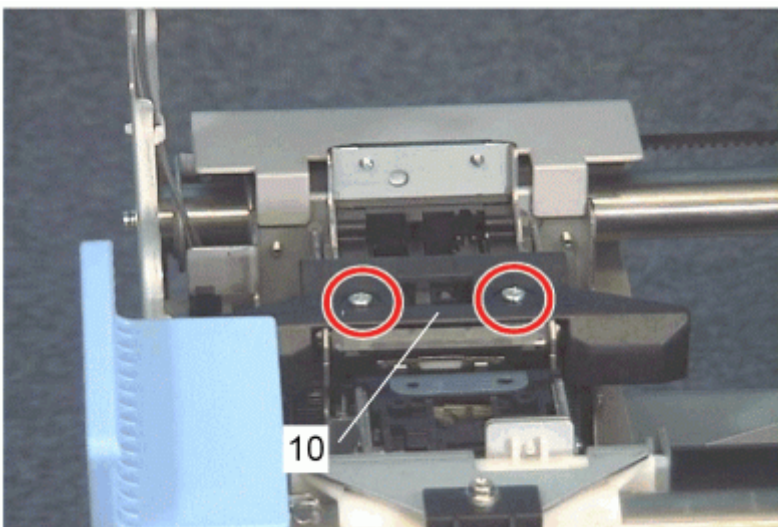

9. Remove the guide [10]. (2 screws)



10. Move the stapler unit until its screw come to the hole [11] on the stay.

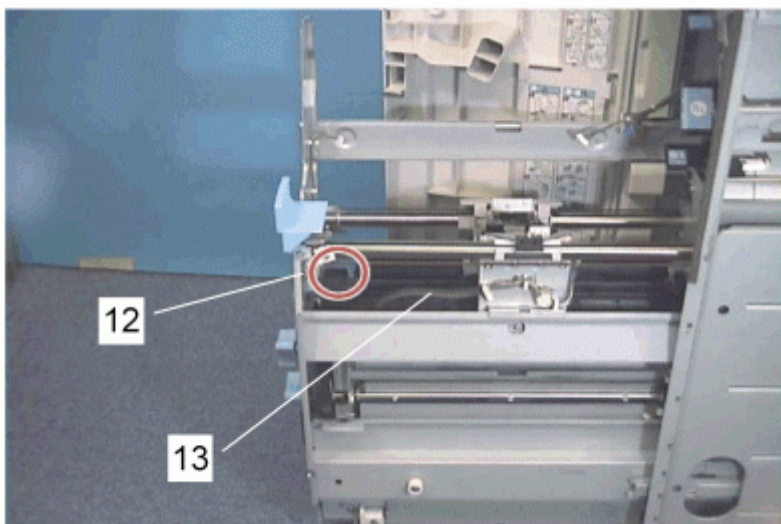

11. Remove the screw [12] that holds the front of the guide plate [13].

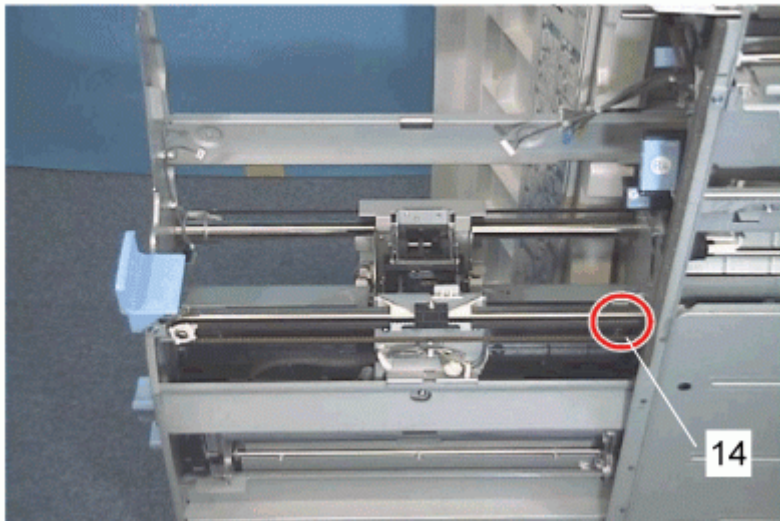

12. Remove the screw [14] that holds the rear of the guide plate.



↓ Note

- Remove the rear side screw through the hole in the stay.

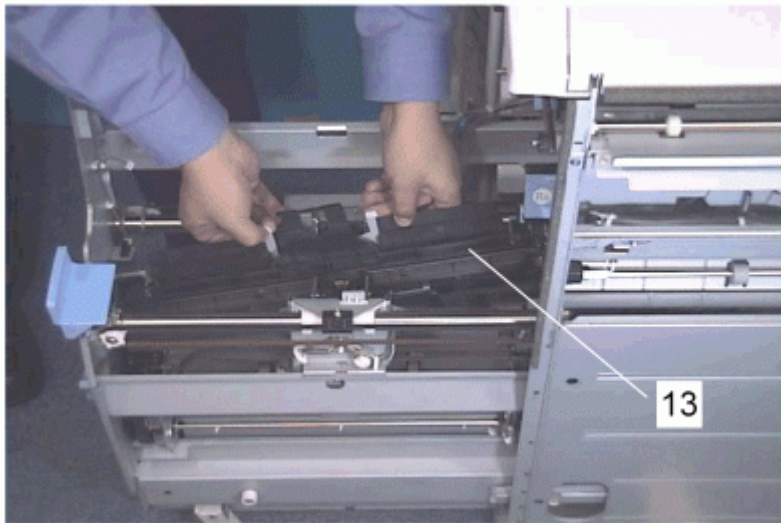

13. Remove the guide plate [13].

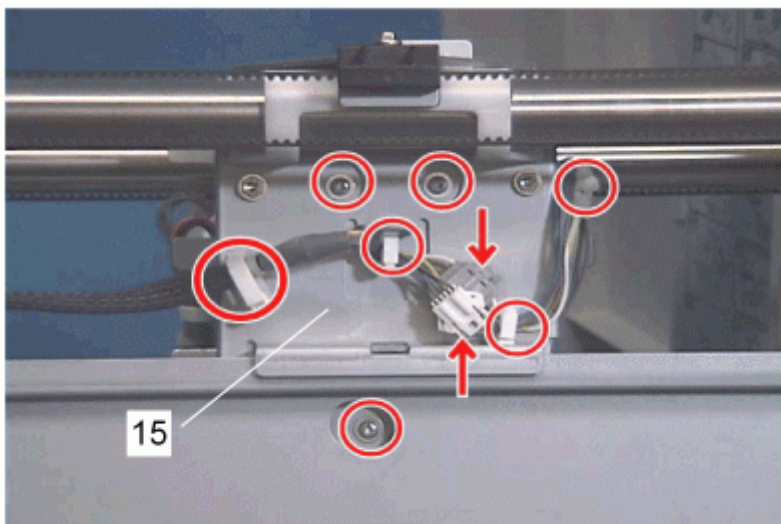

14. Remove the staple folding unit [15] (3 screws, 2 connectors).

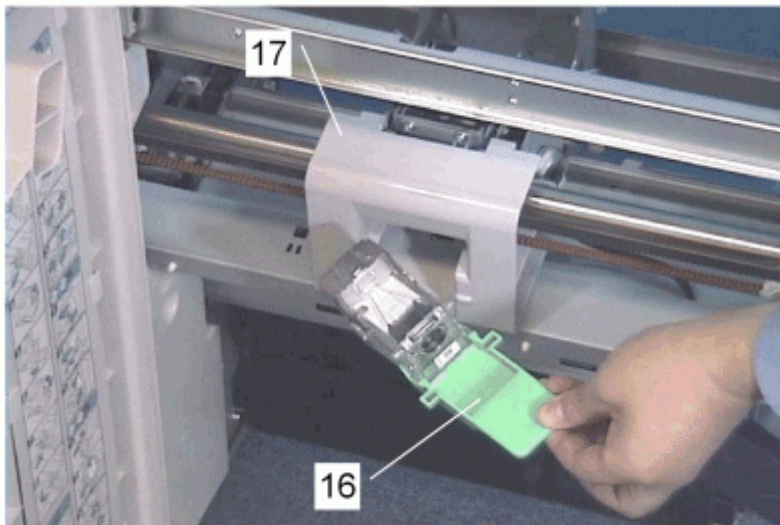

- 15. Remove the staple cartridge [16].
- 16. Remove the stapler unit cover [17].

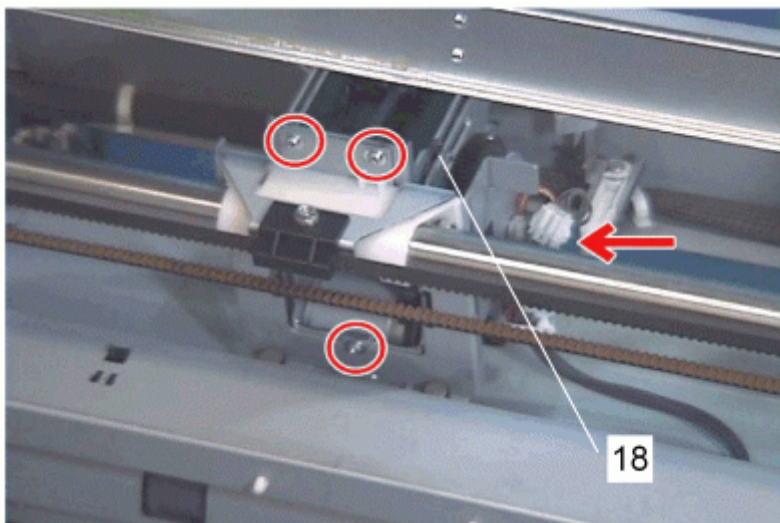

- 17. Remove the stapler drive unit [18].

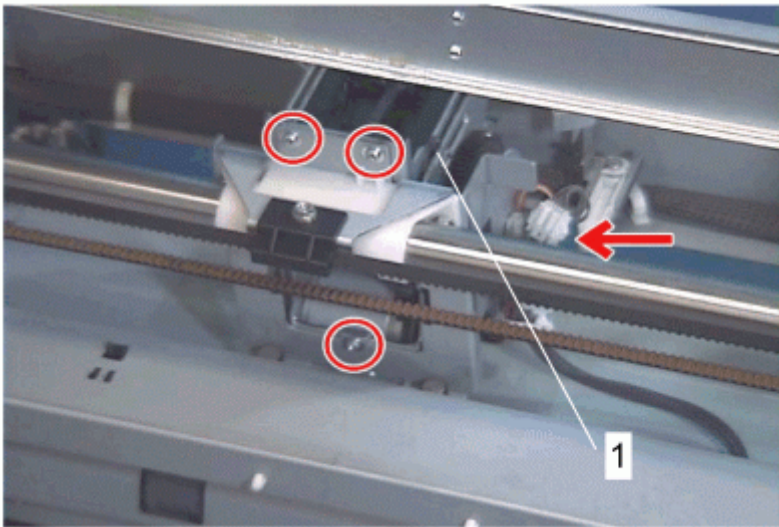
Reassembly

1. Mount the stapler drive unit [1].

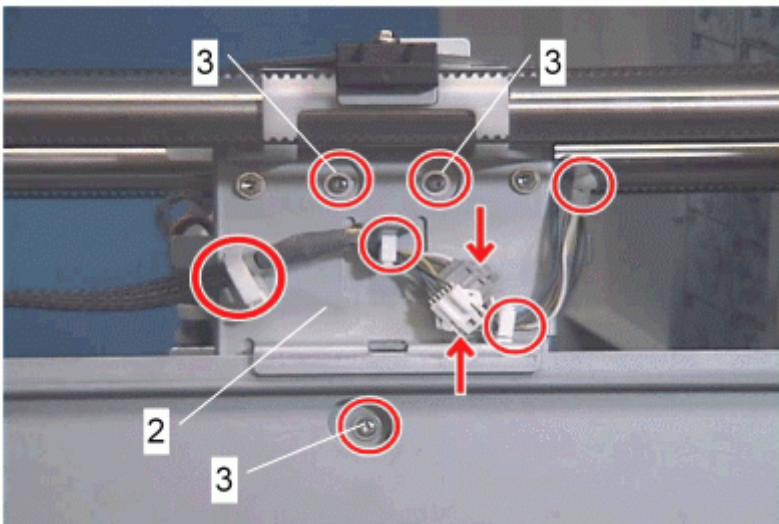

2. Mount the staple folder unit [2]. Do not tighten the screws [3] at this time.

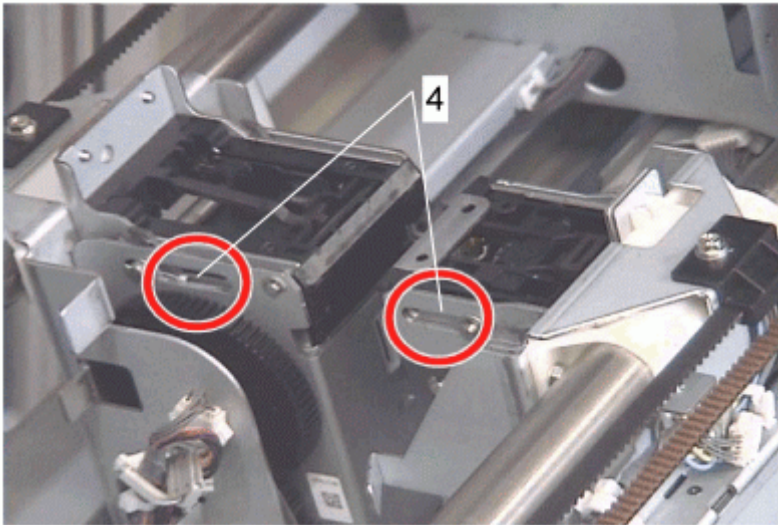

3. Set the special tool in the long hole [4] on both units.

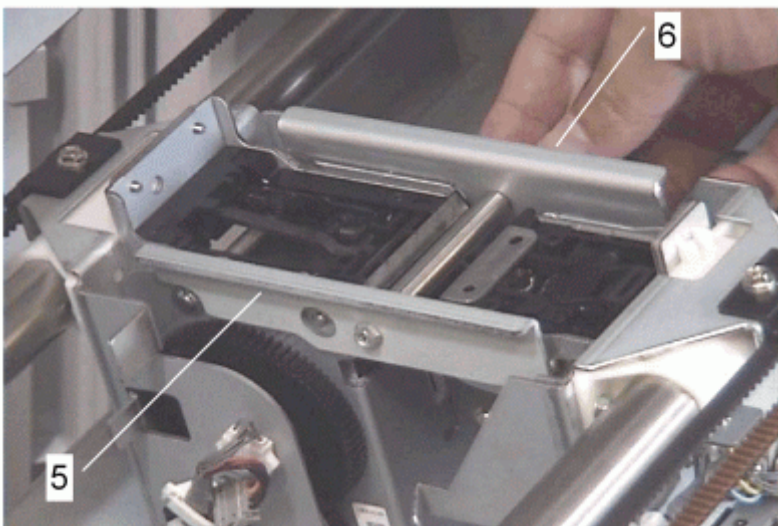

4. Secure the special tool [5] with the knob [6].

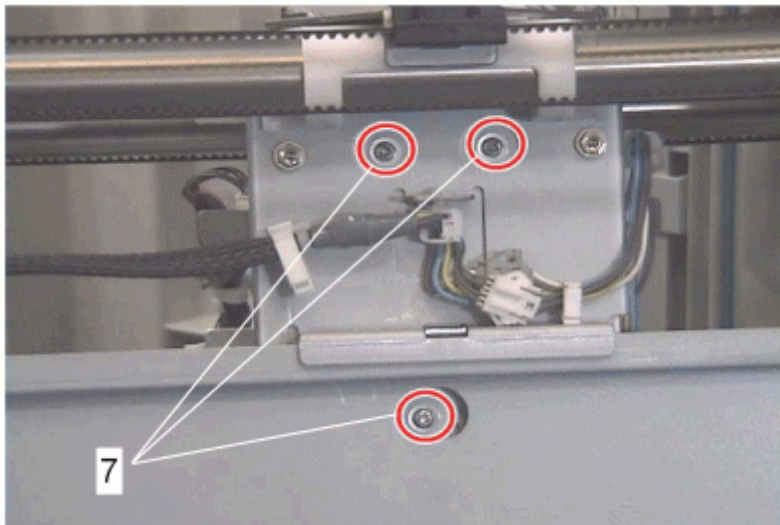

5. Tighten the screws [7] for the stapler folder unit.
6. Reassemble the machine.

Others

Main Board

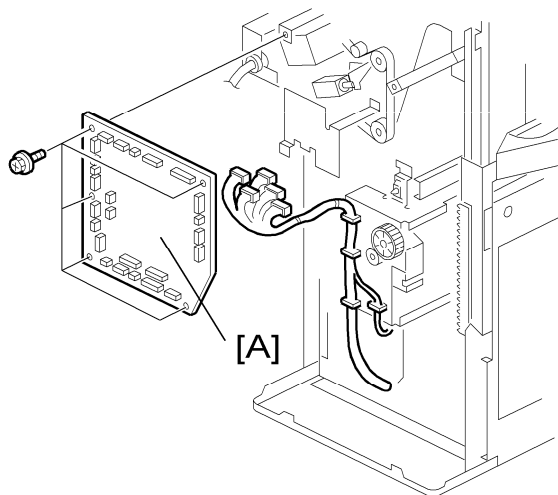

1. Remove the rear cover.
2. Remove the main board [A] (⚙ x 5).

DIP Switches

SW100: Adjust the staple position for booklet mode

No.	Function
1	ON: 0.3 mm
2	ON: 0.6 mm
3	ON: 1.2 mm
4	Direction OFF: Towards the trailing edge, ON: Towards the leading edge

SW101: Adjust the fold position

No.	Function
1	ON: 0.2 mm
2	ON: 0.4 mm
3	ON: 0.8 mm
4	Direction OFF: Towards the trailing edge, ON: Towards the leading edge

SW102: Move the tray position

No.	Function
1	OFF → ON → OFF Turn the switch from off to on, then turn it to off again. Then, the tray moves down to the shipping position
2	Not used

↓ Note

- After you change any of these dip switch settings, open and close the finisher cover to activate the new setting. It is not necessary to turn the main power off/on.

2. Detailed Section Descriptions

Component Layout

Mechanical Component Layout

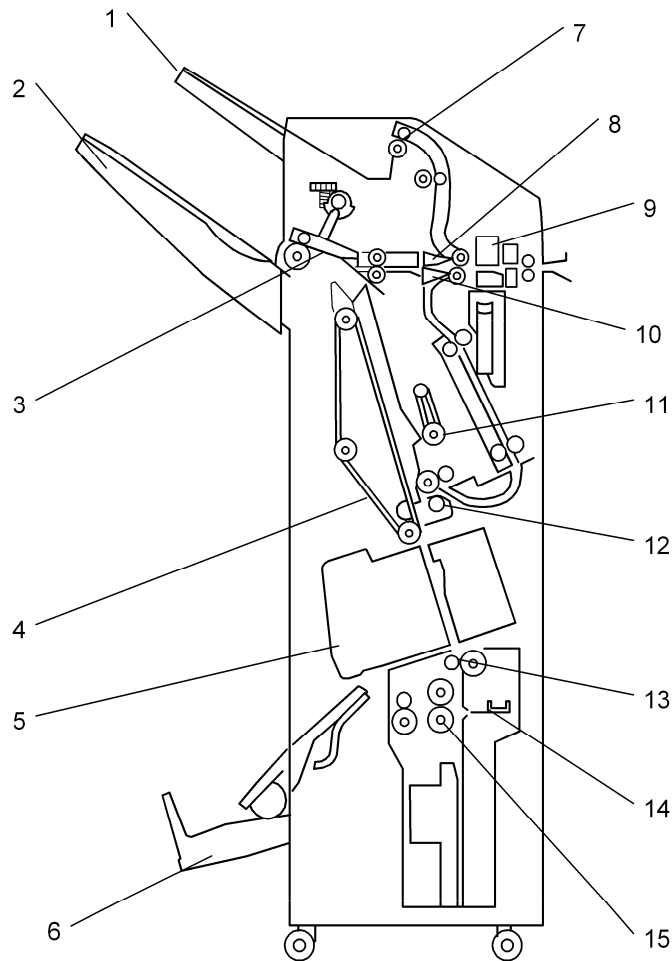

- | | |
|-----------------------------|-------------------------------|
| 1. Proof Tray | 9. Punch Unit |
| 2. Shift Tray | 10. Staple Tray Junction Gate |
| 3. Exit Guide Plate | 11. Positioning Roller |
| 4. Stack Feed Out Belt | 12. 1st Clamp Roller |
| 5. Staple Unit | 13. 2nd Clamp Roller |
| 6. Booklet Tray | 14. Folder Plate |
| 7. Proof Tray Exit Roller | 15. Folder Roller |
| 8. Proof Tray Junction Gate | |

Detailed Section Descriptions

Drive Layout

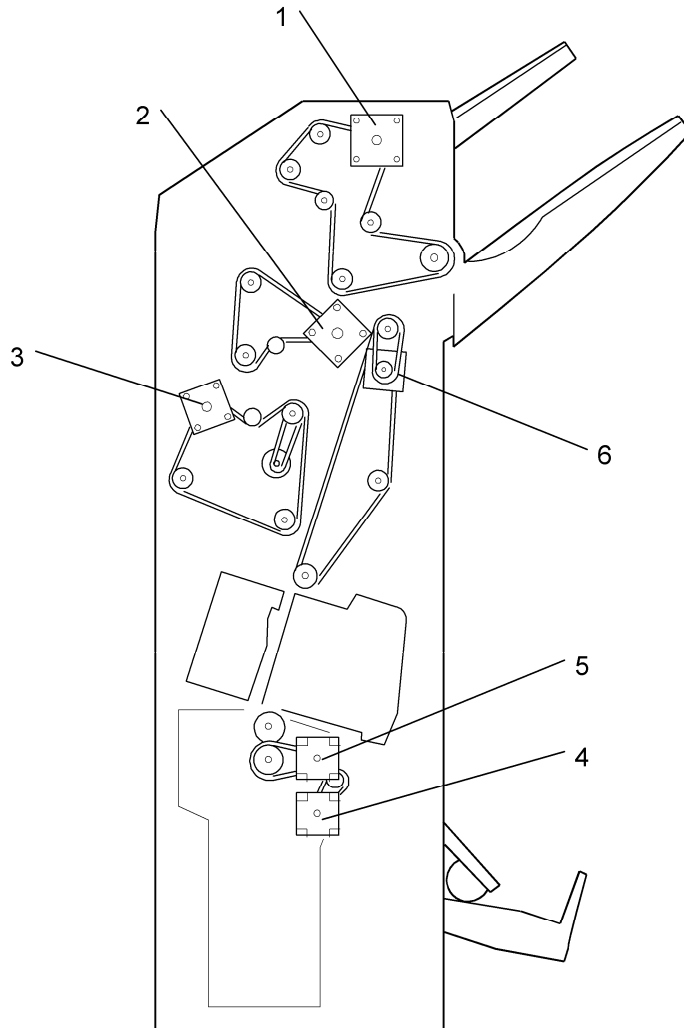

1. Upper Transport Motor
2. Entrance Motor
3. Lower Transport Motor
4. Fold Plate Motor
5. Fold Roller Motor
6. Stack Feed-out Motor

Detailed Section Descriptions

Electrical Component Layout

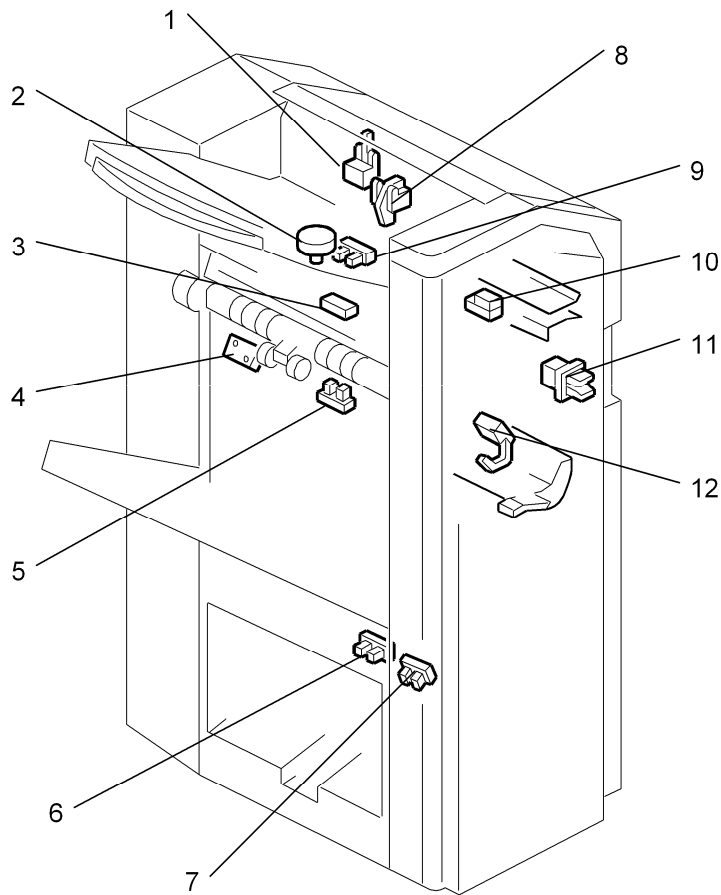

1. Proof Tray Exit Sensor

2. Exit Guide Plate Motor

3. Shift Tray Exit Sensor

4. Upper Limit Switch

5. Shift Tray Position Sensor

6. Rear Booklet Tray Full Sensor

7. Front Booklet Tray Full Sensor

8. Proof Tray Full Sensor

9. Exit Guide Plate HP Sensor

10. Entrance Sensor

11. Front Door Safety Switch

12. Staple Tray Exit Sensor

Detailed Section Descriptions

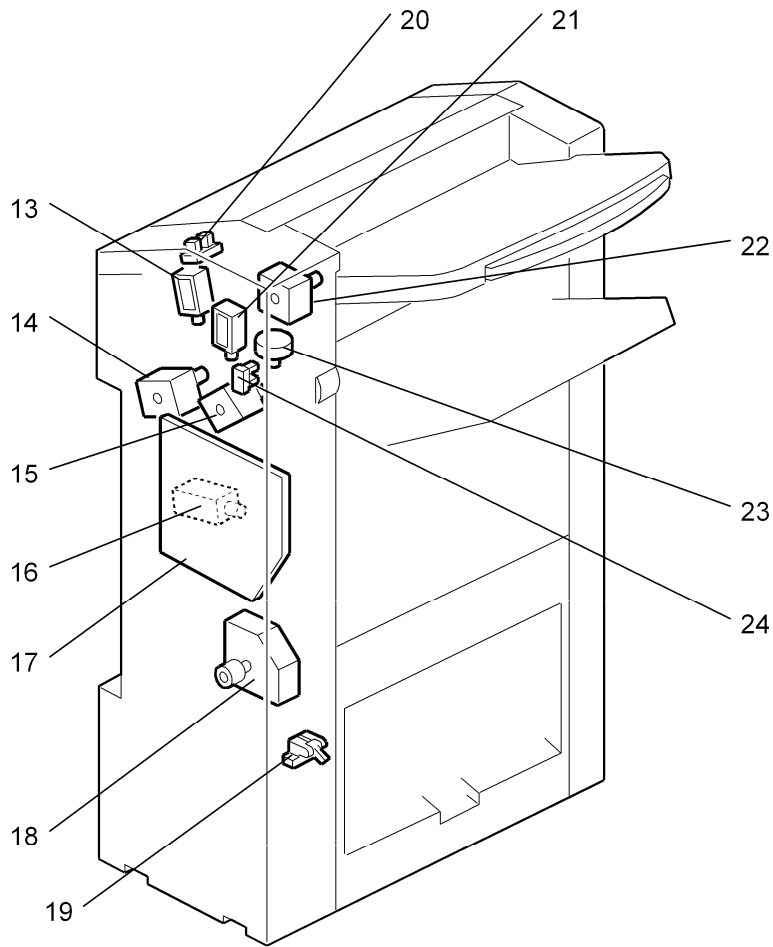

13. Proof Tray Gate Solenoid

14. Lower Transport Motor

15. Entrance Motor

16. Positioning Roller Solenoid

17. Main Board

18. Shift Tray Motor

19. Lower Limit Sensor

20. Upper Cover Sensor

21. Staple Tray Gate Solenoid

22. Upper Transport Motor

23. Shift Motor

24. Shift Motor HP Sensor

Detailed Section Descriptions

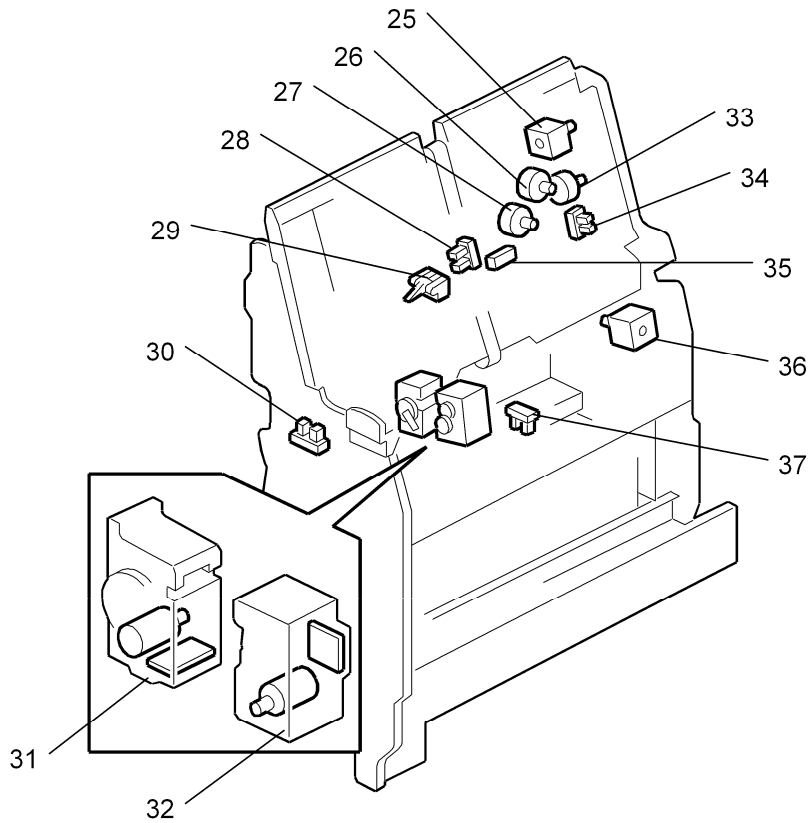

25. Stack Feed Out Motor

26. Jogger Motor

27. Upper Retraction Motor

28. Stopper S HP Sensor

29. Stack Feed Out HP Sensor

30. Staple Unit HP Sensor

31. Staple Driver Unit

32. Staple Folder Unit

33. Upper Clamp Roller Motor

34. Jogger HP Sensor

35. Staple Tray Paper Sensor

36. Stapler Unit Motor

37. Stapler Safety Sensor

Detailed Section Descriptions

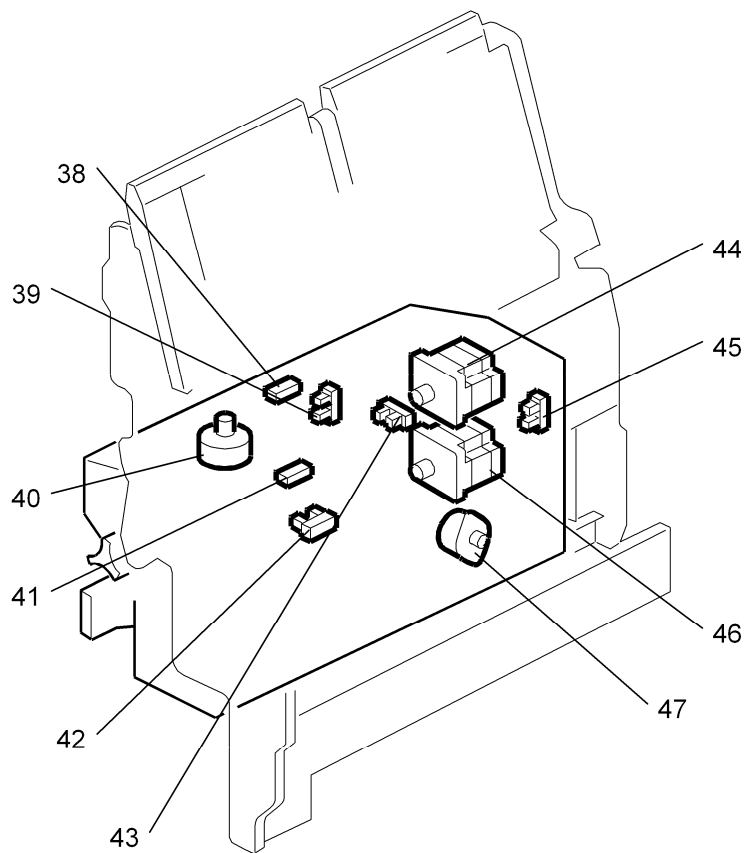

38. Fold Unit Exit Sensor

39. Lower Clamp Roller HP Sensor

40. Lower Retraction Motor

41. Fold Unit Entrance Sensor

42. Bottom Fence HP Sensor

43. Fold Cam HP Sensor

44. Fold Roller Motor

45. Fold Plate HP Sensor

46. Fold Plate Motor

47. Bottom Fence Lift Motor

Detailed Section Descriptions

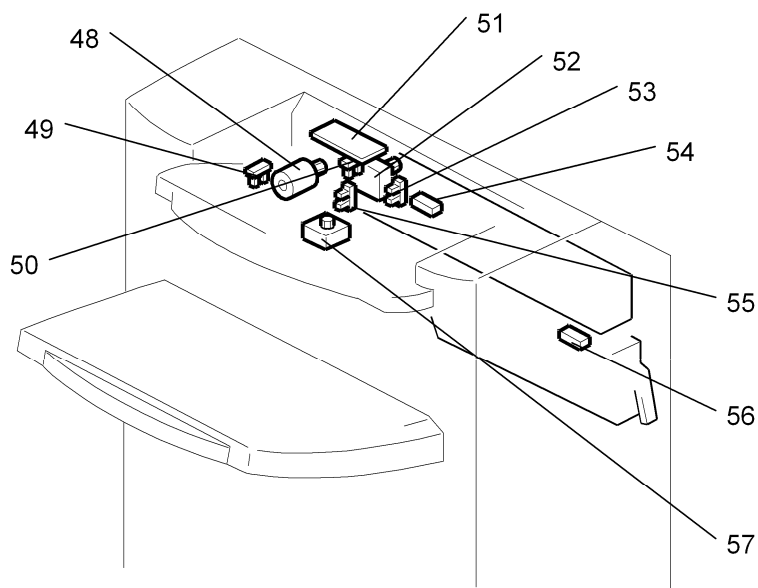

48. Punch Motor

49. Punch Encoder Sensor

50. Punch HP Sensor

51. Punch Board

52. Paper Position Sensor Slide Motor

53. Paper Position Slide HP Sensor

54. Paper Position Sensor

55. Punch Movement HP Sensor

56. Punch Hopper Full Sensor

57. Punch Movement Motor

Electrical Component Descriptions

Boards

Item	No.	Purpose
Main Board	17	Controls the finisher.
Punch Board	51	Controls the punch unit.

Sensors

Item	No.	Purpose
Proof Tray Exit Sensor	1	Detects paper when it is fed out to the proof tray.
Shift Tray Exit Sensor	3	Detects paper when it is fed out to the shift tray.
Shift Tray Position Sensor	5	Detects when the shift tray is at the correct height to receive paper.

Detailed Section Descriptions

Item	No.	Purpose
Rear Booklet Tray Full Sensor	6	One of two sensors that the machine uses to determine when the booklet tray is full.
Front Booklet Tray Full Sensor	7	One of two sensors that the machine uses to determine when the booklet tray is full.
Proof Tray Full Sensor	8	Detects when the proof tray is full.
Exit Guide Plate HP Sensor	9	Detects when the exit guide plate is at home position
Entrance Sensor	10	Detects when paper comes into the finisher
Staple Tray Exit Sensor	12	Detects paper leaving the bottom of the stapler
Lower Limit Sensor	19	Detects when the shift tray has moved to its lowest possible position (the shift tray is full).
Upper Cover Sensor	20	Detects when the upper cover is open
Shift Motor HP Sensor	24	Detects when the side-to-side motion of the shift roller is at home position
Stopper S HP Sensor	28	Detects when the 'stopper S' mechanism is at home position.
Stack Feed Out HP Sensor	29	Detects when the stack feed-out belt is at home position
Staple Unit HP Sensor	30	Detects when the side-to-side motion of the stapler unit is at home position
Jogger HP Sensor	34	Detects when the jogger unit is at home position
Staple Tray Paper Sensor	35	Detects when paper is fed into the stapler tray
Stapler Safety Sensor	37	Stops side-to-side movement of the stapler until stopper S and the stack feed-out pawl mechanisms are at home position, to prevent damage to the machine.
Fold Unit	38	1) Detects the folded edge of the stack as it feeds out from the nip of

Detailed Section Descriptions

Item	No.	Purpose
Exit Sensor		the fold rollers so the fold feeds back into the nip, 2) when the folded booklet finally emerges from the nip of the fold rollers, detects the leading and trailing edge of the booklet to make sure that it feeds out correctly.
Lower Clamp Roller HP Sensor	39	Detects when the lower clamp roller is at home position
Fold Unit Entrance Sensor	41	Detects 1) the leading edge of the stack during booklet stapling, and 2) also used to signal an alarm if a paper is detected at the entrance of the fold unit when the copier is turned on.
Bottom Fence HP Sensor	42	Detects when the bottom fence of the booklet folding mechanism is at home position
Fold Cam HP Sensor	43	Along with the fold plate HP sensor, this sensor controls the movement of the fold plate. The actuator mounted on the end of the roller that drives the folder plate forward and back makes three full rotations, i.e. the actuator passes the sensor gap twice and stops on the 3rd rotation and reverses. This accounts for the left and right movement of the fold plate.
Fold Plate HP Sensor	45	Along with the fold plate HP sensor this sensor controls the movement of the fold plate. The fold plate has arrived at the home position when the edge of the plate enters the gap of this sensor.
Punch Encoder Sensor	49	Controls the timing for activating the punches, to punch holes in the paper at the correct position.
Punch HP Sensor	50	Detects when the hole-punch firing mechanism is at home position
Paper Position Slide HP Sensor	53	Detects when the mechanism that measures the paper position in the punch unit is at home position
Paper Position Sensor	54	Detects the side edge of the paper, to tell the machine where to put the punch holes.
Punch Movement HP Sensor	55	Detects when the side-to-side motion of the punch unit is at home position.
Punch Hopper Full Sensor	56	Detects when the punch hopper is full. Also checks if the hopper is installed correctly.

Detailed Section Descriptions

Motors

Item	No.	Purpose
Exit Guide Plate Motor	2	Controls the exit guide plate mechanism.
Lower Transport Motor	14	Controls the positioning roller, and other rollers in the finisher (see 'Drive Layout' for details).
Entrance Motor	15	Controls the rollers at the entrance of the finisher.
Shift Tray Motor	18	Moves the shift tray up and down.
Upper Transport Motor	22	Controls the rollers that feed paper from the junction gate to the proof tray and to the shift tray (see 'Drive Layout' for details).
Shift Motor	23	Moves the shift tray from side to side.
Stack Feed Out Motor	25	Controls the stack feed-out belt
Jogger Motor	26	Controls the jogger in the stapler tray
Upper Retraction Motor	27	Controls the 'stopper S' mechanism. Also moves the upper clamp roller into contact and away from the stack of paper in the stapler tray.
Upper Clamp Roller Motor	33	Rotates the upper clamp roller.
Stapler Unit Motor	36	Moves the stapler from side to side.
Lower Retraction Motor	40	Drives a large cam that alternately clamps and unclamps the lower clamp roller, which is the idle roller of the clamp roller pair. When these rollers are clamped, they are part of the paper feed path and feed the stack toward the bottom fence of the fold unit. When the idle roller is retracted, the stacks falls a very short distance (3 mm) onto the fold unit bottom fence below. These rollers remain unclamped while the bottom fence positions the stack for folding and while the stack is folded by the fold rollers.
Fold Roller Motor	44	Controls the rollers that fold the paper.
Fold Plate Motor	46	Controls the plate that makes the fold in the paper.
Bottom	47	Raises the bottom fence and stapled stack to the correct fold position

Detailed Section Descriptions

Item	No.	Purpose
Fence Lift Motor		for the paper size.
Punch Motor	48	Punches the holes in the paper.
Paper Position Sensor Slide Motor	52	Controls side-to-side movement of the paper position sensor in the punch unit.
Punch Movement Motor	57	Moves the punch from side to side.

Solenoids

Item	No.	Purpose
Proof Tray Gate Solenoid	13	Controls the proof tray junction gate
Positioning Roller Solenoid	16	Controls the positioning roller.
Staple Tray Gate Solenoid	21	Controls the staple tray junction gate

Switches

Item	No.	Purpose
Upper Limit Switch	4	Detects when the shift tray is at the highest possible position, and cuts power to the shift tray motor.
Front Door Safety Switch	11	Cuts dc power when the front door is opened.

Others

Item	No.	Purpose
Staple Driver Unit	31	Pushes the staples into the paper.
Staple Folder Unit	32	Folds the ends of the staples after stapling

Junction Gates

Two junction gates control the path of paper.

Each junction gate is controlled by a solenoid.

Junction gate operation is summarized in the following table.

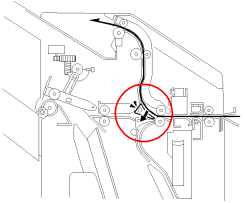
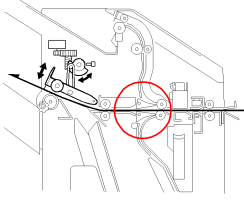
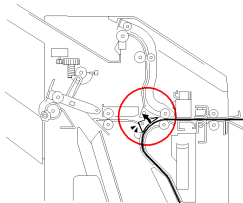
Mode	Proof	Shift	Staple
Paper Path			
Proof Tray Gate Solenoid	ON	OFF	OFF
Staple Tray Gate Solenoid	OFF	OFF	ON

Proof Tray

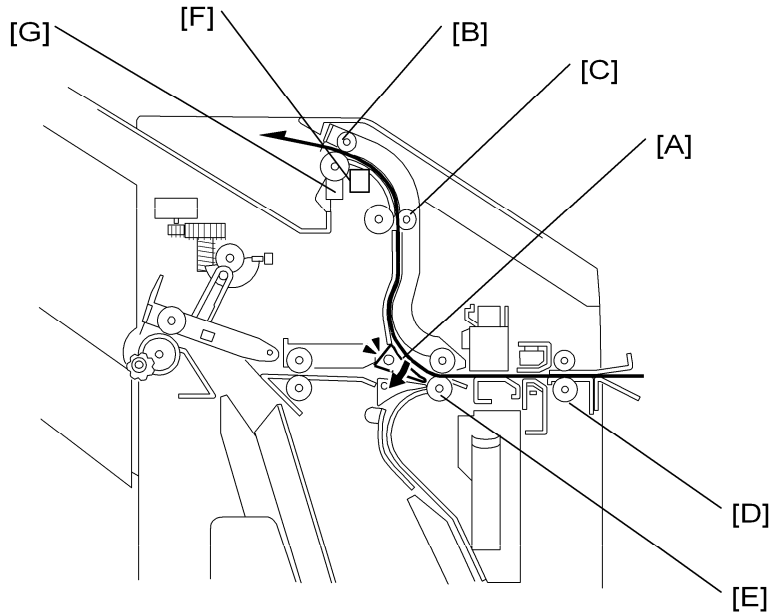

Proof Tray Junction Gate Control [A]: Proof Tray Gate Solenoid

Roller Drive:

- Proof Tray Exit Roller [B], Proof Tray Transport Roller [C]: Controlled by the Upper Transport Motor
- Entrance Roller [D], Transport Roller [E]: Controlled by the Entrance Motor

Jam Detection: Proof Tray Exit Sensor [F]

Tray Full Detection: Proof Tray Full Sensor [G]

Shift Tray

Up/Down Motion

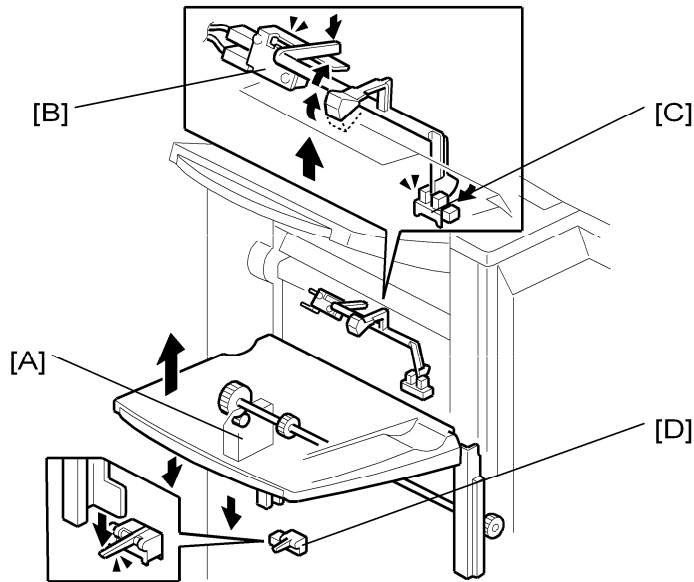

The shift tray motor [A] moves the tray up and down.

The upper limit switch [B] detects when the tray moves up too far, and cuts power to the shift tray motor.

The shift tray position sensor [C] checks when the tray (or the top of the stack) is at the correct height to receive paper.

- Shift Mode: This is checked every 5 sheets
- Staple Mode: This is checked every stack

The lower limit sensor [D] detects when the tray is full. At this point, the tray cannot move down any more.

Detailed Section Descriptions

Side-to-side Motion

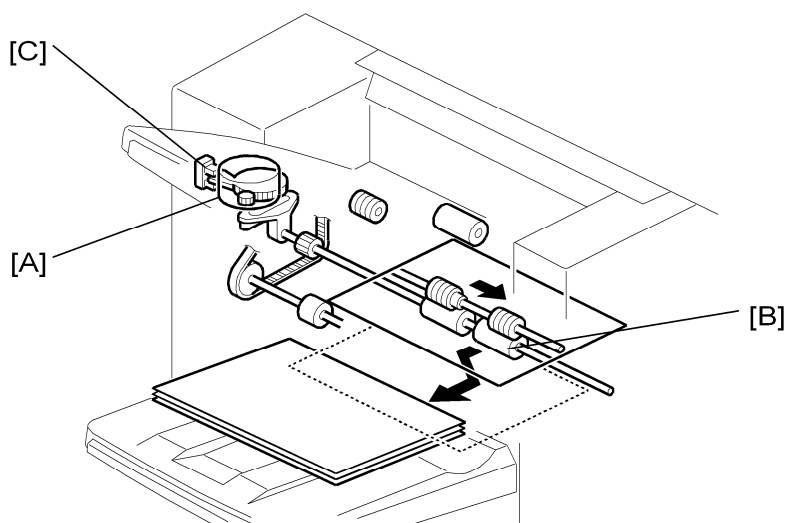

The shift motor [A] moves the shift roller [B] from side to side.

The shift motor HP sensor [C] detects when the mechanism is at home position.

The upper transport motor rotates the shift roller.

When shift mode is used, the shift motor turns on after each page is fed out. Then, for the next set, the shift motor turns the other way. In this way, the user can easily divide the sets.

Booklet Tray

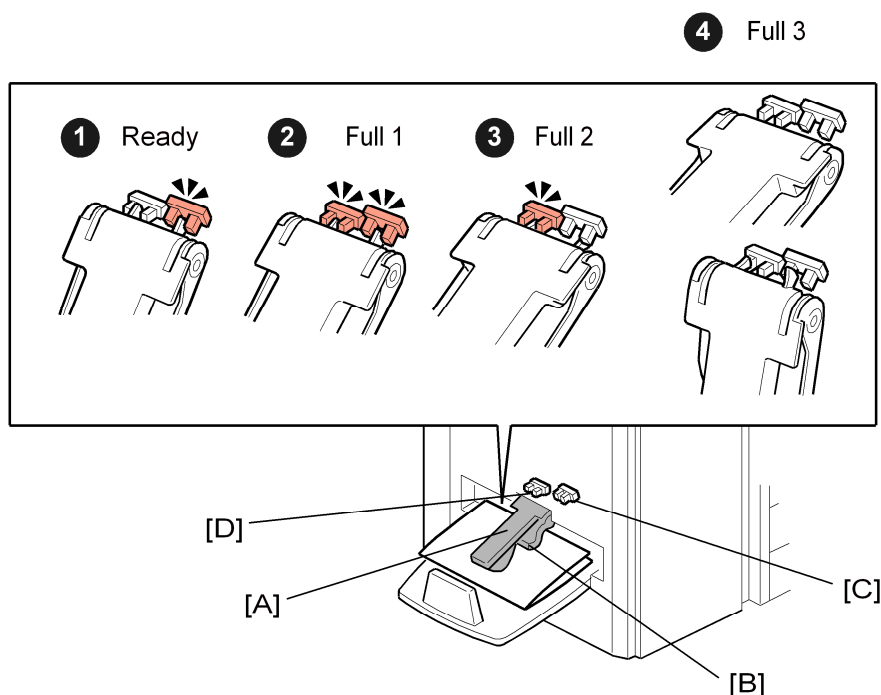

The sensor actuator arm [A] rests on the top of the stack of stapled booklets as they are output to the lower tray. A flap depressor [B] keeps the open ends of the booklets down. The front booklet tray full sensor [C] and rear booklet tray full sensor [D] detect when the tray is full of booklets.

Note

- The front booklet tray full sensor is mounted higher than the rear booklet tray full sensor.
- The booklet tray is stationary. When it becomes full, the stapling and folding job stops until booklets are removed from the tray.
- If the booklet tray is not installed (this is detected if the front and rear sensors remain OFF), the machine will not operate in the booklet staple and fold mode. When booklet mode is selected, the tray full message appears on the operation panel.

The combinations of the two actuators and two sensors when the actuator arm rises determines the number of booklets that the tray can hold before the job stops.

Tray full detection depends on the size of the paper and the number of sheets in one stapled and folded booklet.

The condition detected by the machine (1 Ready, 2 Full 1, 3 Full 2, 4 Full 3; see the illustration above) depends on the states of the sensors, as shown in the table below.

Detailed Section Descriptions

Condition	Front Sensor	Rear Sensor
Ready	ON	OFF
Full 1	ON	ON
Full 2	OFF	ON
Full 3 (or booklet tray not installed)	OFF	OFF

In the tables below:

- "Sht" denotes "sheets in a stack".
- "Cnt" denotes "Count" (see below for an explanation).

After a booklet is feed out, the fold roller motor stops the exit roller. The machine then monitors the tray full sensors every feed-out of a paper stack. The machine checks a certain condition, based on the size of the paper and the number of sheets in the booklet.

Two examples are shown below the table. Tell the operators that the number of sheets that the lower tray can hold will vary greatly.

- Lower Tray Full Condition Tables -

A3 (DLT)

Sheet	1	2	3	4	5	6	7	8	9	10
Full 1	15 Cnt	-	-	-	-	-	-	-	-	-
Full 2	-	3 Cnt	11 Cnt	-	-	-	-	-	-	-
Full 3	-	-	-	16 Cnt	12 Cnt	2 Cnt	3 Cnt	5 Cnt	6 Cnt	7 Cnt

A4 (LT)

Sheet	1	2	3	4	5	6	7	8	9	10
Full 1	15 Cnt	-	-	-	-	-	-	-	-	-
Full 2	-	8 Cnt	16 Cnt	19 Cnt	5 Cnt	2 Cnt	2 Cnt	2 Cnt	3 Cnt	4 Cnt
Full 3	-	-	-	-	-	-	-	-	-	-

Detailed Section Descriptions

- Examples -

After the copier makes a booklet with 1 sheet of A3/DLT paper, the machine checks every feed-out of a paper stack for the 'Full 1' condition. If the Full 1 condition occurs 15 times ('**15 Cnt**' in the table above), the machine detects that the tray is full.

After the copier makes a booklet with 5 sheets of A4/LT paper, the machine checks every feed-out of a paper stack for the 'Full 2' condition. If the Full 3 condition occurs 5 times ('**5 Cnt**' in the table above), the machine detects that the tray is full.

Jogger Unit

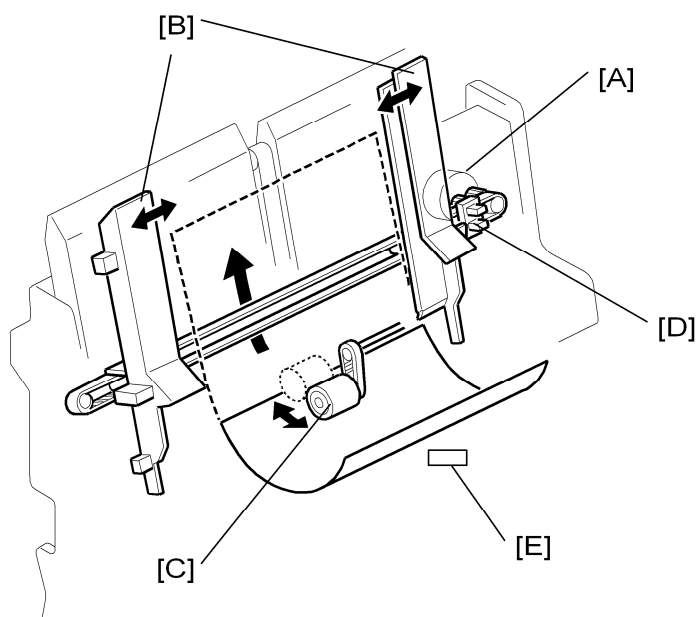

The jogger is used in corner-staple mode and in booklet mode.

For each sheet of paper when it arrives in the staple tray, the following is done.

- The jogger motor [A] drives the jogger fences [B].
- The positioning roller solenoid moves the positioning roller [C] onto the top of the sheet. Then the lower transport motor turns on and the positioning roller rotates to push the sheet of paper against the stopper (there are two stoppers: stopper L or stopper S the one that is used depends on the paper size, as we shall see later.)

The jogger HP sensor [D] detects when the jogger fences are at home position (away from the stack).

The staple tray exit sensor [E] detects if a jam occurs when the machine feeds the stack out at the bottom of the jogger tray.

Exit Guide Plate, Paper Feed Out

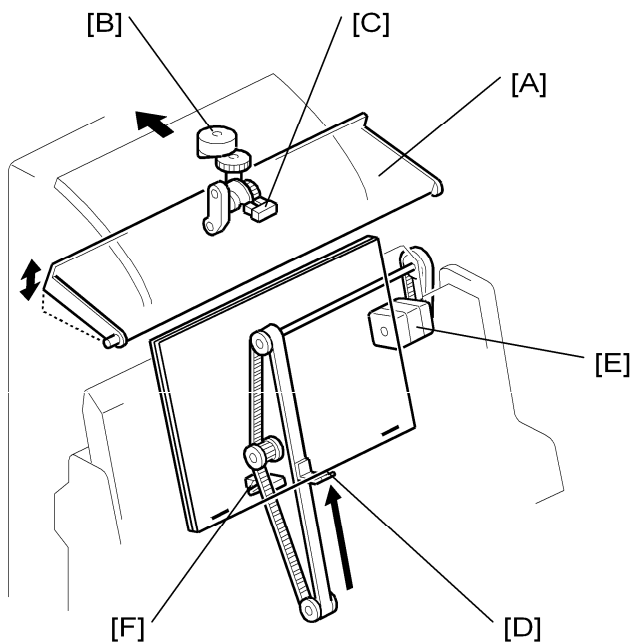

The exit guide plate [A] opens when a stapled stack is fed out.

Also it opens every time a sheet is fed to the staple tray, to prevent the paper running into the exit roller during stacking.

The exit guide plate motor [B] drives the exit guide plate. The exit guide plate HP sensor [C] detects when the guide plate is at home position.

The stack feed-out belt feeds out stapled stacks. The pawl [D] on the belt moves the stack out to the exit.

The stack feed-out motor [E] drives the belt. The stack feed-out HP sensor [F] detects when the belt is at home position.

Stapler Unit Movement

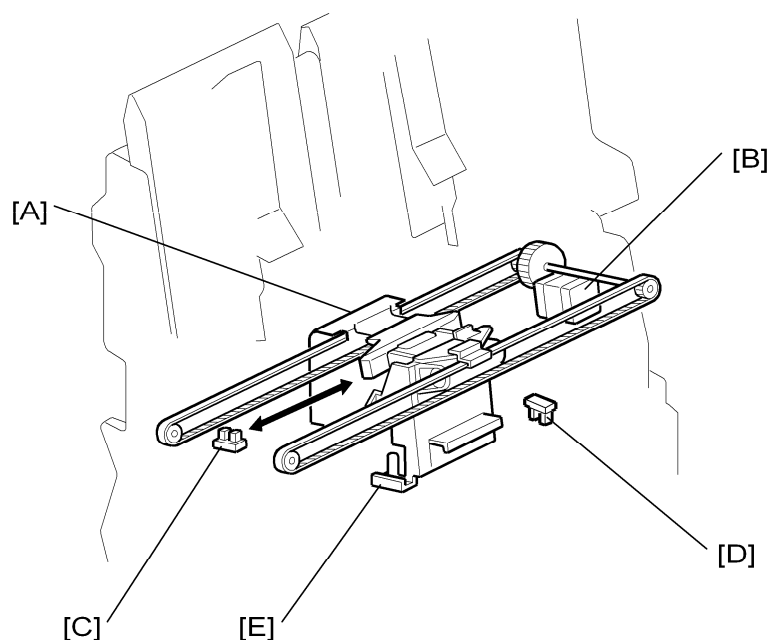

The machine has only one stapler [A]. It does stapling for booklets and for corner stapling. The stapler unit motor [B] moves the stapler from side to side. The stapler unit HP sensor [C] detects when the stapler unit is at home position.

In corner staple mode, at the start of the job, the stapler moves to the position where the stapler will be inserted.

In booklet mode, at the start of a job, the stapler moves to a starting position that depends on the paper size, as follows:

- B4 or shorter than B4: Rear side staple position
- Longer Than B4: Center position. When the stapler is at the center position, bracket [E] releases 'stopper L', which catches the bottom edge of the paper for booklet stapling with longer paper sizes. This will be described in a later section.

If the stapler safety sensor [D] detects the stapler unit at its initialization, the stapler unit stops moving until the stack feed out belt pawl and stopper S are at home position. If the stapler unit does not stop, it could collide with the pawl and/or the stopper.

Stacking for Booklet Stapling

Overview

There are two stoppers near the stapler unit. These stoppers hold the stack of paper in the correct position during stacking.

The stoppers are called 'stopper S' and 'stopper L'. Stopper S is used for B4 paper, or shorter than B4. Stopper L is used for paper that is longer than B4.

↓ Note

- In corner stapling mode, the pawl on the stack feed-out belt holds the stack of paper. For booklet stapling, this pawl stays at home position, which is on the rear side, so it does not interfere with booklet stapling.

B4 or Shorter Than B4

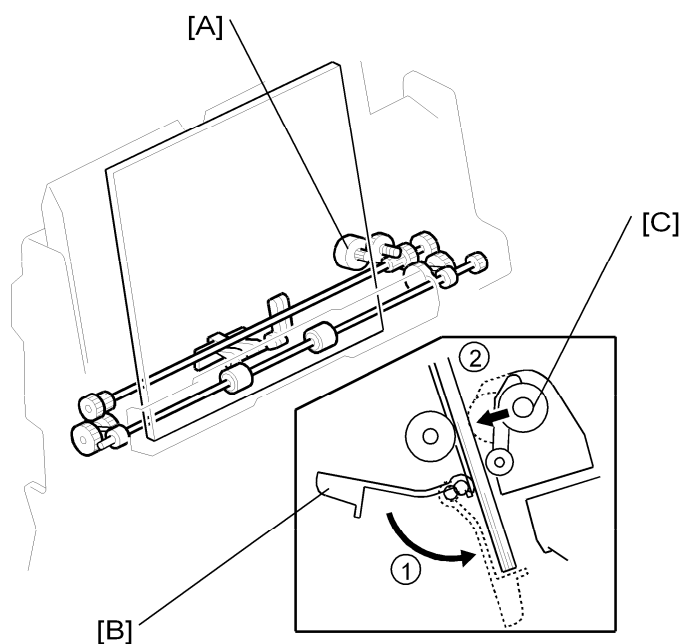

At the start of the set, the upper retraction motor [A] turns on, and stopper S [B] moves down into position to catch the paper ①. The upper retraction motor also moves the upper clamp roller [C] into contact with the stack ②.

Detailed Section Descriptions

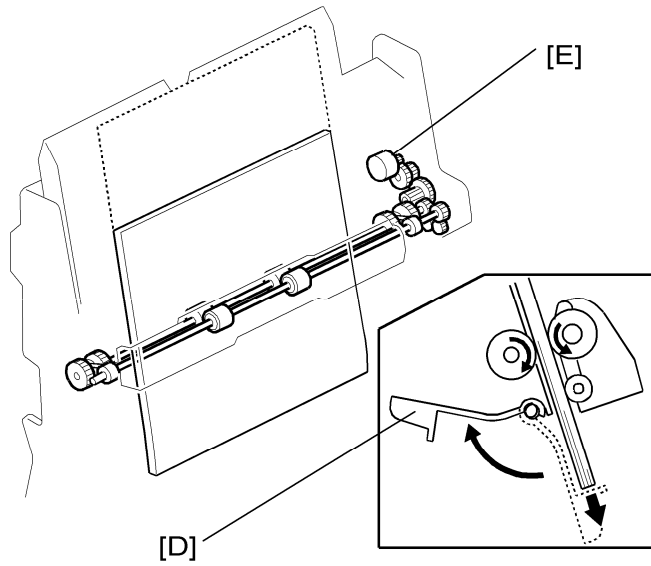

When the stack is complete, stopper S moves away [D], and the machine feeds the stack to the correct position for stapling. To do this, the upper clamp roller motor [E] rotates the upper clamp roller.

Longer Than B4

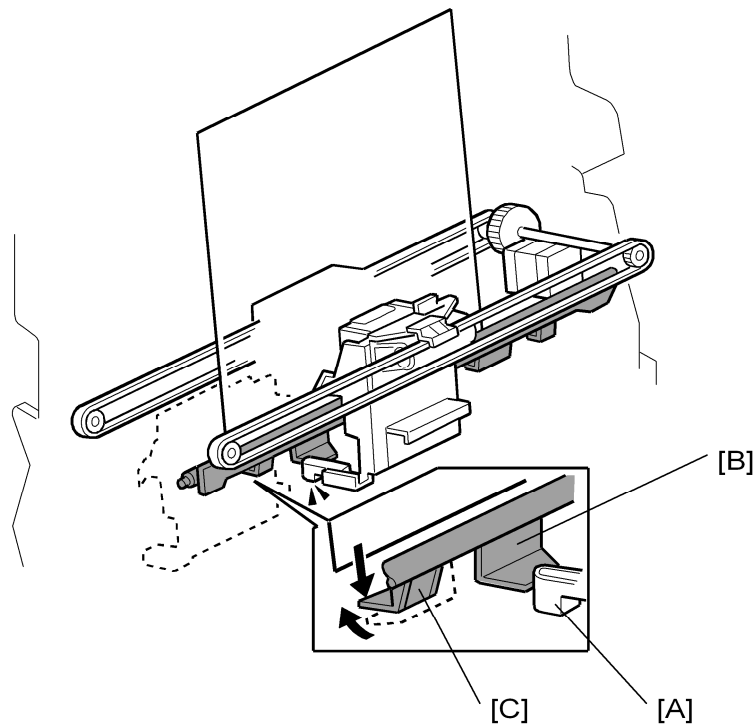

At the start of the set, the stapler moves to the center position. At this position, a bracket [A] on the stapler unit pushes stopper L [B]. The pawl [C] on the stopper L assembly then

Detailed Section Descriptions

moves into position to catch the paper. The upper clamp roller holds the stack (see the previous section).

When the stack is complete, the stapler moves to the rear-side position, and stopper L moves away. The machine feeds the stack to the correct position for stapling.

Moving the Stack to the Folding Position

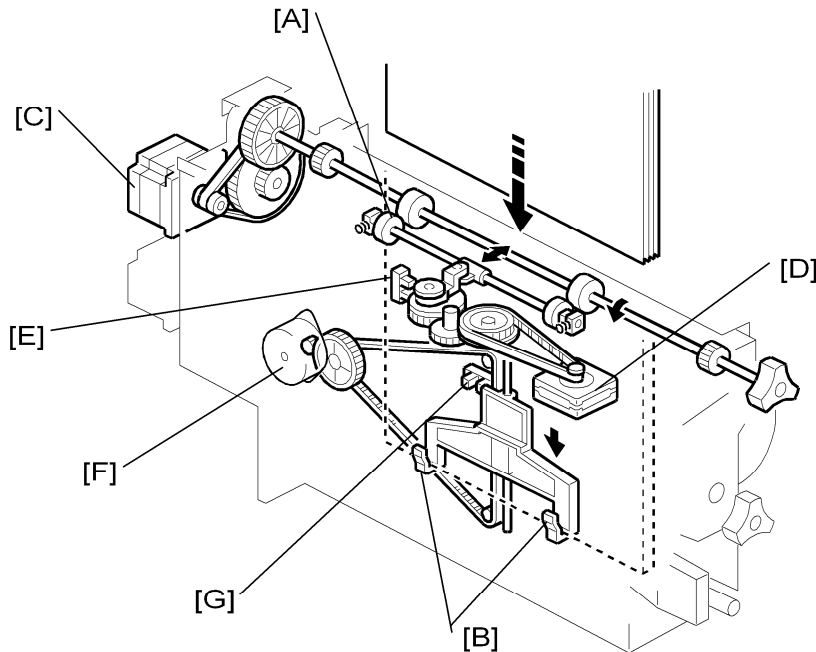

First, the upper clamp roller feeds the stack down after the stack has been stapled. When the lower clamp roller [A] catches the stack, the upper clamp roller stops, and the lower clamp roller feeds the stack down.

The lower clamp roller is released just before the leading edge of the stack reaches the bottom fence [B] (this fence consists of two pawls that catch the paper). The bottom fence moves the stack to the folding position

The fold roller motor [C] turns the lower clamp roller.

The lower retracting motor [D] moves the lower clamp roller against and away from the stack. The lower clamp roller HP sensor [E] detects when the lower clamp roller is moved to the home position.

The bottom fence lift motor [F] moves the bottom fence up and down. The bottom fence HP sensor [G] detects when the bottom fence is at home position.

Folder

Overview

The fold plate pushes the stack into the nip between the fold rollers. The fold rollers feed out the stack, then reverse to feed it back in again. Then, the fold rollers feed the stack out of the folder, to the booklet tray.

Fold Plate

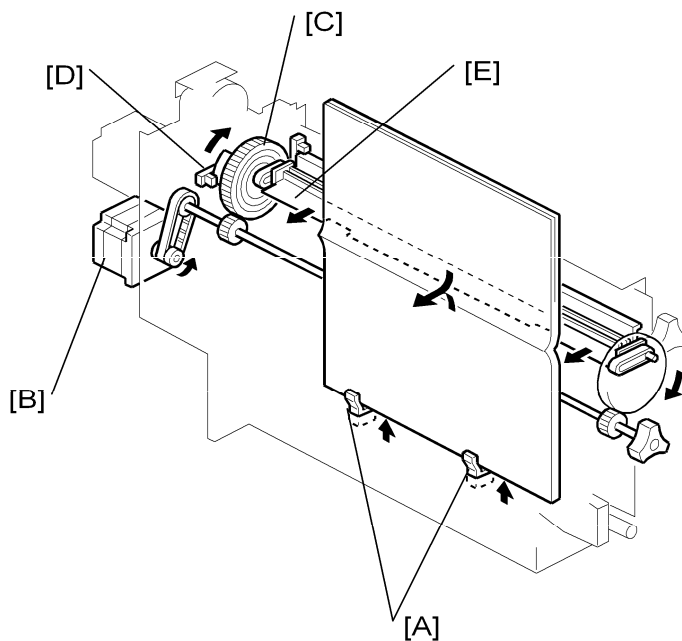

[A]: Bottom Fence Stack Stoppers. Catches the stack after it is released by the clamp rollers.

[B]: Fold Plate Motor. Drives the timing belt and gears that move the fold plate.

[C]: Fold Plate Cam. Controls the movement of the fold plate to the left (into the nip of the fold rollers) and right (toward the fold plate home position).

[D]: Fold Plate HP Sensor. Controls operation of the fold plate motor.

[E]: Fold Plate. Moves left and pushes the stack into the nip of the fold rollers and then moves right to retract.

Fold Rollers

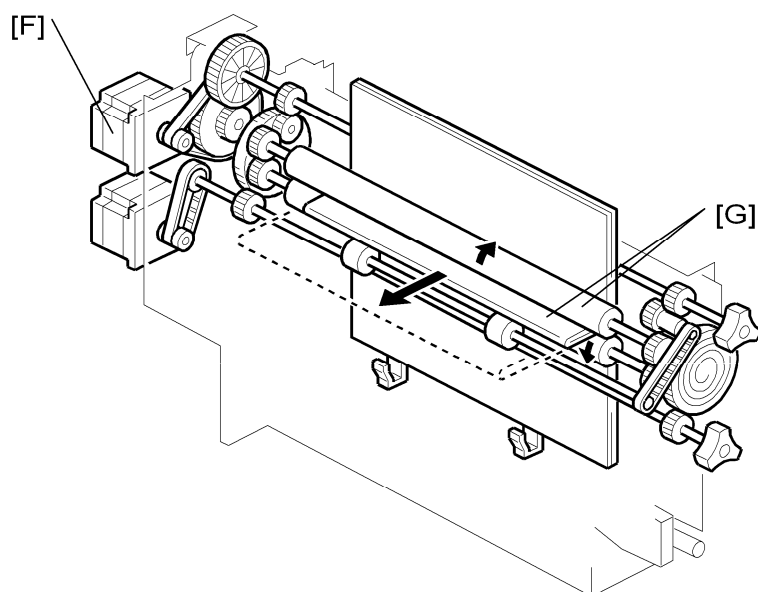

[F]: Fold Roller Motor. Drives forward to feed out the stack at the fold, and then drives forward again to feed out the folded stack.

 Note

- This cycle can be repeated by changing the setting of SP6136.

[G]: Fold Rollers. Driven by the fold roller motor, this roller pair feeds out the stack at its fold, reverses to feed in the stack to, and then feeds forward again (assisted by the fold unit exit rollers – not shown) to feed out the stack to the lower tray.

Punch Unit

Overview of Operation

Skew Correction Before Punching

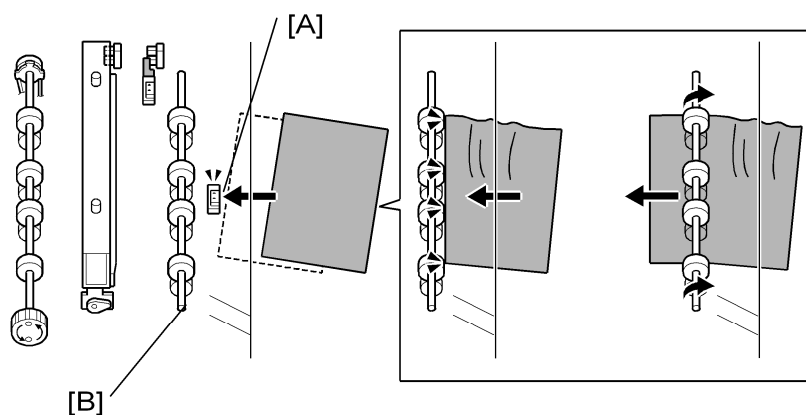

The finisher entrance roller corrects for paper skew and then the punch unit moves across to punch the holes at the correct position. Each sheet is punched one at a time.

Paper feeds out of the copier. The finisher entrance sensor [A] detects the leading edge of the sheet.

The finisher entrance roller [B] stops rotating briefly while the copier exit rollers continue to rotate. This buckles the paper against the finisher entrance roller to correct skew. The finisher entrance roller starts to rotate again and feeds the sheet into the finisher.

These SP codes adjust the skew operation in the punch unit:

- SP6130. This SP corrects the punch hole alignment. To do this, it corrects the skew of each sheet by adjusting the amount of time the finisher entrance roller remains off while the exit roller of the machine remains on. For more, see Section "5. Service Tables".
- SP6131. This SP determines whether the finisher entrance roller stops to correct skew when paper enters the finisher. You can use this SP to disable the skew correction. For more, see Section "5. Service Tables".

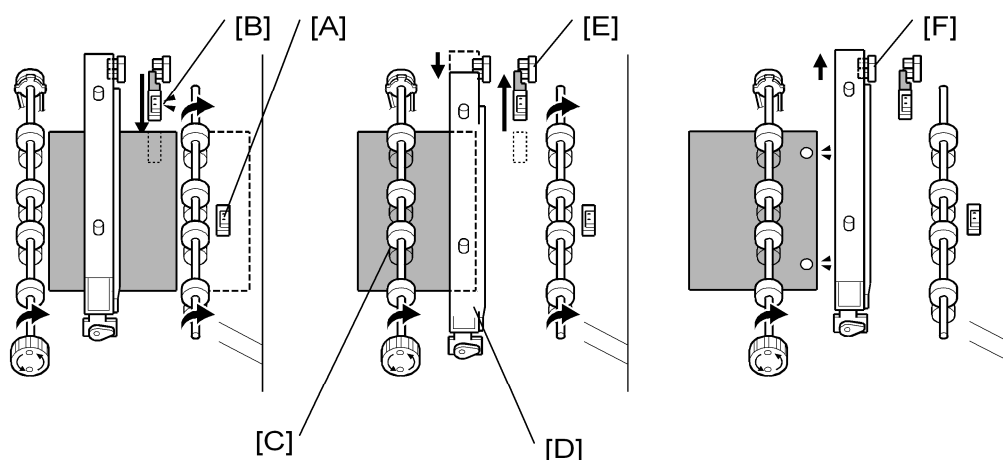

These operations (skew correction before punching, and punch unit position correction) increase the accuracy of the punch alignment.

1

The trailing edge of the sheet passes the finisher entrance sensor [A].

The paper position slide unit moves the paper position sensor [B] forward to the edge of the paper.

The paper position sensor detects the position of the paper edge and sends this information to the punch unit board. The machine uses the detected position of the paper edge to calculate the correct position for punching.

The upper transport motor switches on and rotates the feed rollers [C] the prescribed distance to put the paper under the punch unit [D].

2

Using the result of the position calculation, the punch unit control board moves the punch unit [D] to the adjusted punch position.

The paper position slide unit and its paper sensor, move back to the paper position slide home position sensor [E], and the punch unit fires the punches to make the holes.

3

The feed rollers feed the punched paper out of the punch unit and into the paper path. The punch unit moves back to home position (detected by the home position sensor [F]).

Detailed Section Descriptions

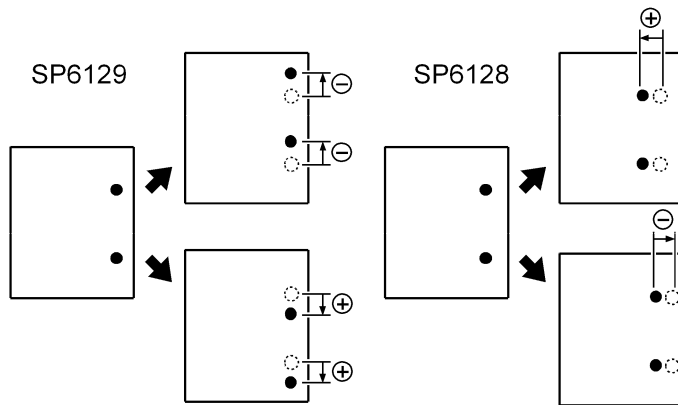

These SP codes adjust the punch hole alignment:

- SP6128 Adjusts the punch positions in the direction of paper feed.
- SP6129 Adjusts the punch position perpendicular to the direction of feed.

For more, see Section "5. Service Tables".

Paper Position Detection

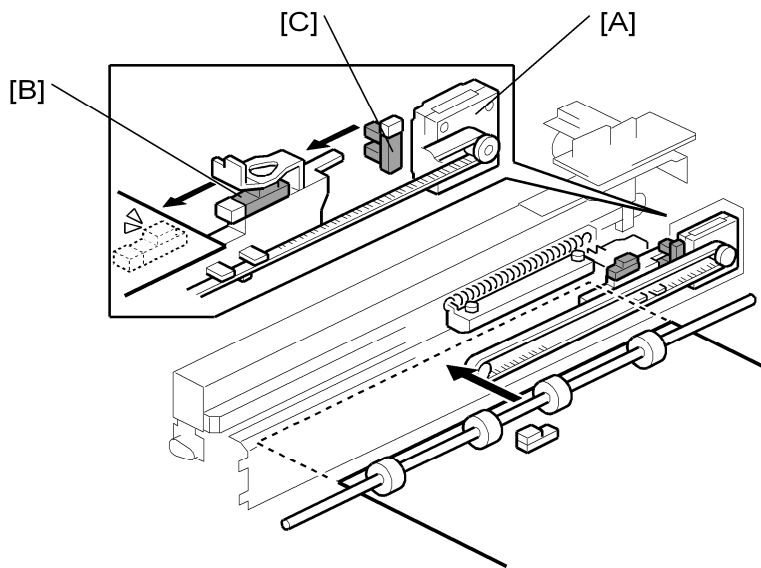

The paper position sensor slide motor [A] extends and retracts the paper position slide that holds the paper position sensor [B].

The paper position sensor detects the position of the paper edge. The detected position of the paper is used to move the punch unit across to the correct position for punching.

When the paper position slide is retracted, the paper position slide HP sensor [C] detects when the slider is at home position and stops paper position slide motor.

Detailed Section Descriptions

Punch Unit Movement

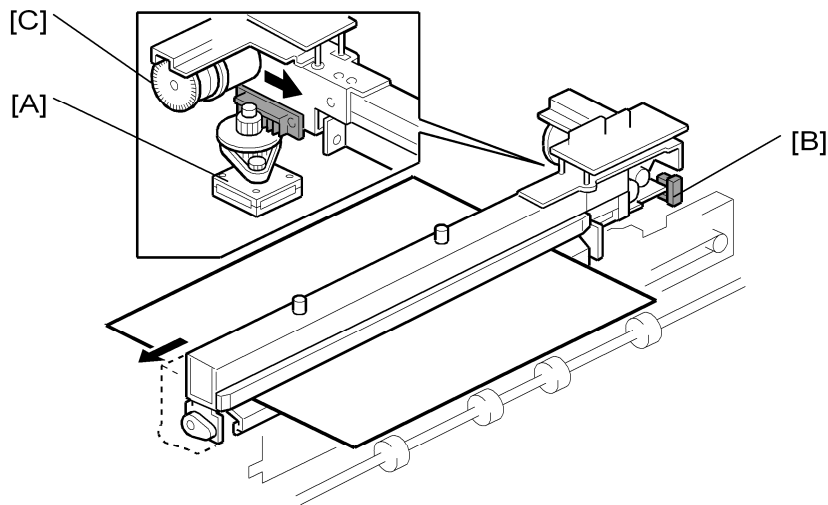

The punch movement motor [A] extends and retracts the punch unit to put it at the correct position for punching.

The punch movement HP sensor [B] detects the position when it retracts, switches off the punch movement motor, and stops the punch unit at its home position.

The punch drive motor [C] fires the punches that punch holes in the paper below.

Punch Selection and Firing

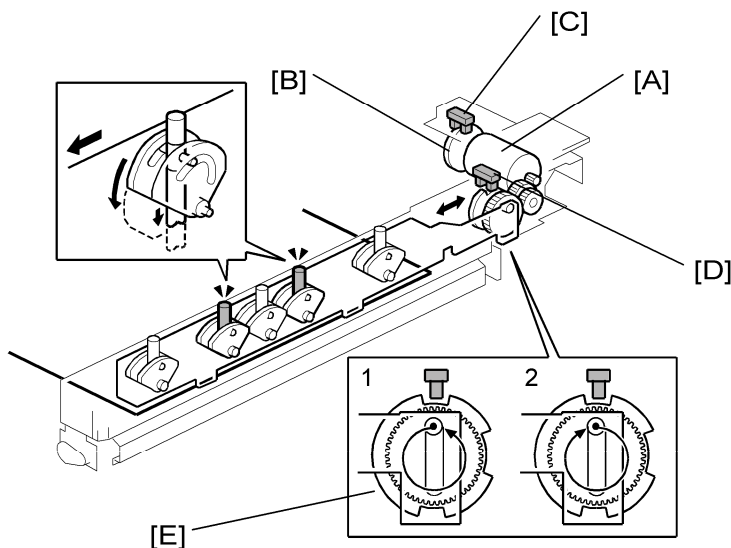

The punch drive motor [A] turns the small, notched encoder wheel [B] through the gap in the punch encoder sensor [C]. The sensor output is used to control the punch timing.

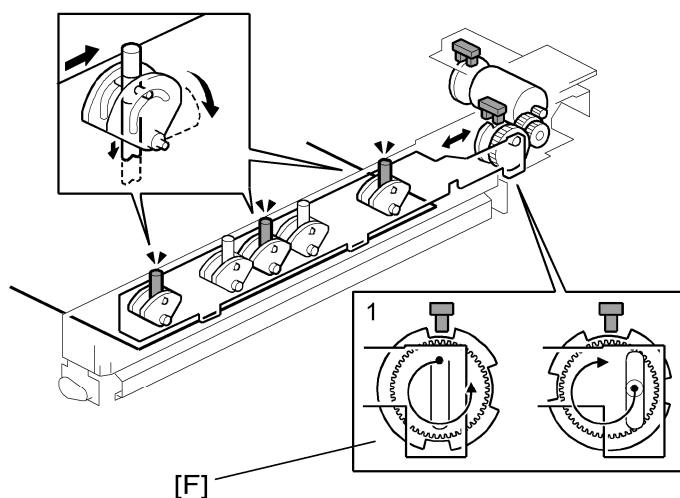

The timing for 2-hole punching [E] is different from 3-hole punching [F].

When the punch unit is at the punching position, the punch motor turns until the encoder detects the starting position for 2-hole or 3-hole punching.

- This is the '1' position in the diagrams (the first diagram is for 2-hole punching, and the second diagram is for 3-hole punching).

Then, the punch drive motor turns counter-clockwise to the '2' position. This movement punches the holes in the paper.

Then, the punch drive motor turns clockwise to the '1' position, to be ready for the next sheet of paper.

Detailed Section Descriptions

Punch Hopper Mechanism

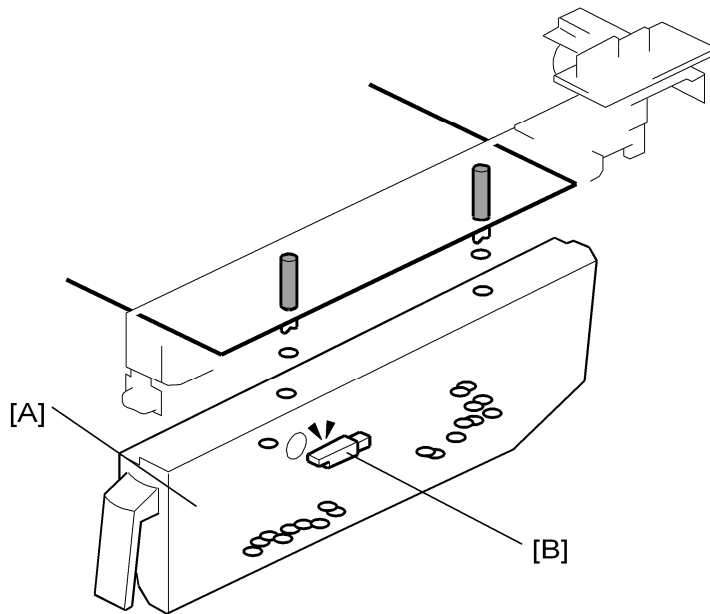

The punchouts fall from the punch unit into the punch hopper [A].

The punch hopper full sensor [B] does the following:

- Signals that the hopper is full when it detects the top of the stack of punchouts that have collected in the hopper.
- Detects when the punch hopper is set properly.