

SYMBOL TABLE			
[]	Voltage	▲	Active High
A	Analog Signal	◄	Active Low
→	Signal Direction		

500-Sheet Finisher (D372) POINT TO POINT DIAGRAM

D372 ELECTRICAL COMPONENT LAYOUT

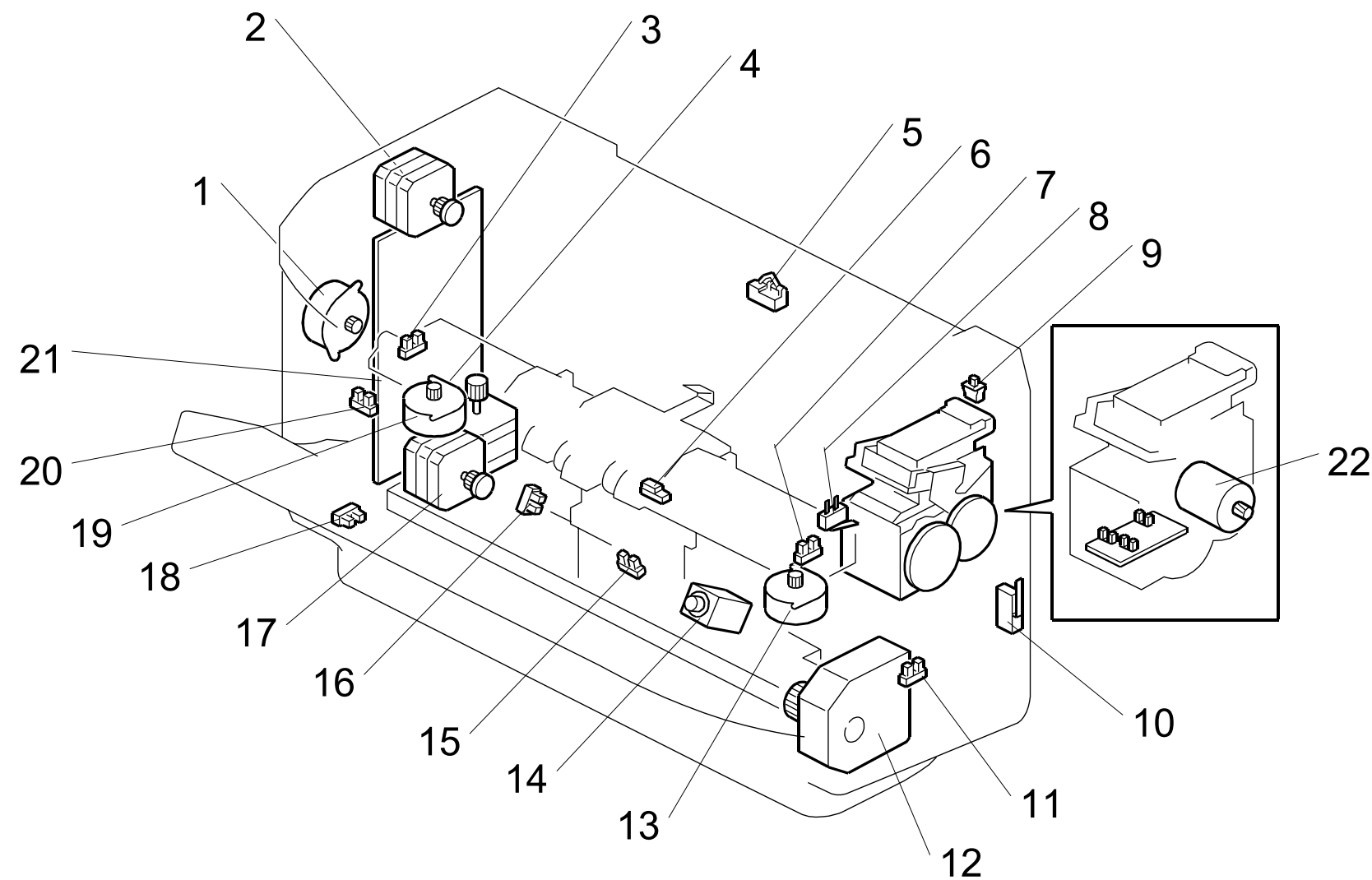

Symbol	Name	Index No.	P to P
Motors			
M1	Transport Motor	2	A8
M2	Positioning Roller Motor	1	A8
M3	Stapler Movement Motor	4	B8
M4	Tray Lift Motor	12	C8
M5	Rear Fence Motor	19	C8
M6	Front Fence Motor	13	D8
M7	Feed-Out Belt Motor	17	D8
M8	Stapler Motor	22	E8
Sensors			
S1	Front Fence HP Sensor	7	C2
S2	Stapler Tray Paper	6	C2
S3	Feed-Out Belt HP	15	C2
S4	Rear Fence HP Sensor	3	C2
S5	Paper Height Sensor	16	D2
S6	Positioning Roller HP Sensor	20	D2
S7	Output Tray Full Sensor	18	D2
S8	Stapler HP Sensor	11	D2
S9	Entrance Sensor	5	E2

Symbol	Name	Index No.	P to P
Switches			
SW1	Stapler Door Switch	10	E2
SW2	Tray Upper Limit Switch	8	E2
SW3	Top Cover Switch	9	E2
Solenoid			
SOL1	Stack Depressor	14	C8
PCB			
PCB1	Main Board	21	F5